

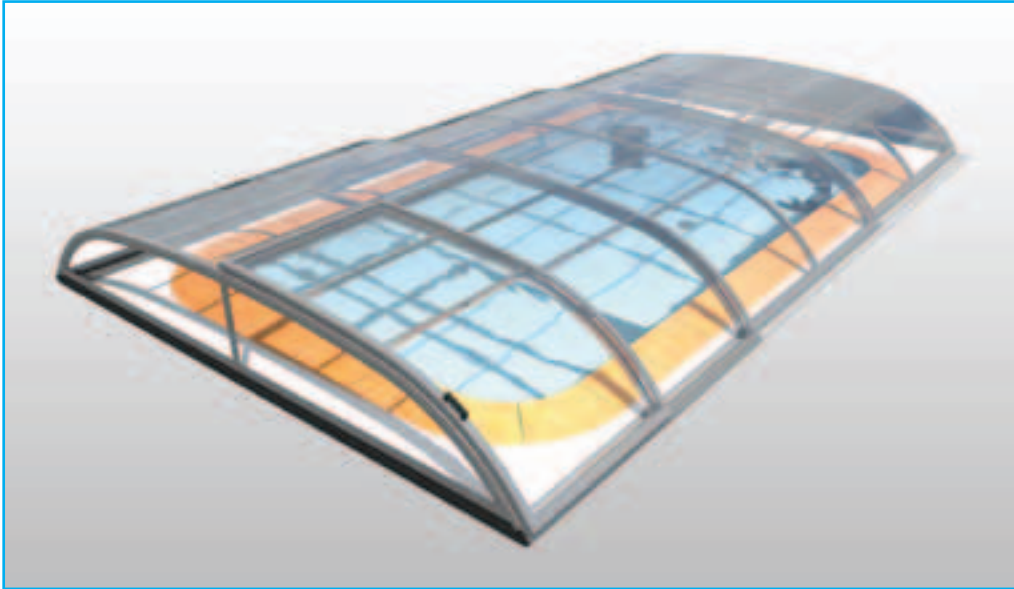

A Q U A C O M E T



P O O L E N C L O S U R E S

MODEL FAMILY: AQ BOX

Assembly manual

AQBox 

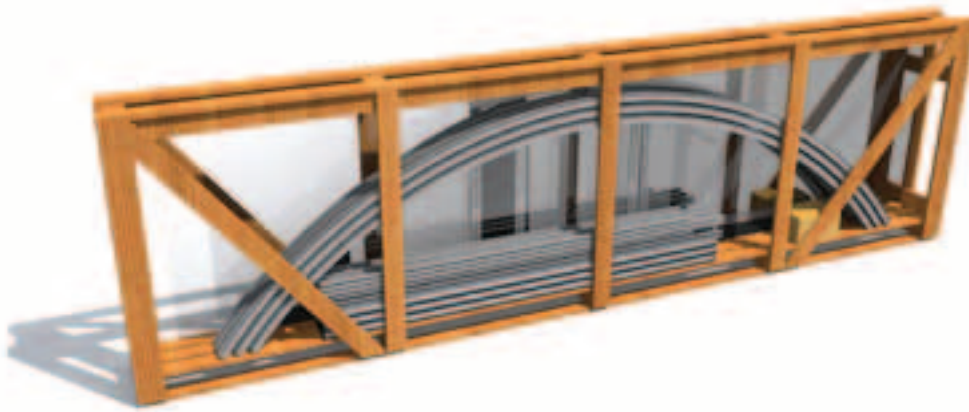

Model		Outside dimensions			weight
	Model	Width	Height	Depth	kg
TH*	M3	5250	1350	410	310
	M4	6700	1840	410	510
	M4/5	6700	1840	410	630
	M5	6500	2000	540	750
CL**	M3	5250	1350	410	350
	M4	6700	1840	410	540
	M4/5	6700	1840	410	660
	M5	6500	2000	540	860

Model		Outside dimensions			weight
	Model	Width	Height	Depth	kg
TH*	A3	4750	1350	410	245
	A3/4	4750	1350	410	320
	A4S	5250	1350	410	310
	A4L	5250	1350	410	340
	A4	5950	1350	410	400
	A4/5	5950	1350	410	475
	A5	6550	1350	500	590
	CL**	A3	4750	1350	410
A3/4		4750	1350	410	400
A4S		5250	1350	410	410
A4L		5250	1350	410	430
A4		5950	1350	410	450
A4/5		5950	1350	410	550
A5		6550	1350	500	760

*TH: PC Thermo = double walled polycarbonate sheet
 **CL: PC Clear = solid, transparent polycarbonate sheet

1

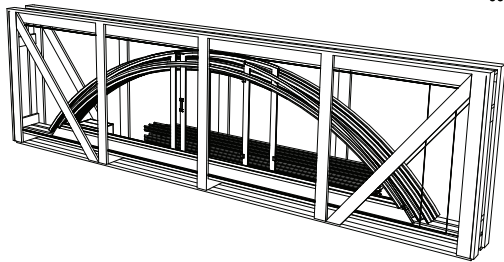

2

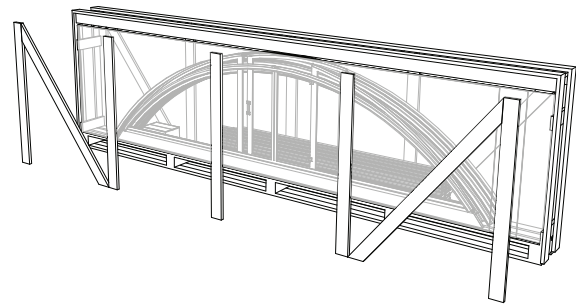

3

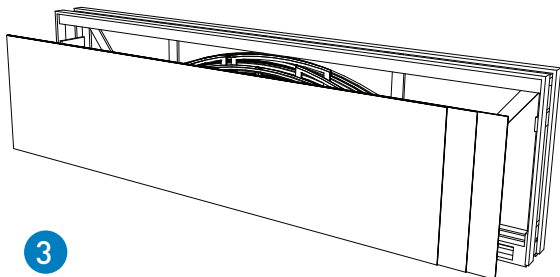

4

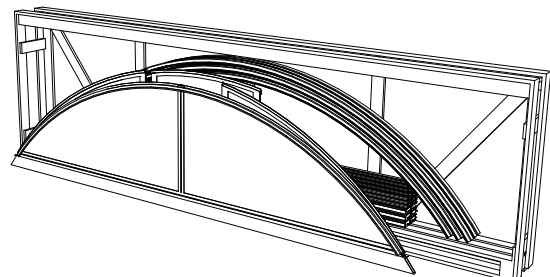

5

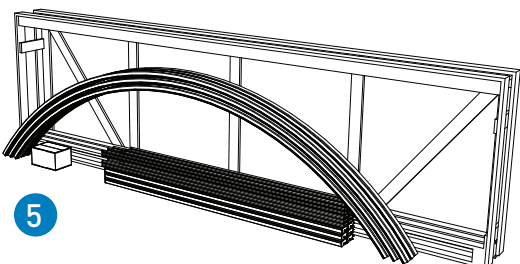



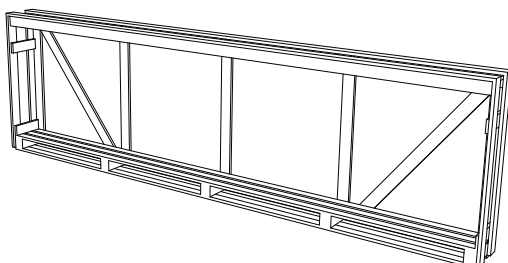





6



PART LIST

<p>1 4,8 x 50 pen head torx screw</p> 	<p>2 4,2 x 10 pen head torx screw + Wedge</p> 	<p>3 Pop rivet 12 mm</p> 	<p>4 Square lock + Flat nut</p> 
<p>5 6x60 pen head torx screw</p> 	<p>6 Anchor</p> 	<p>7 Interior handle</p> 	
<p>8 Handle</p> 	<p>9 Receiver profile cap L - R</p> 	<p>10 Hidden arrest L - R</p> 	
<p>11 Receiver profile cap (on rubber side) L - R</p> 	<p>12 Rocker lever</p> 	<p>13 Latch sleeve</p> 	<p>14 Rail joiner + rail end cap L-R+ buffer</p> 
<p>15 Sliding door lock + plug + key</p> 	<p>16 Front wall fixing nut</p> 	<p>17 Plastic plug + Sliding door buffer + screw</p> 	<p>18 Buffer plate L-R + screw</p> 
<p>19 Sliding door frame rubber seal</p> 	<p>20 Rubber seal between segments</p> 	<p>21 Sliding door bottom rubber</p>  <p>A3 A3/4 A4S A4L A4 A4/5</p>	<p>22 Outside rubber (double)*</p>  <p>*With PC Clear plates</p>

<p>T1</p> 	<p>T2</p>  <p>4.1 mm</p>	<p>T3</p>  <p>3.5 mm</p>	<p>T4</p>  <p>7 mm</p>	<p>T5</p>  <p>TRX 25</p>	<p>T6</p>  <p>TRX 20</p>	<p>T7</p> 	<p>T8</p> 	<p>T9</p> 
--	---	---	---	---	---	---	---	---

1 BOX DISASSEMBLY

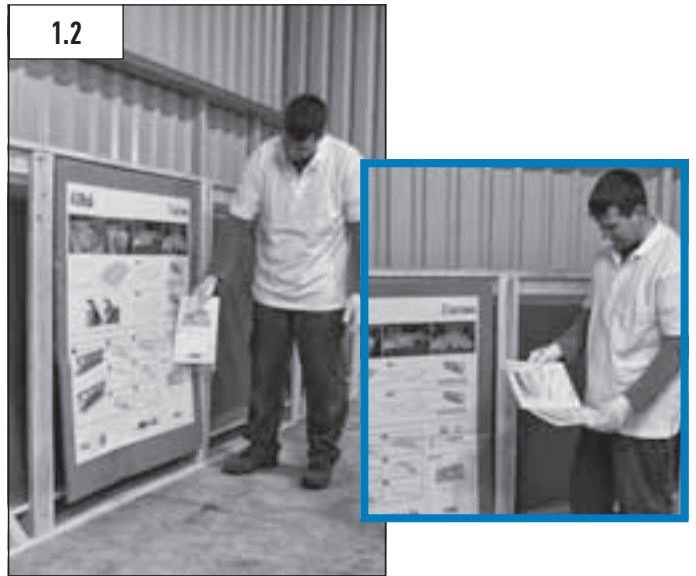

1 BOX DISASSEMBLY

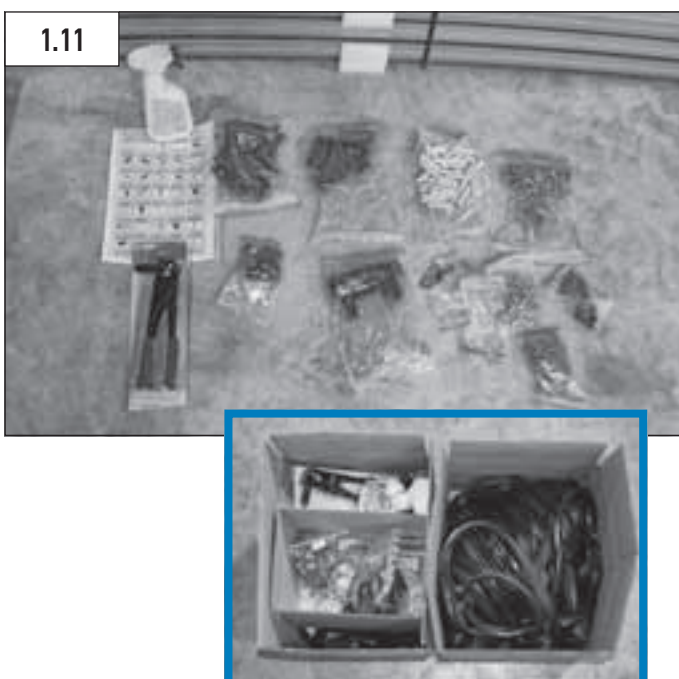

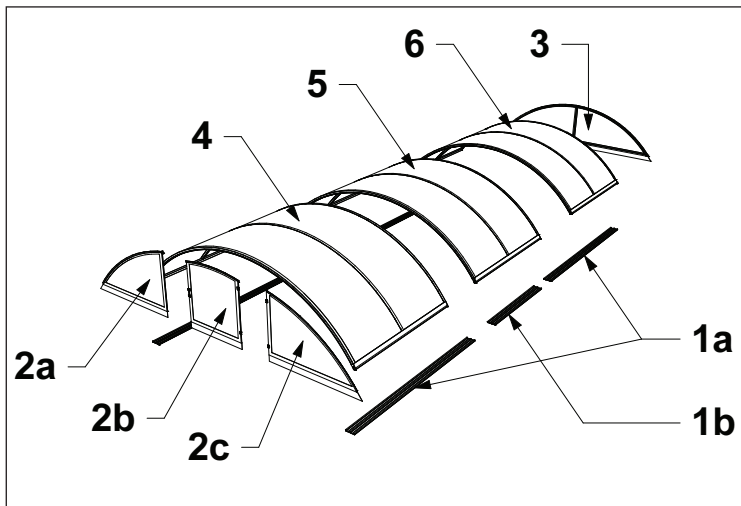

LIST OF ITEMS FOR M3 ENCLOSURES

Nr.	Item name	Item number	Pcs	Chapter
1a	Rail	S3/3	4	2
1b	Rail	S4/3	2	2
2a	Front wall		1	8
2b	Front wall		1	8
2c	Front wall		1	8
3	End wall		1	8
4	1. segment		1	3
5	2. segment		1	4
6	3. segment		1	4

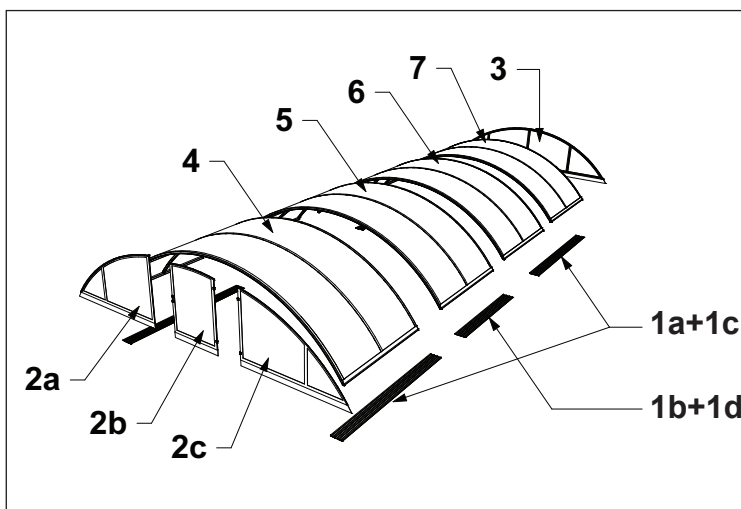

LIST OF ITEMS FOR M4 ENCLOSURES

Nr.	Item name	Item nr.	Pcs	Chapter
1a	Rail	S1/2	4	2
1b	Rail	S3/2	4	2
1c	Rail	S1/2s	2	2
1d	Rail	S3/2s	2	2
2a	Front wall		1	8
2b	Front wall		1	8
2c	Front wall		1	8
3	End wall		1	8
4	1. segment		1	3
5	2. segment		1	4
6	3. segment		1	4
7	4. segment		1	4

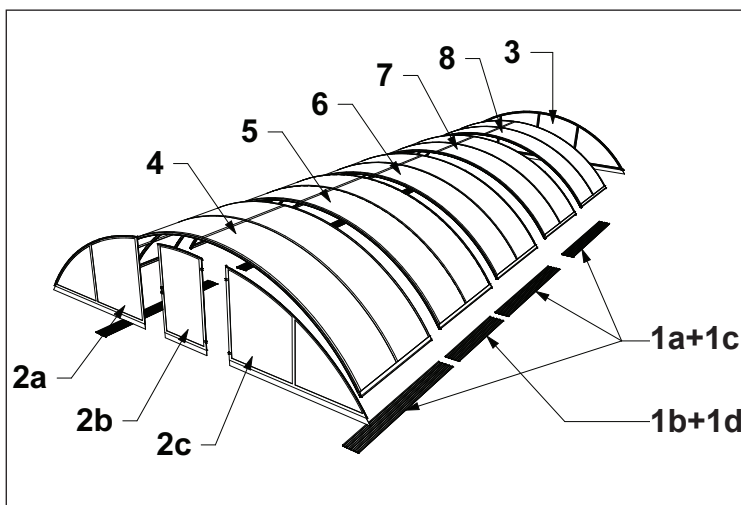

LIST OF ITEMS FOR M4/5, M5 ENCLOSURES

Nr.	Item name	Item number	Pcs	Chapter
1a	Rail	S1/3	6	2
1b	Rail	S7/3	6	2
1c	Rail	S1/2s	4	2
1d	Rail	S7/2s	4	2
2a	Front wall		1	8
2b	Front wall		1	8
2c	Front wall		1	8
3	End wall		1	8
4	1. segment		1	3
5	2. segment		1	4
6	3. segment		1	4
7	4. segment		1	4
8	5. segment		1	4

PART LIST BY ENCLOSURE TYPES

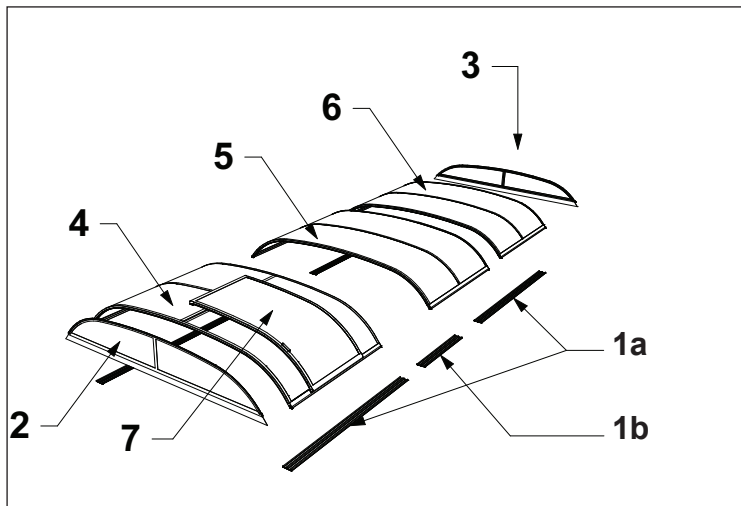

LIST OF ITEMS FOR A3 ENCLOSURES				
Nr.	Item name	Item number	Pcs	Chapter
1a	Rail	S3/3	4	2
1b	Rail	S4/3	2	2
2	Front wall		1	8
3	End wall		1	8
4	1. segment		1	3
5	2. segment		1	4
6	3. segment		1	4
7	Side mounted sliding door		1	6

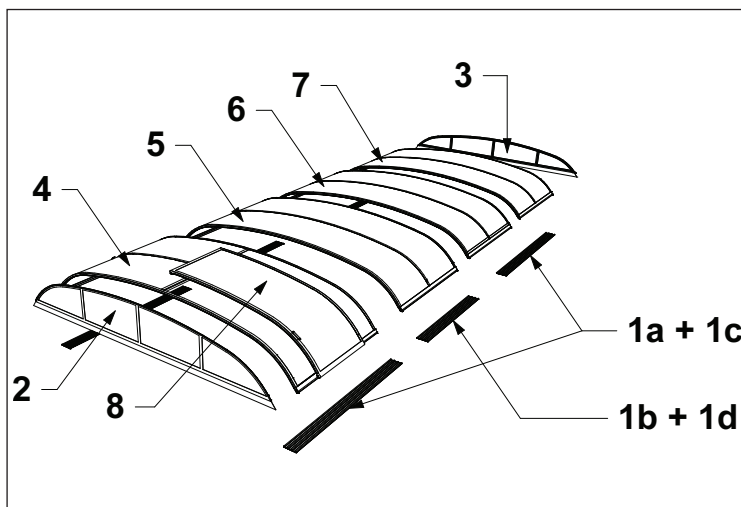

LIST OF ITEMS FOR A3/4, A4S, A4L, A4 ENCLOSURES							
Nr.	Item name	Item number A3/4	Item number A4S	Item number A4L	Item number A4	Pcs	Chp.
1a	Rail	S1/2	S1/2	S1/2	S1/2	4	2
1b	Rail	S5/2	S6/2	S2/2	S3/2	4	2
1c	Rail	S1/2s	S1/2s	S1/2s	S1/2s	2	2
1d	Rail	S5/2s	S6/2s	S2/2s	S3/2s	2	2
2	Front wall					1	8
3	End wall					1	8
4	1. segment					1	3
5	2. segment					1	4
6	3. segment					1	4
7	4. segment					1	4
8	Sliding door					1	6

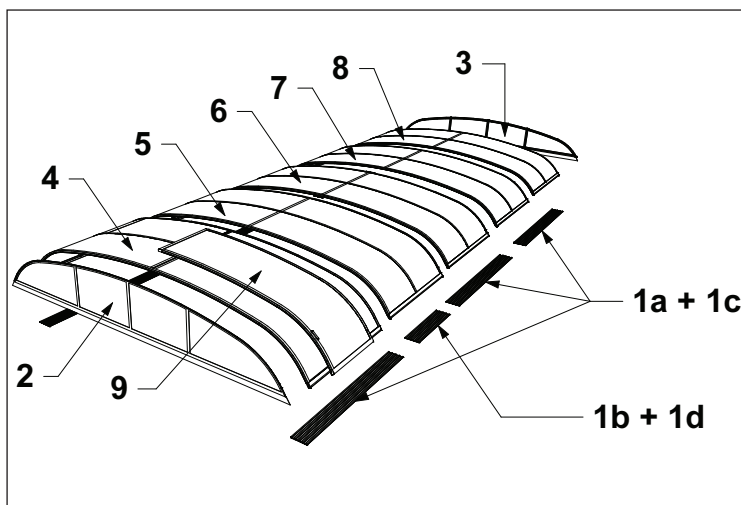

LIST OF ITEMS FOR A4/5, A5 ENCLOSURES				
Nr.	Item name	Item number	Pcs	Chapter
1a	Rail	S1/3	6	2
1b	Rail	S7/3	6	2
1c	Rail	S1/2s	4	2
1d	Rail	S7/2s	4	2
2	Front wall		1	8
3	End wall		1	8
4	1. segment		1	3
5	2. segment		1	4
6	3. segment		1	4
7	4. segment		1	4
8	5. segment		1	4
9	Side mounted sliding door		1	6

Rail placement

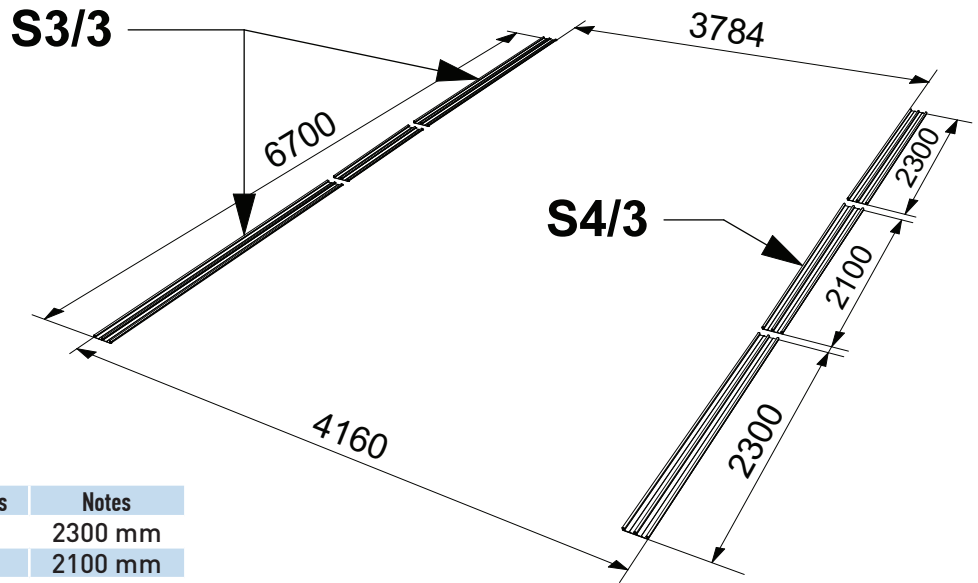

Item Nr.	Item name	Pcs	Notes
S3/3	Rail	4	2300 mm
S4/3	Rail	2	2100 mm
5	Pen head screw	36	6x60
6	Anchor	36	
14a	Rail joiner	12	

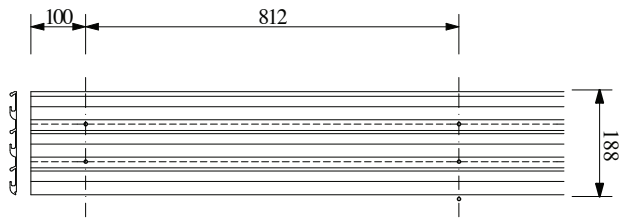

Suggested spots for holes on the rail (depending on the ground surface)

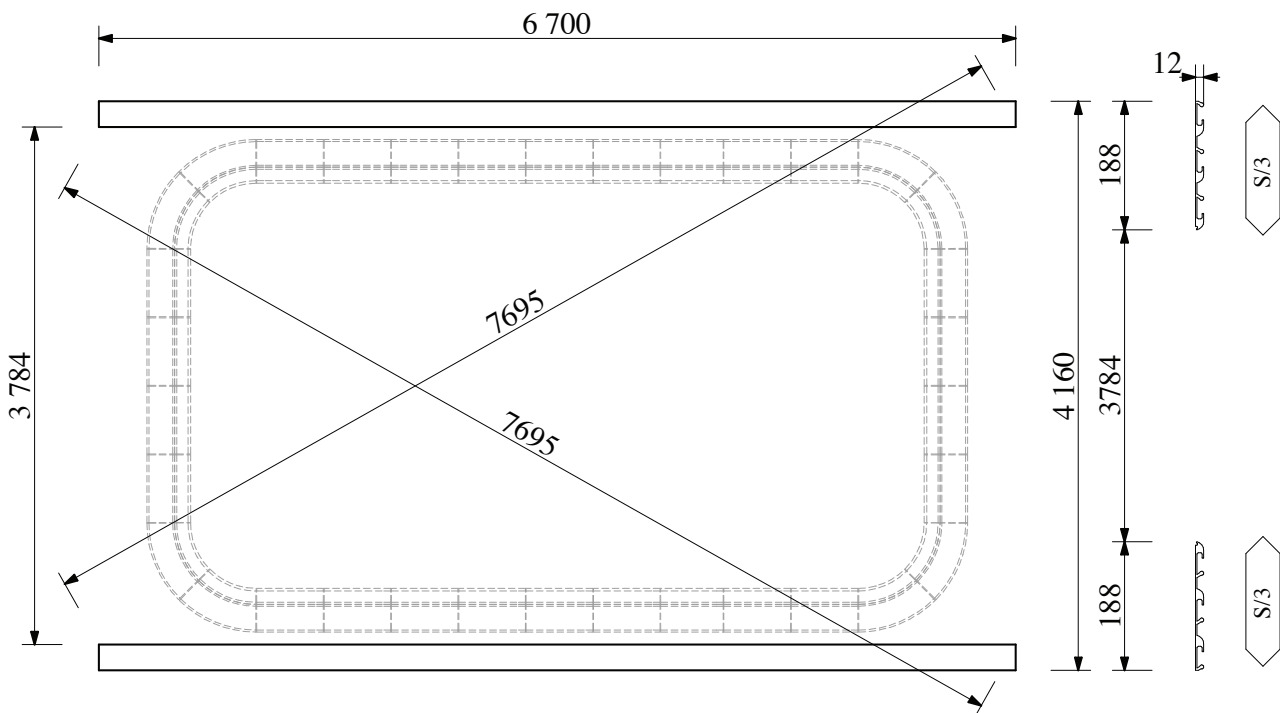
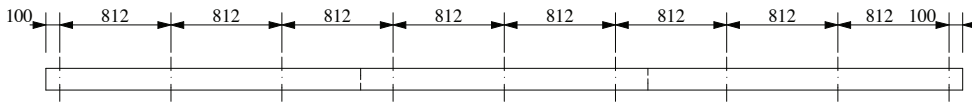

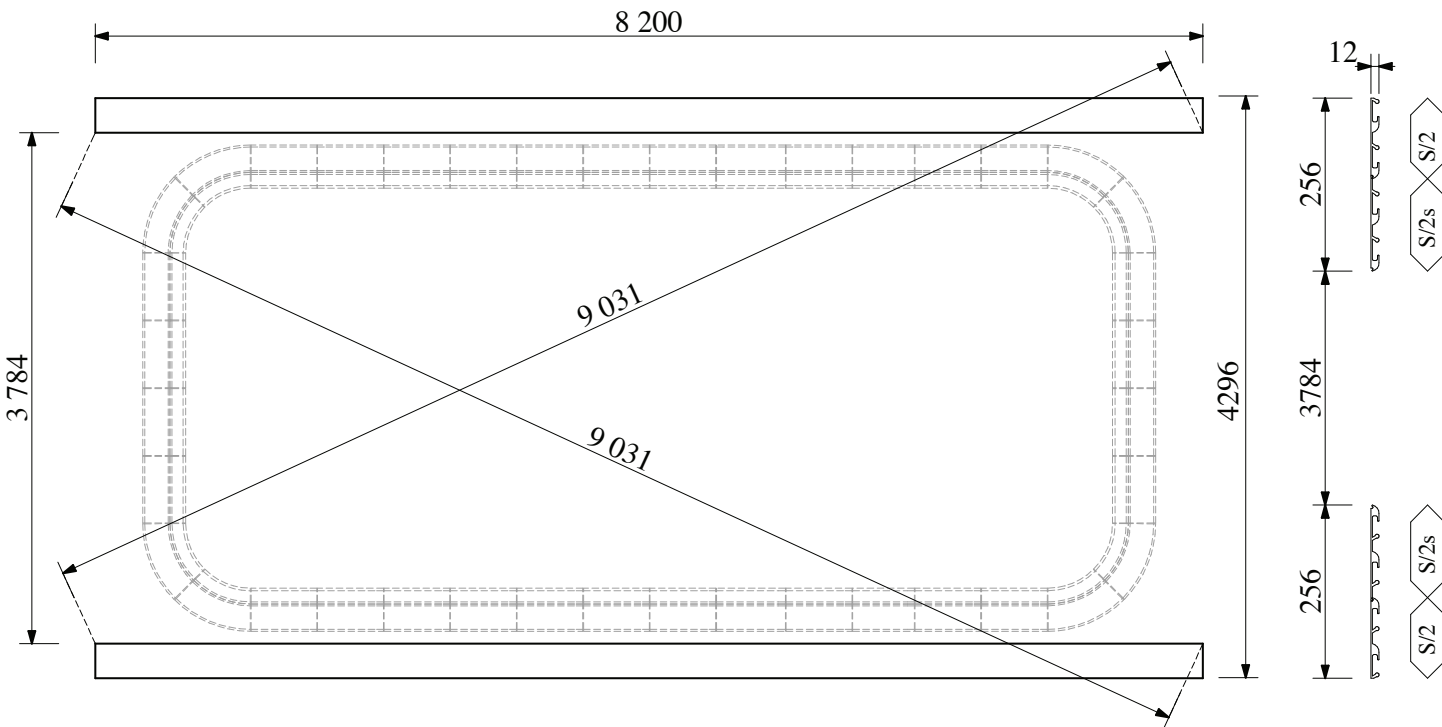
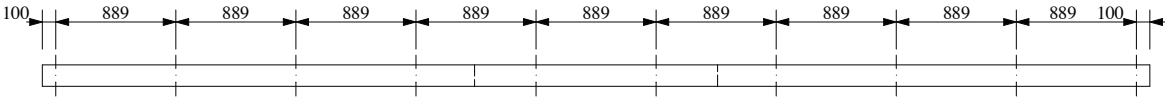
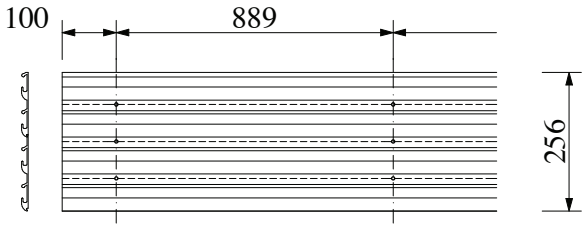
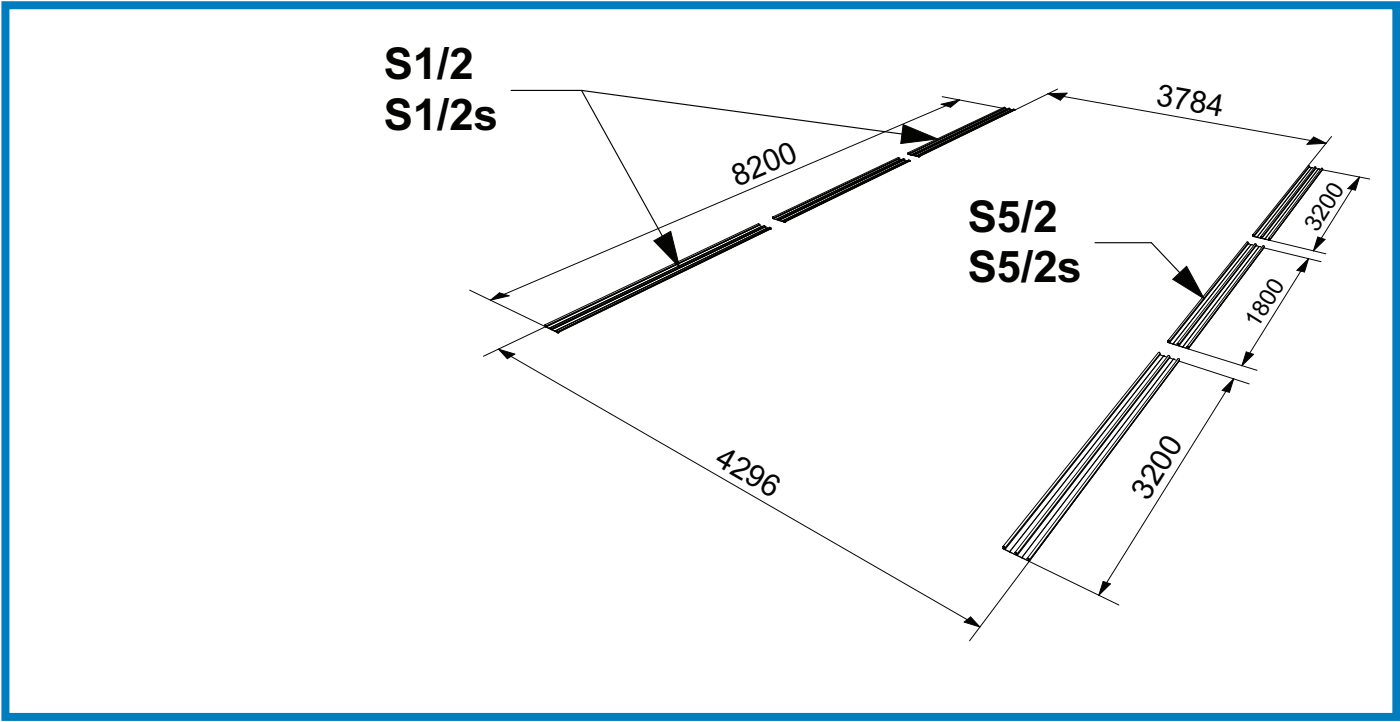

rail placement

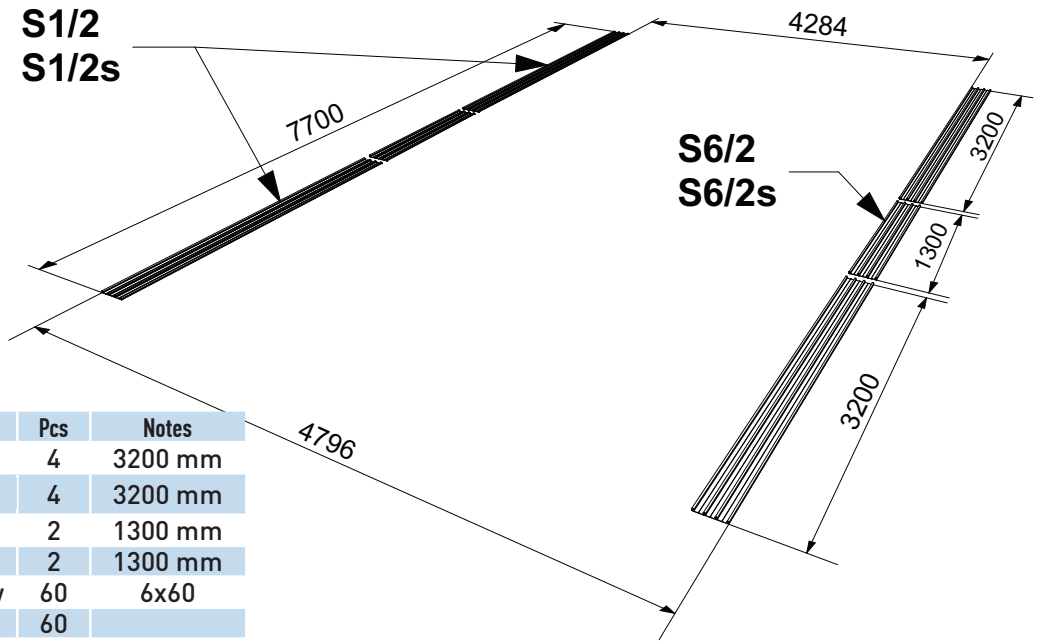

Item Nr.	Item name	Pcs	Notes
S1/2	Rail	4	3200 mm
S1/2s	Rail	4	3200 mm
S6/2	Rail	2	1300 mm
S6/2s	Rail	2	1300 mm
5	Pen head Screw	60	6x60
6	Anchor	60	
14a	Rail joiner	16	

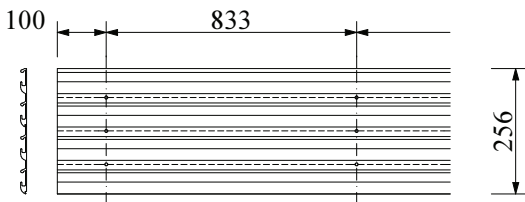

Suggested spots for holes on the rail
(depending on the ground surface)

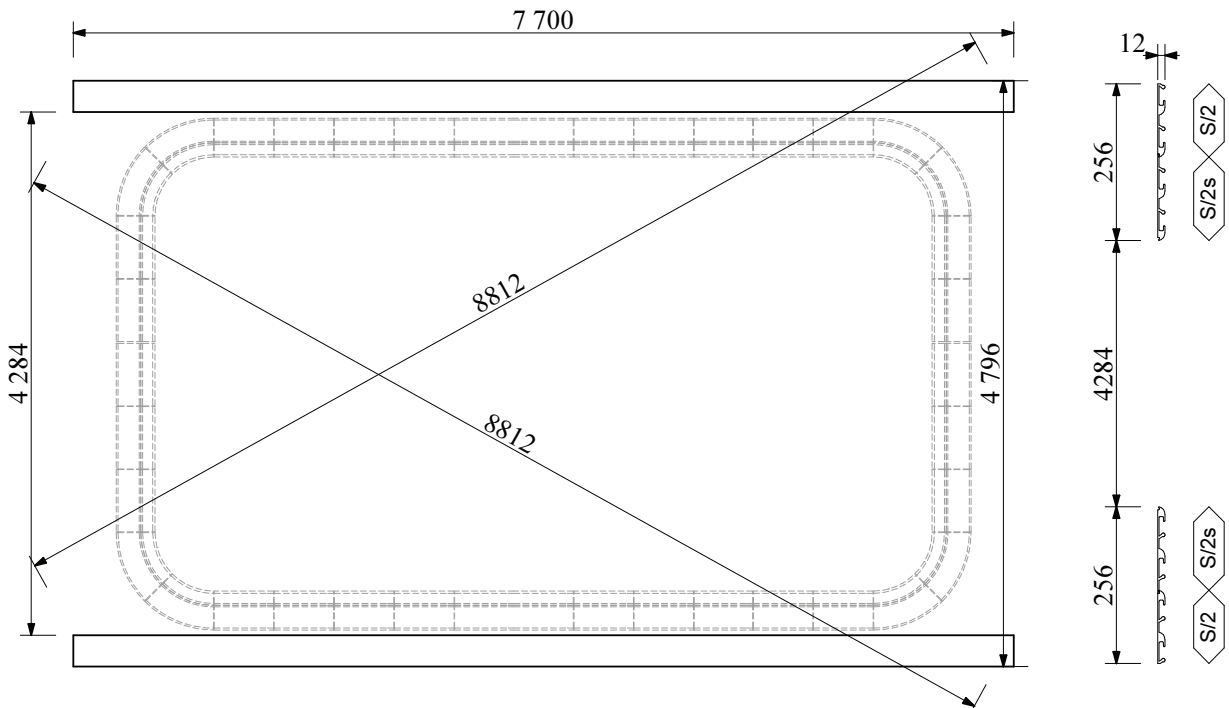
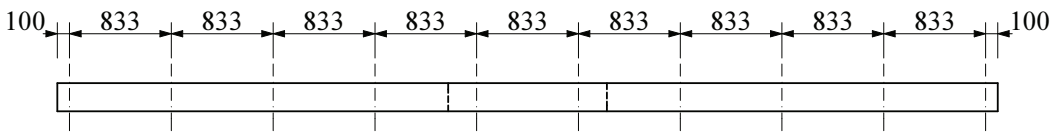

rail placement

Item Nr.	Item name	Pcs	Notes
S1/2	Rail	4	3200 mm
S1/2s	Rail	4	3200 mm
S2/2	Rail	2	2800 mm
S2/2s	Rail	2	2800 mm
5	Pen head Screw	72	6x60
6	Anchor	72	
14a	Rail joiner	16	

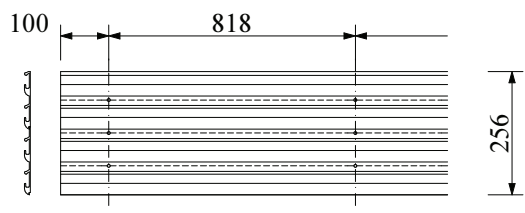

Suggested spots for holes on the rail (depending on the ground surface)

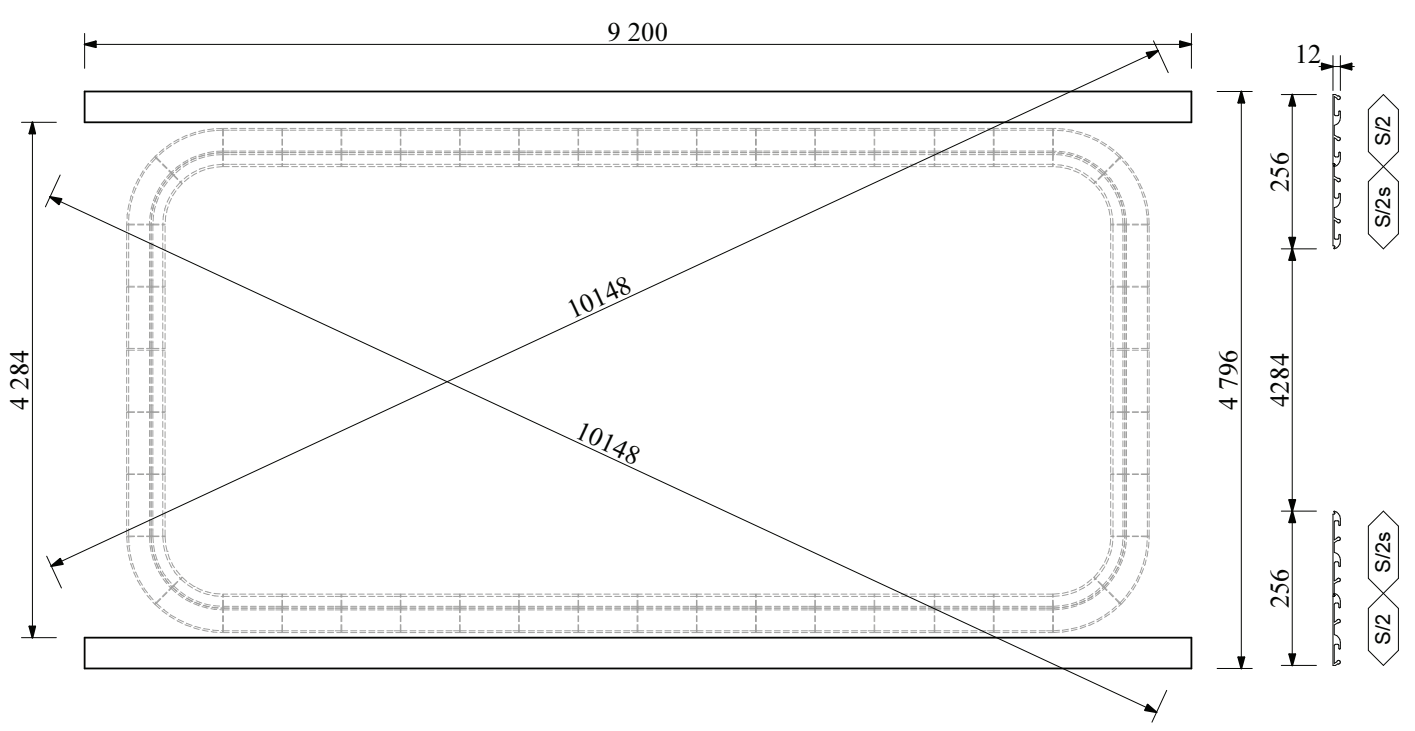
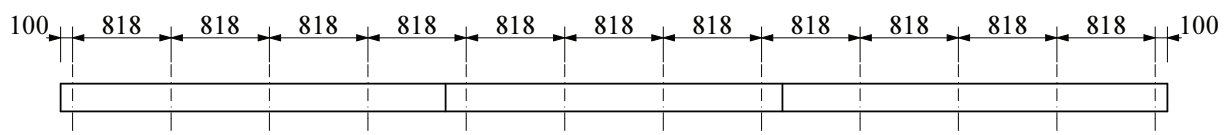

Rail placement

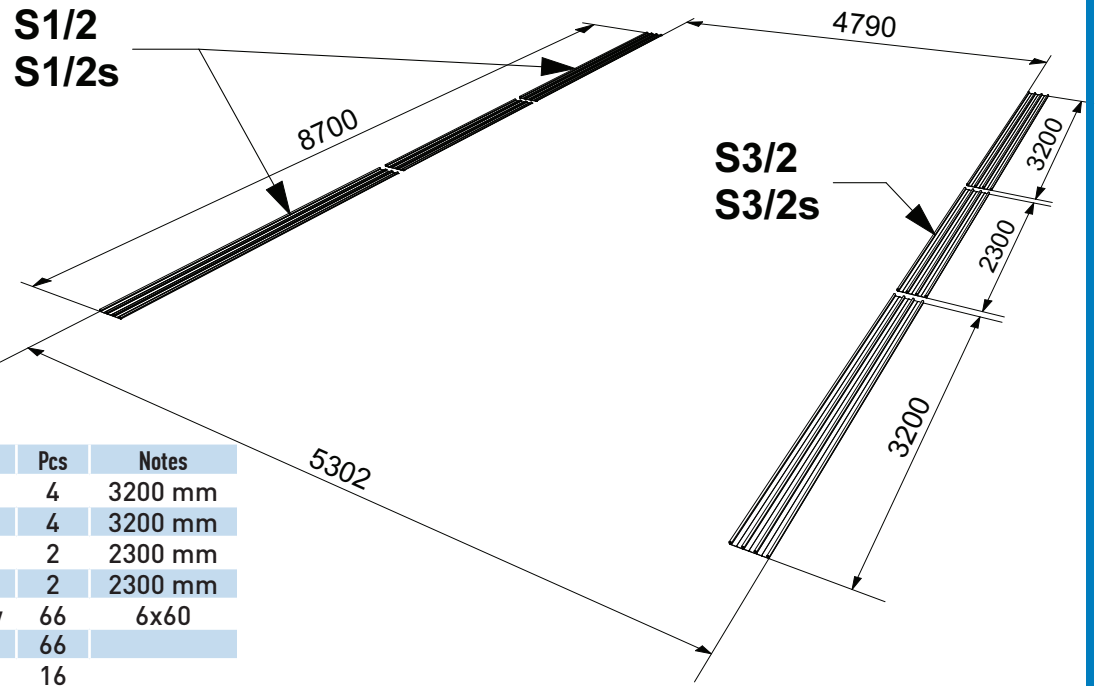

Item Nr.	Item name	Pcs	Notes
S1/2	Rail	4	3200 mm
S1/2s	Rail	4	3200 mm
S3/2	Rail	2	2300 mm
S3/2s	Rail	2	2300 mm
5	Pen head screw	66	6x60
6	Anchor	66	
14a	Rail joiner	16	

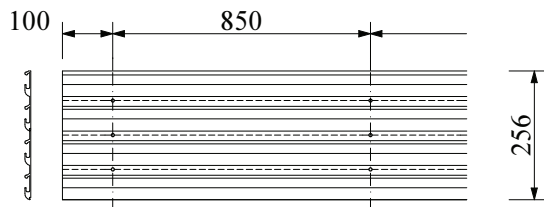

Suggested spots for holes on the rail (depending on the ground surface)

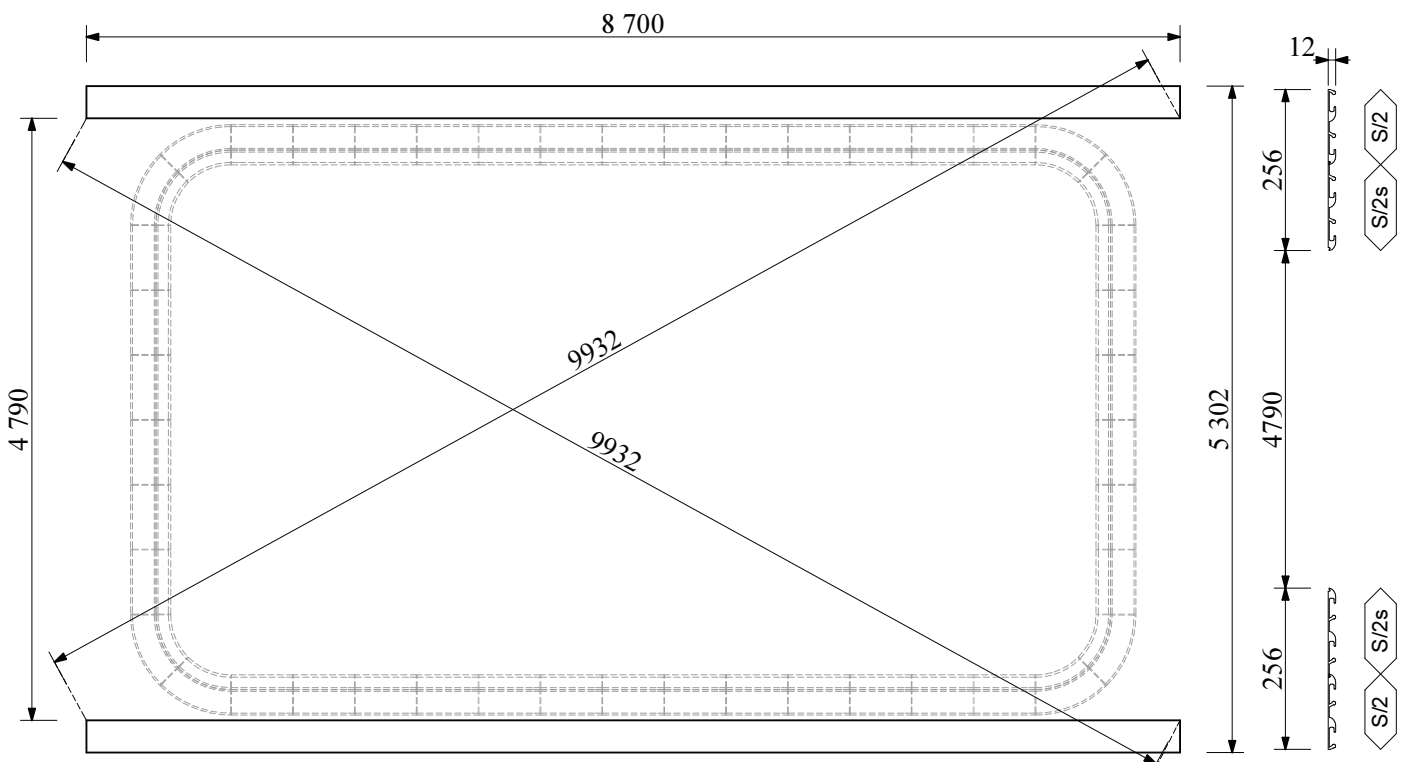
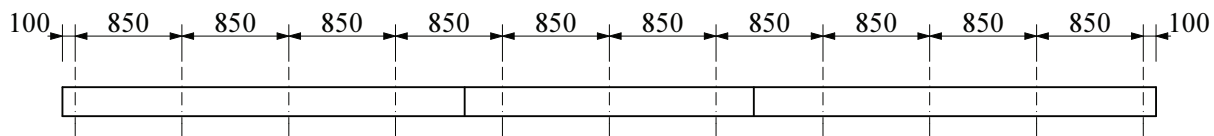

Rail placement

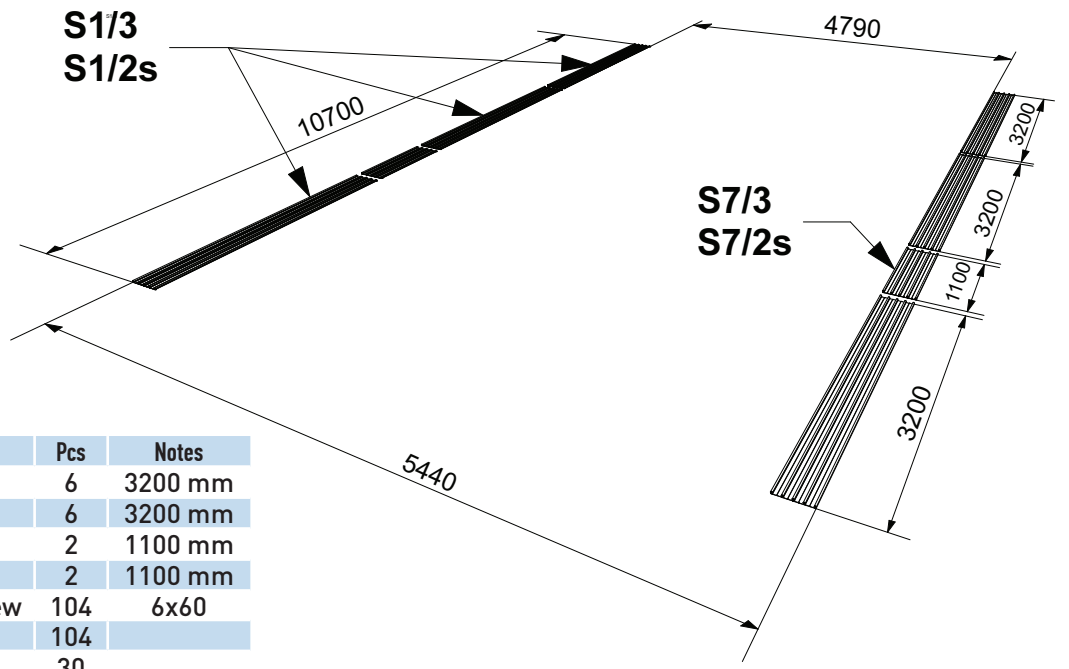

Item Nr.	Item name	Pcs	Notes
S1/3	Rail	6	3200 mm
S1/2s	Rail	6	3200 mm
S7/3	Rail	2	1100 mm
S7/2s	Rail	2	1100 mm
5	Pen head screw	104	6x60
6	Anchor	104	
14a	Rail joiner	30	

Suggested spots for holes on the rail
(depending on the ground surface)

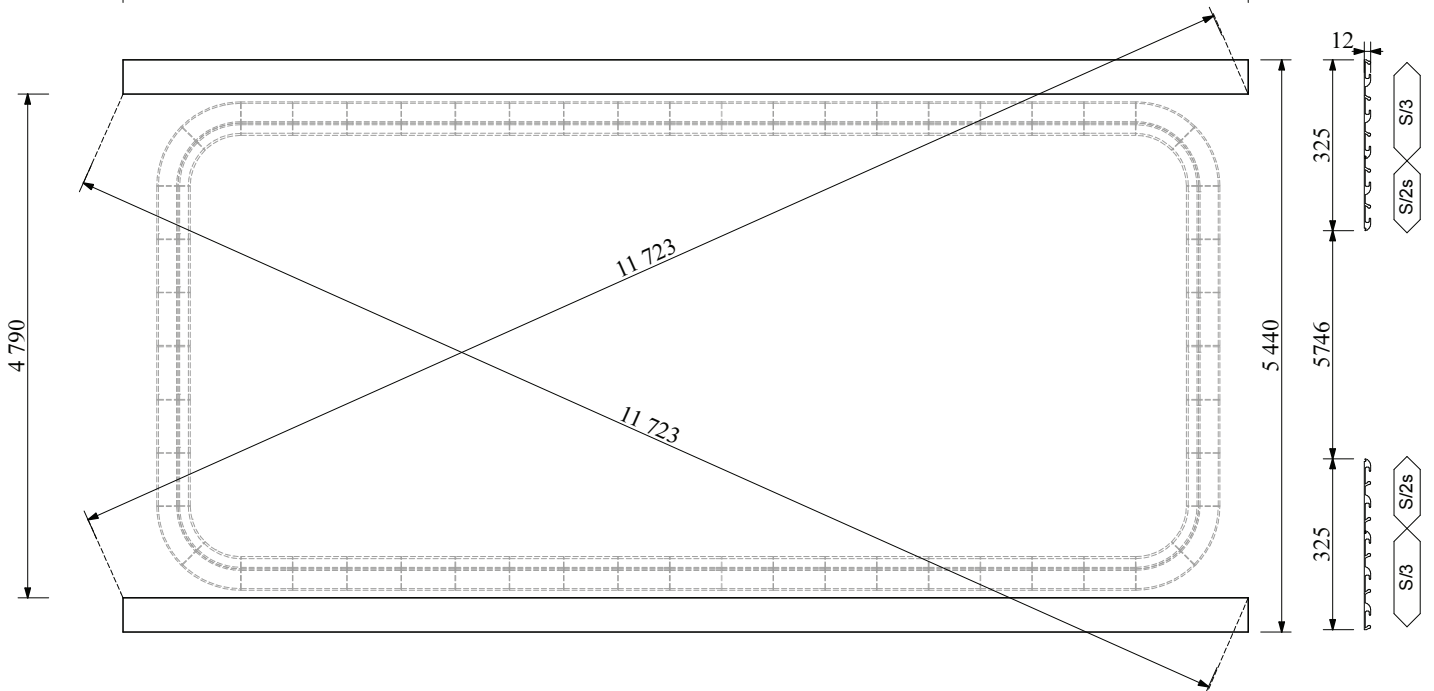
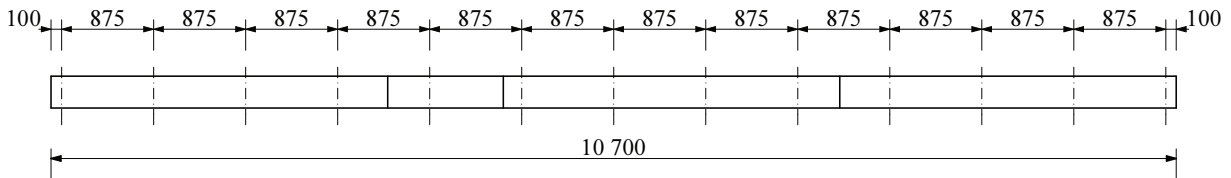
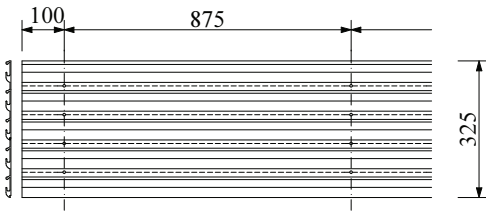

Rail placement

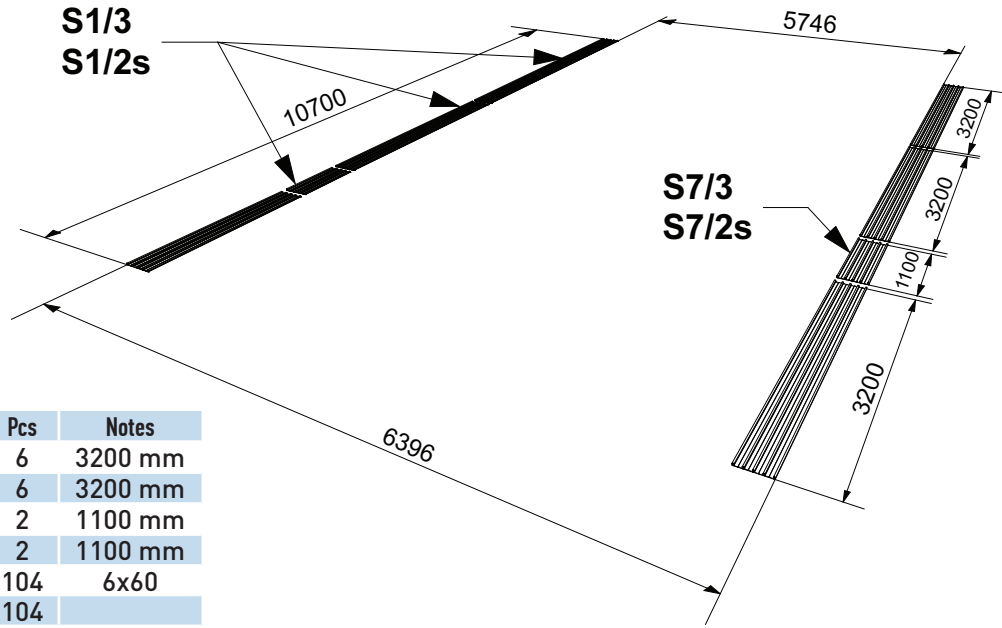

Item Nr.	Item name	Pcs	Notes
S1/3	Rail	6	3200 mm
S1/2s	Rail	6	3200 mm
S7/3	Rail	2	1100 mm
S7/2s	Rail	2	1100 mm
5	Pen head screw	104	6x60
6	Anchor	104	
14a	Rail joiner	30	

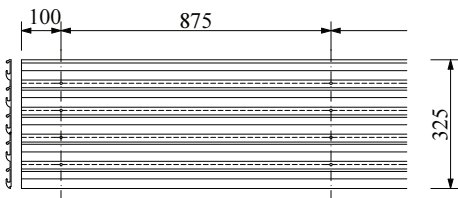

Suggested spots for holes on the rail
(depending on the ground surface)

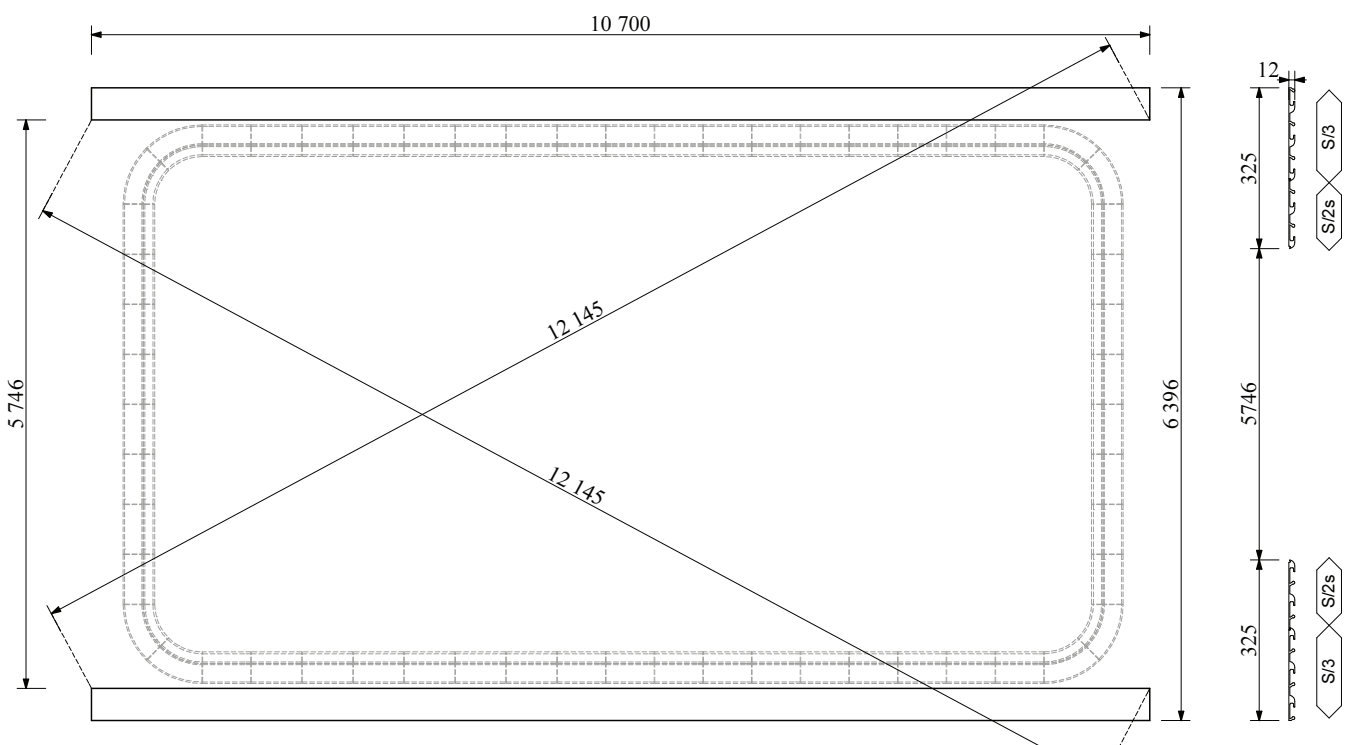
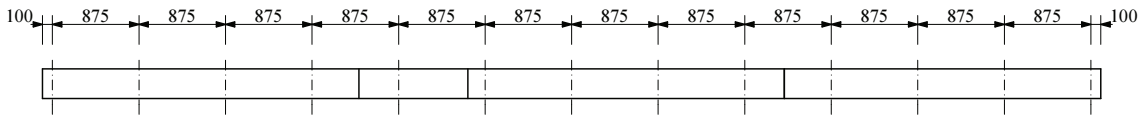

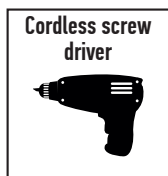
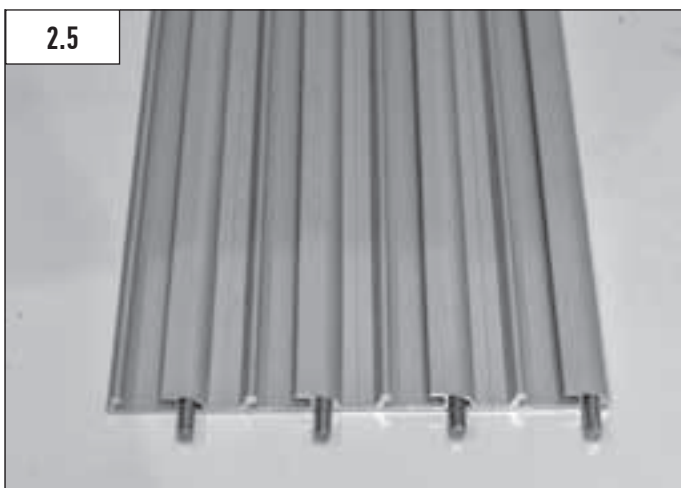
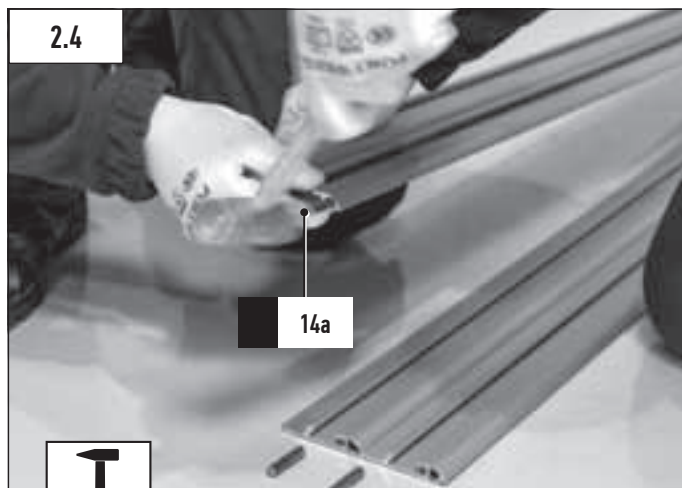
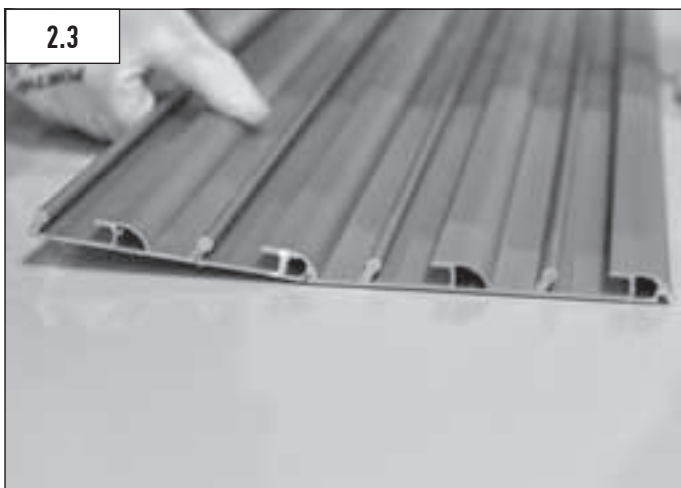

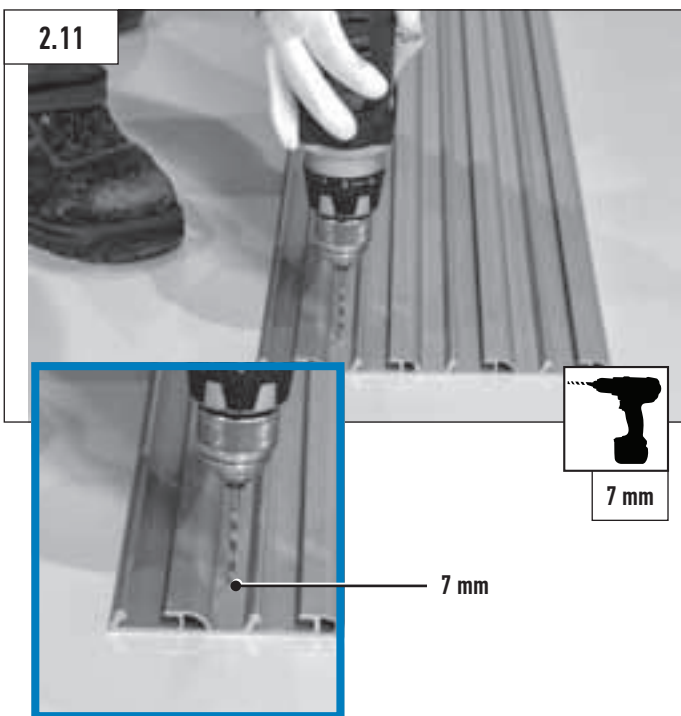
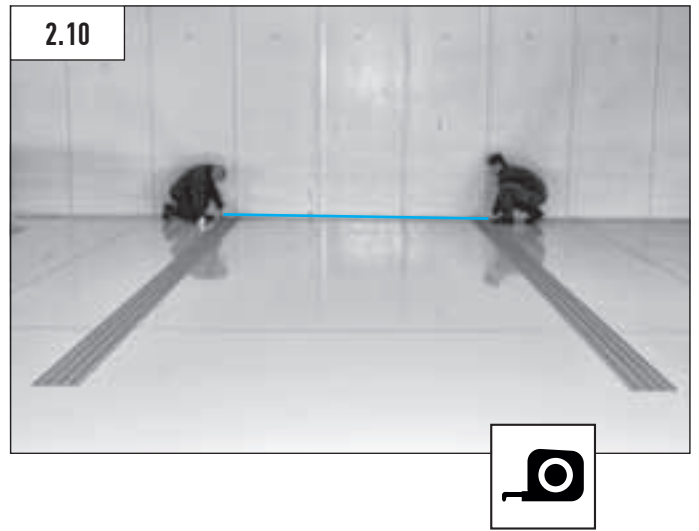
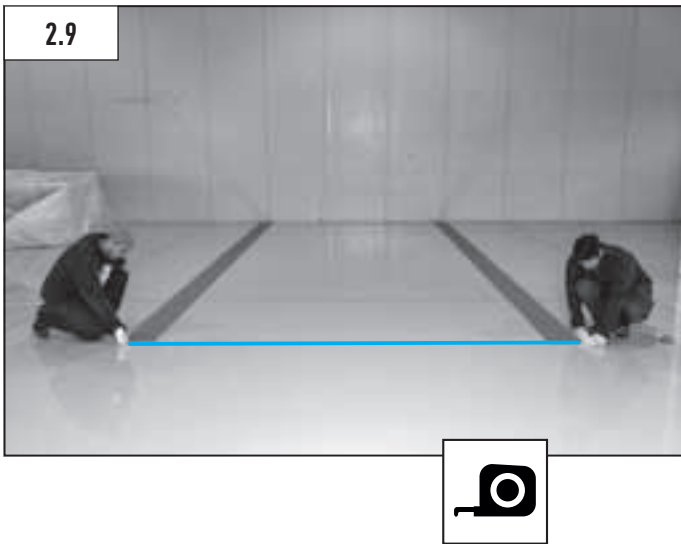
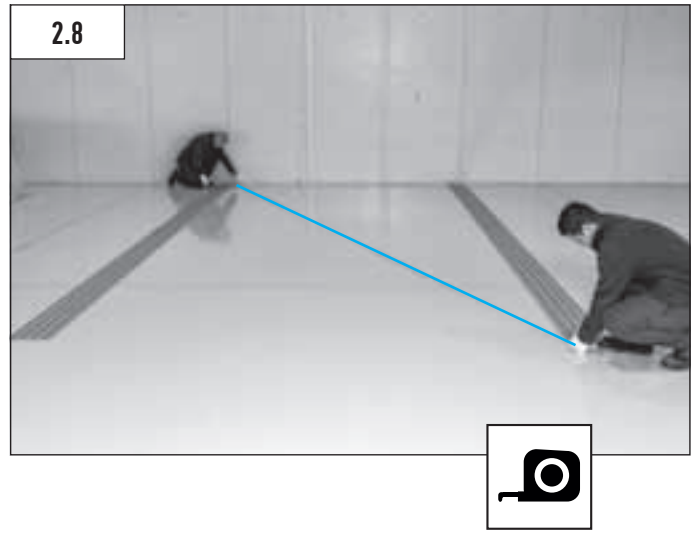

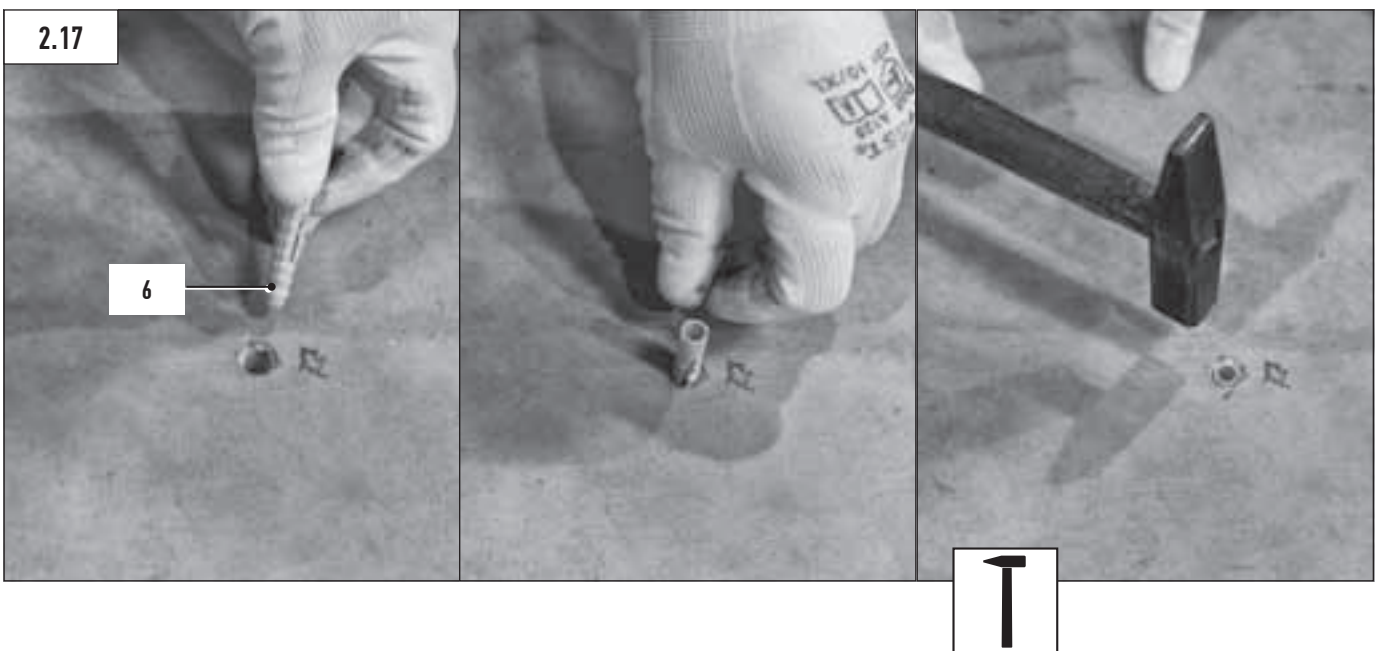
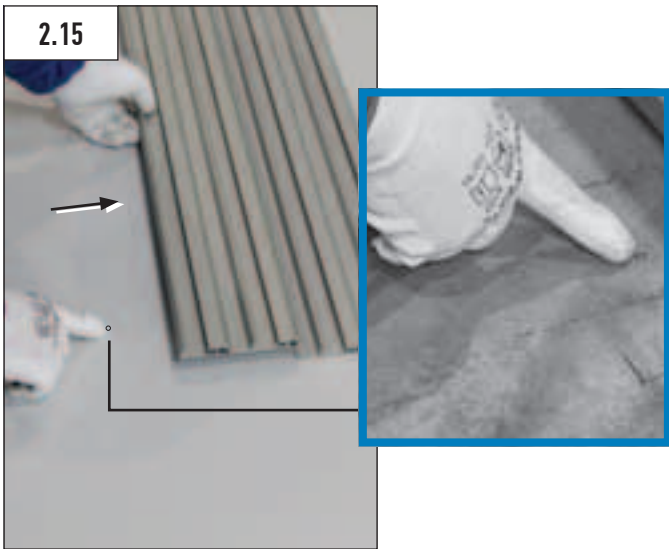
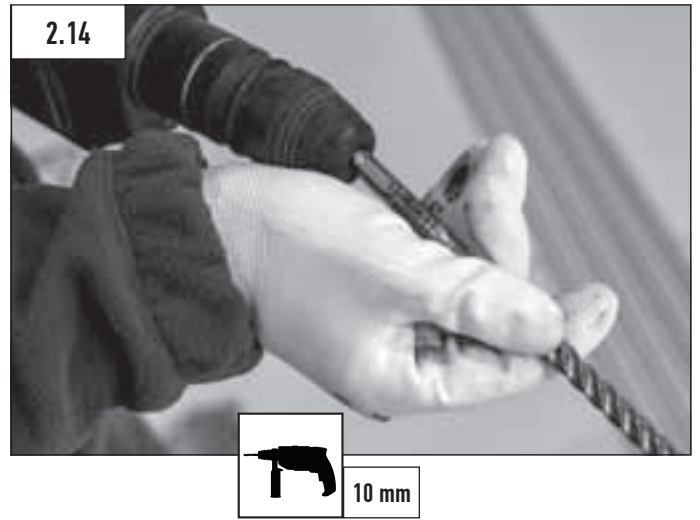
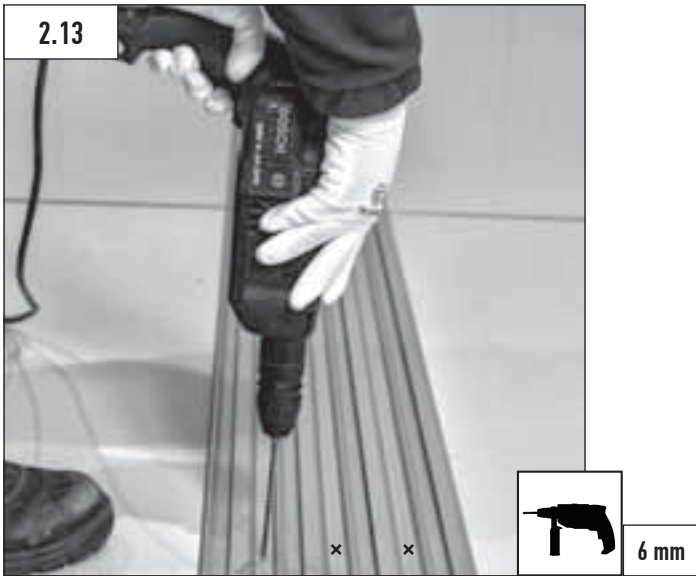

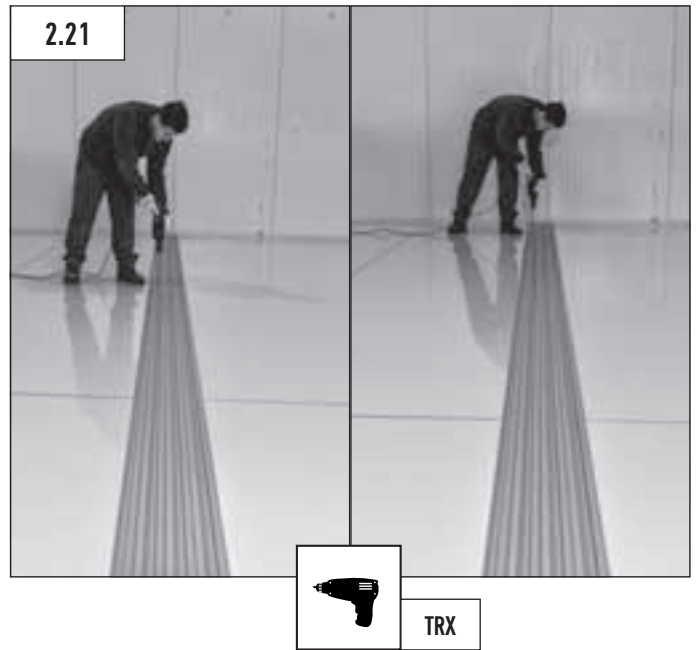
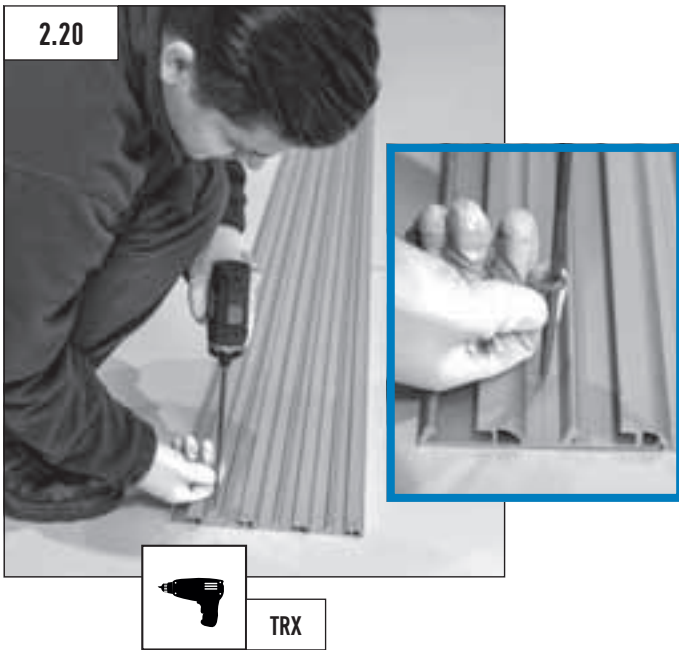
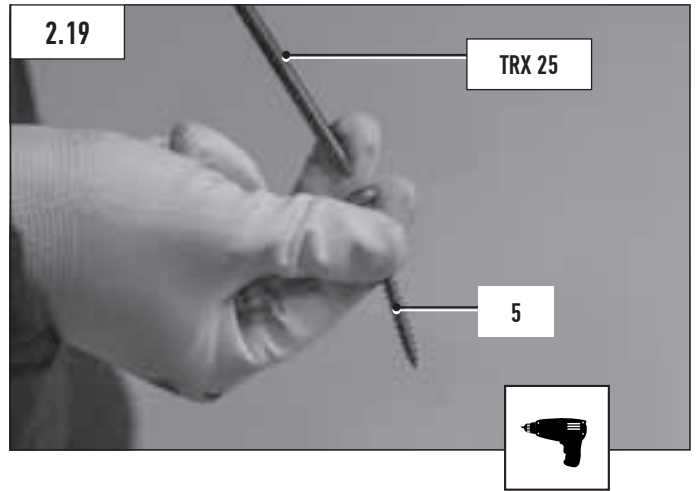

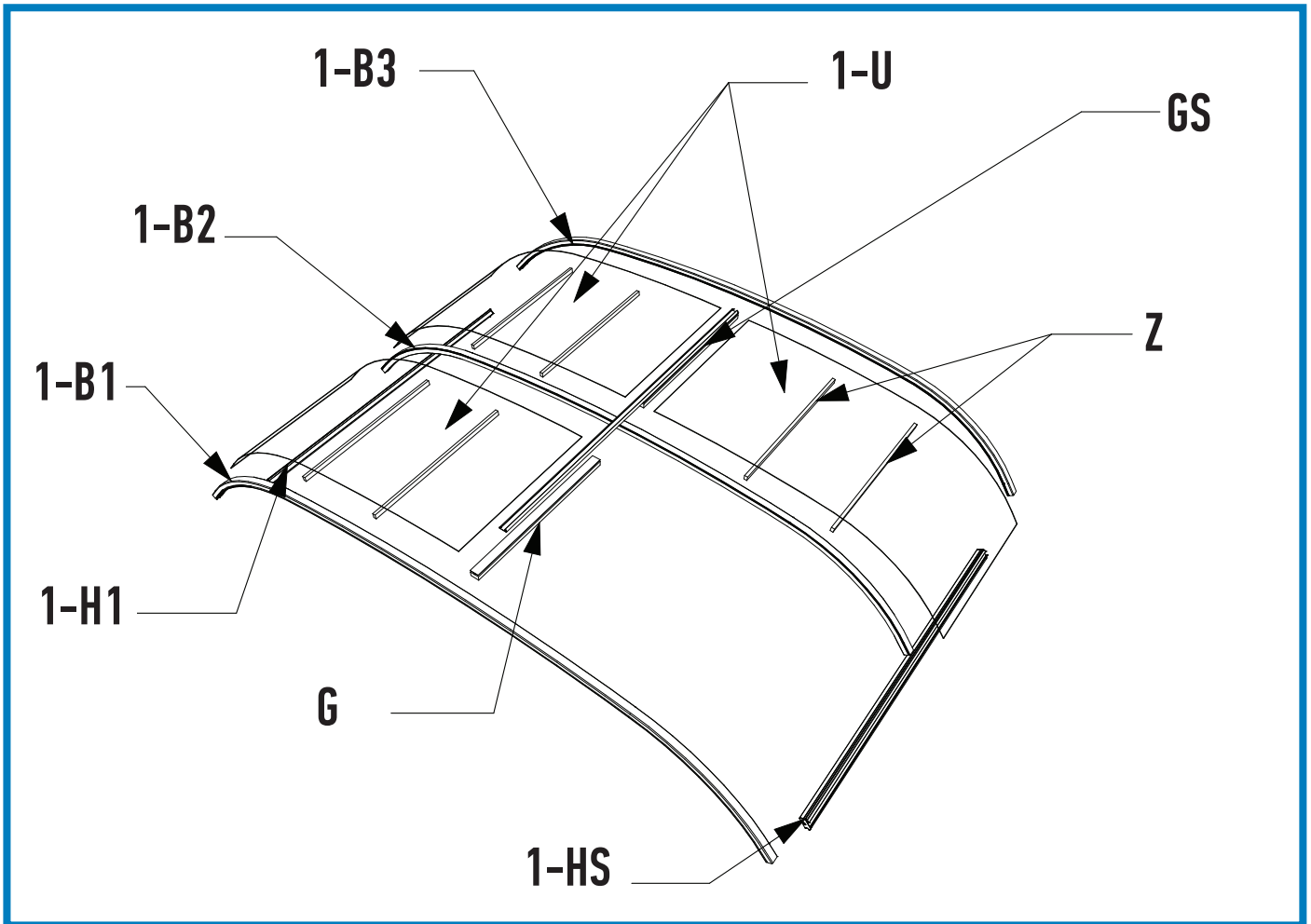

Item nr.	Item name	Pcs	Pcs	Notes
1-B1	1. arch	1	1	
1-B2	2. arch	1	1	
1-B3	3. arch	1	1	
1-H	Receiver profile	1	1	
1-HS	Receiver profile with rail	1	1	
1-U	PC Clear plate / PC Thermo plate	3	3	
Z	Linking hollow section	6	9	
G	Linking profile	1	1	
GS	Linking profile with rail	1	1	
1	Pen head torx screw	12	12	4,8 x 50
4	Square lock	1	1	
9	Receiver profile cap (L -R)	2	2	1 right + 1 left
10	Hidden arrest	1	1	1 right + 1 left
18	Buffer plate	1	1	1 right + 1 left
22	Outside rubber (double)*			

* with PC Clear plate

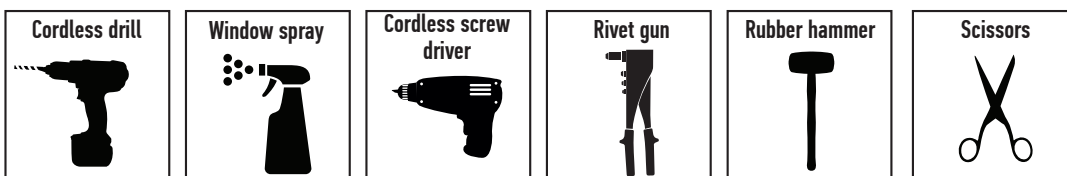

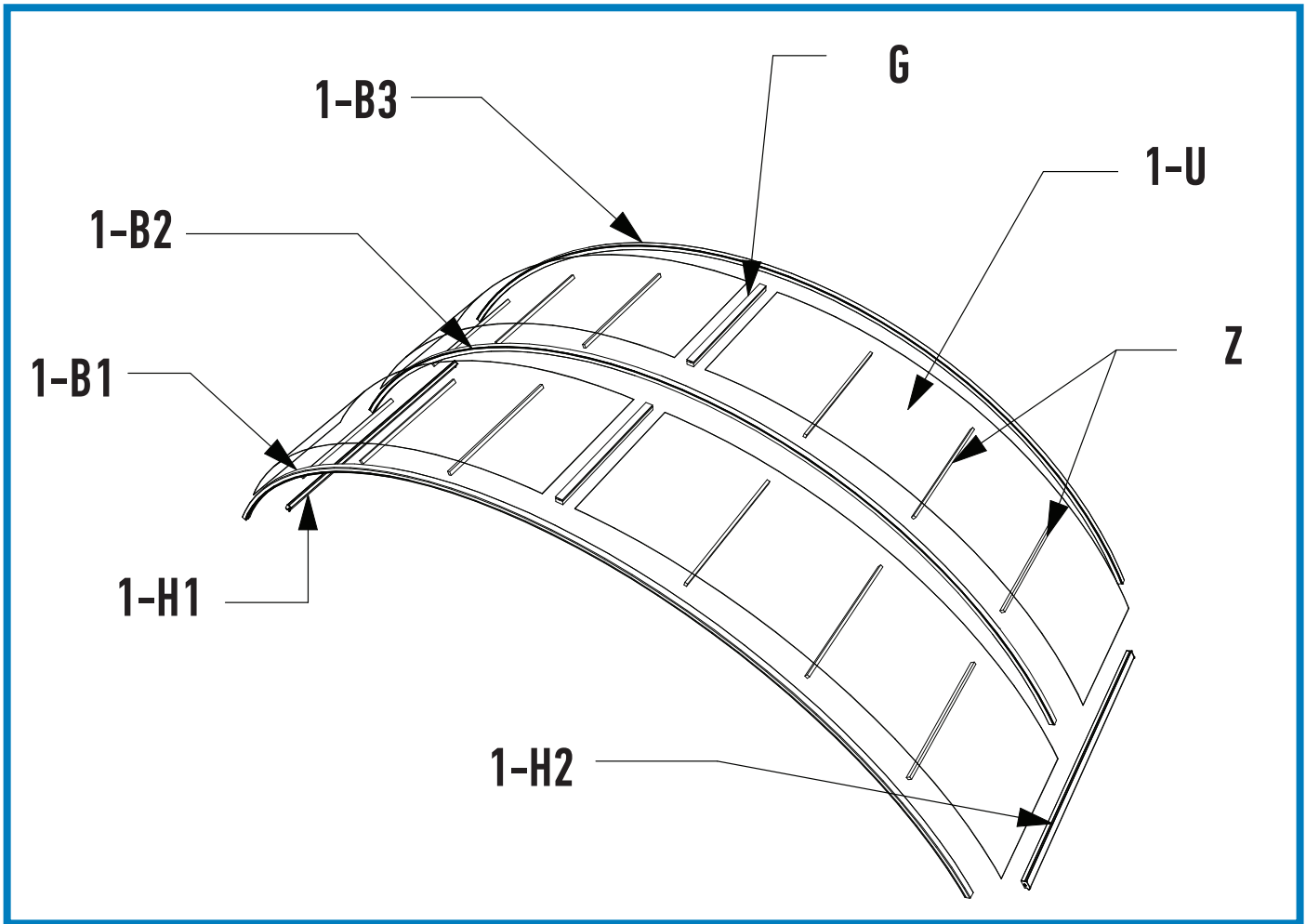

Item nr.	Item name				Notes
		M3	M4	M4/5	
1-B1	1. arch	1	1	1	
1-B2	2. arch	1	1	1	
1-B3	3. arch	1	1	1	
1-H1	Receiver profile - right	1	1	1	
1-H2	Receiver profile - left	1	1	1	
1-U	PC Clear plate / PC Thermo plate	2	2	4	
Z	Linking hollow section	8	10	12	
G	Linking profile	-	-	2	
1	Pen head torx screw	12	12	12	4,8 x 50
2	Square lock	1	1	1	
3	Hidden arrest	1	1	1	1 right + 1 left
9	Receiver profile cap (L -R)	2	2	2	1 right + 1 left
10	Buffer plate	1	1	1	1 right + 1 left
22	Outside rubber (double)*				

*with PC Clear plate

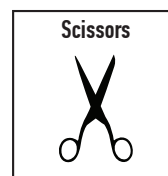
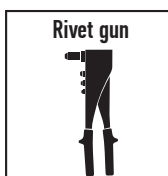

3 FIRST SEGMENT ASSEMBLY

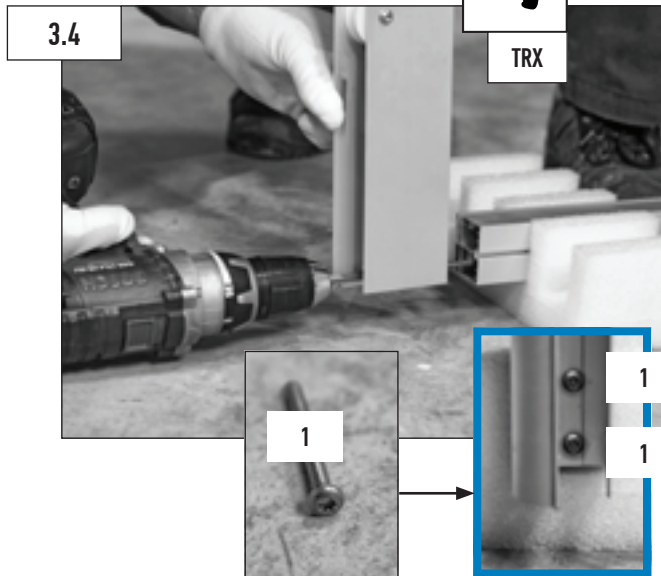
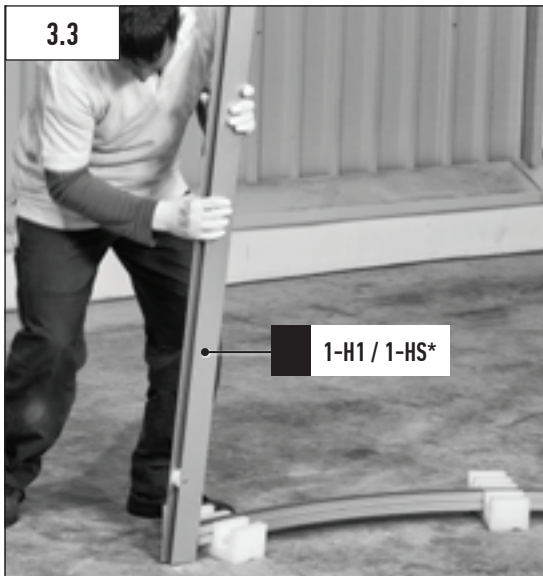
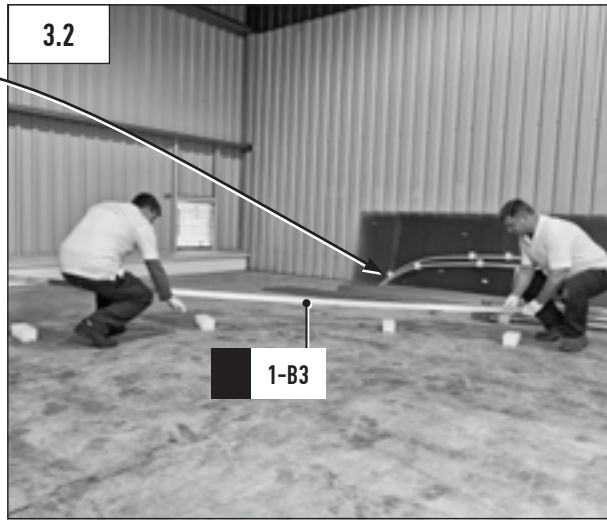
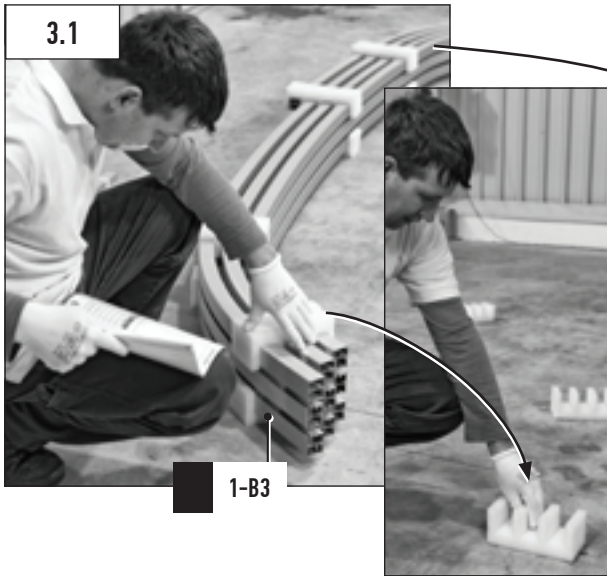

* 1-HS =
at the sliding door

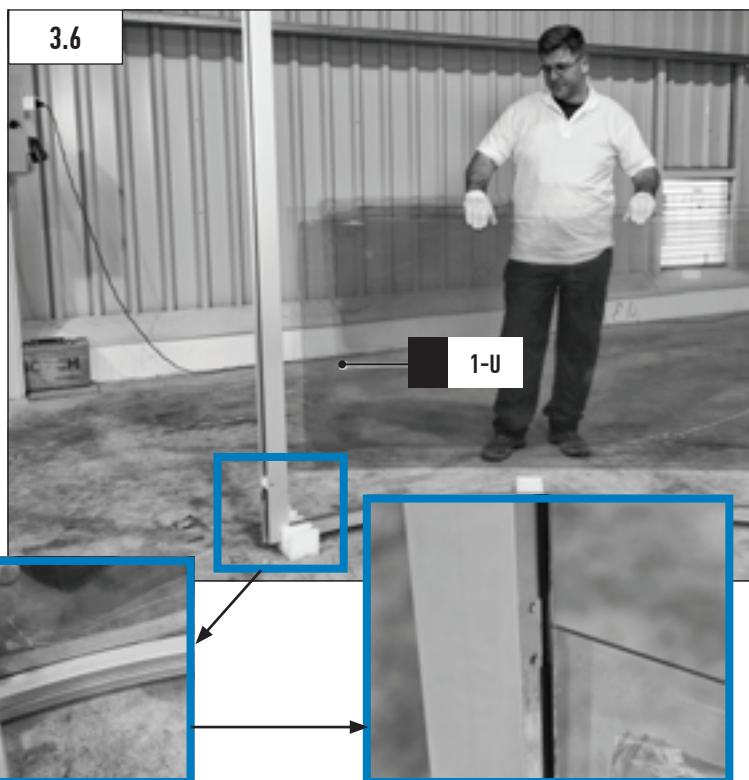

3 FIRST SEGMENT ASSEMBLY

*M5

** A3, A3/4, A4S, A4L, A4, A4/5, A5

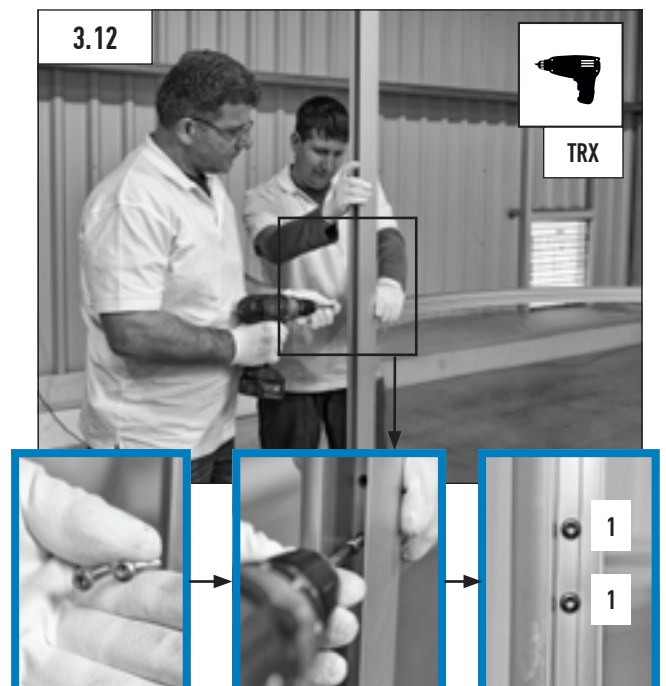
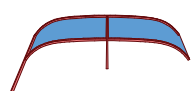
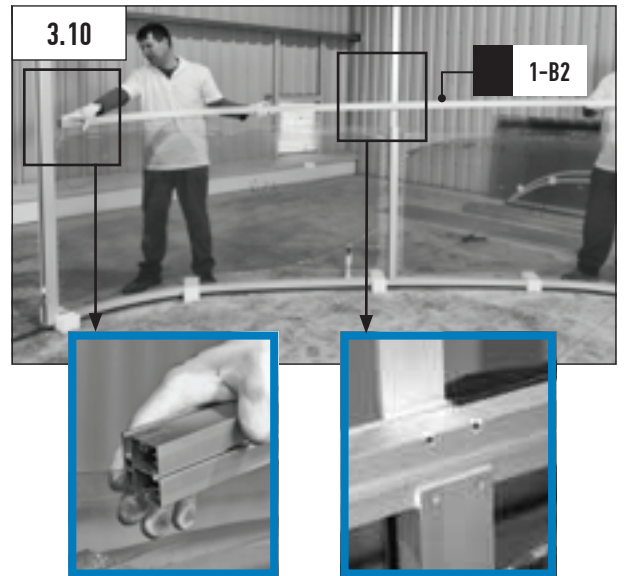
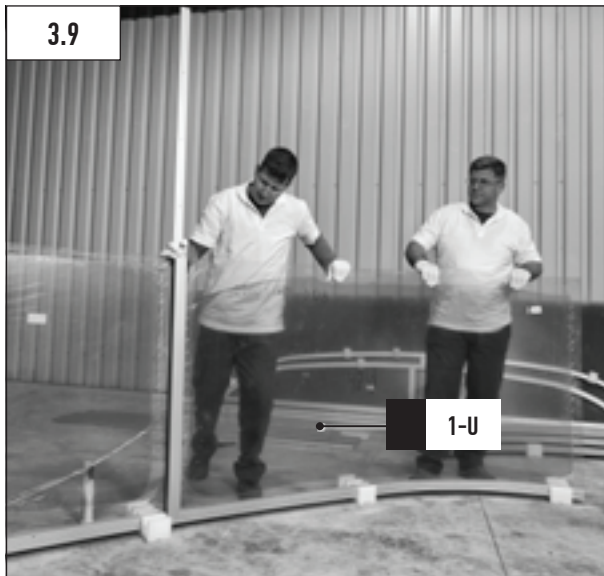
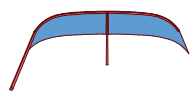
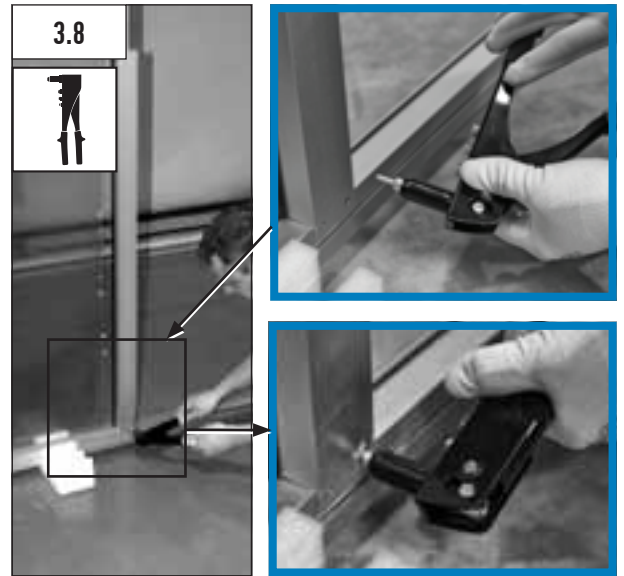
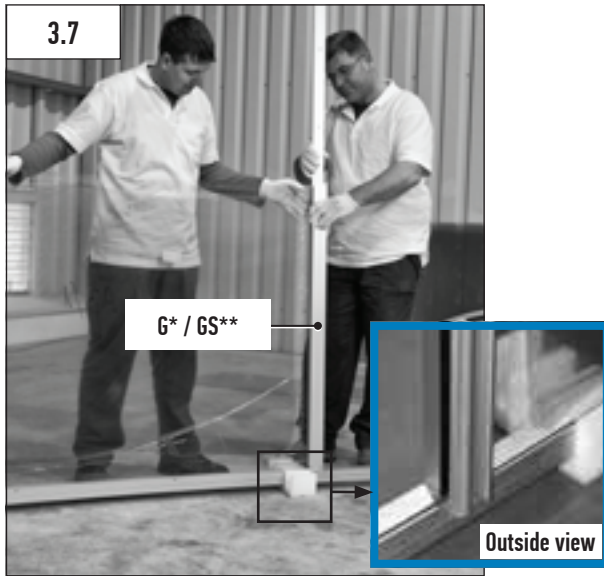
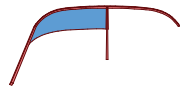

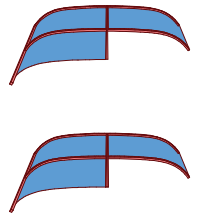
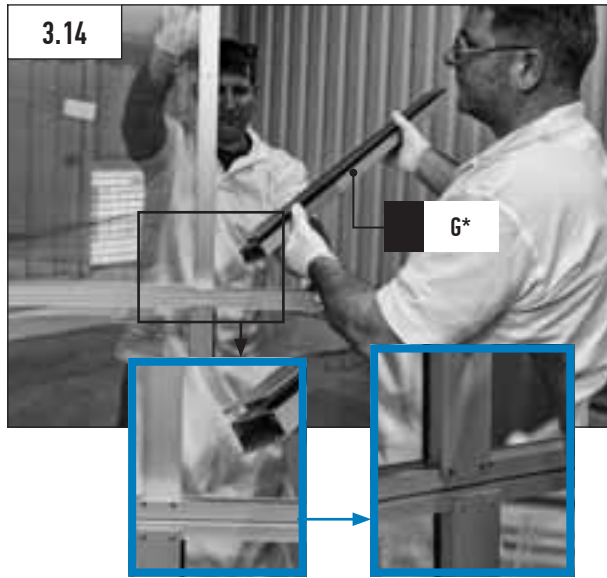
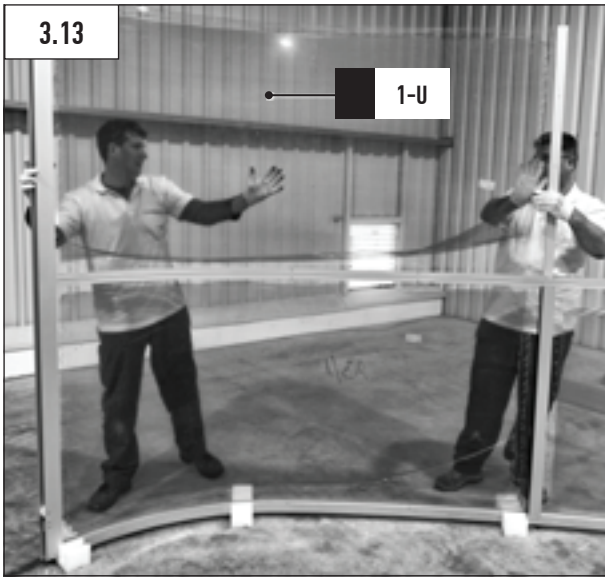

*A3, A3/4, A4S, A4L, A4, A4/5, A5, M5

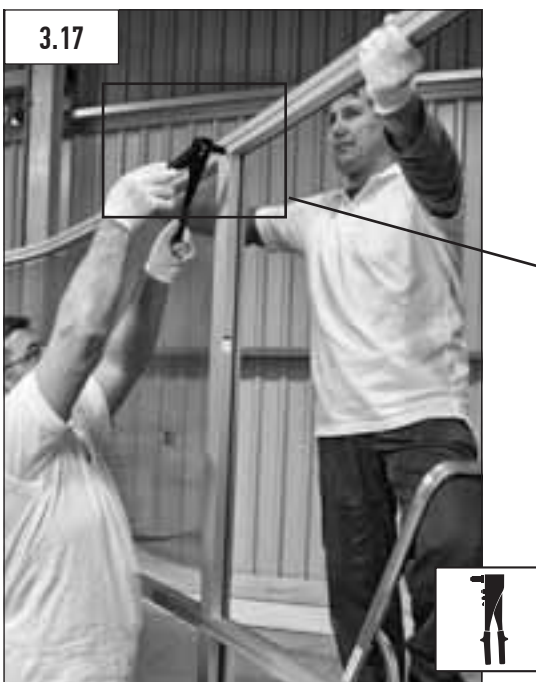
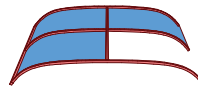
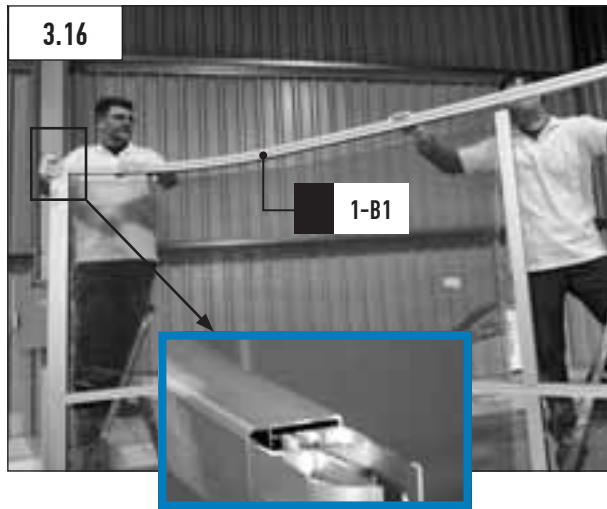

3 FIRST SEGMENT ASSEMBLY

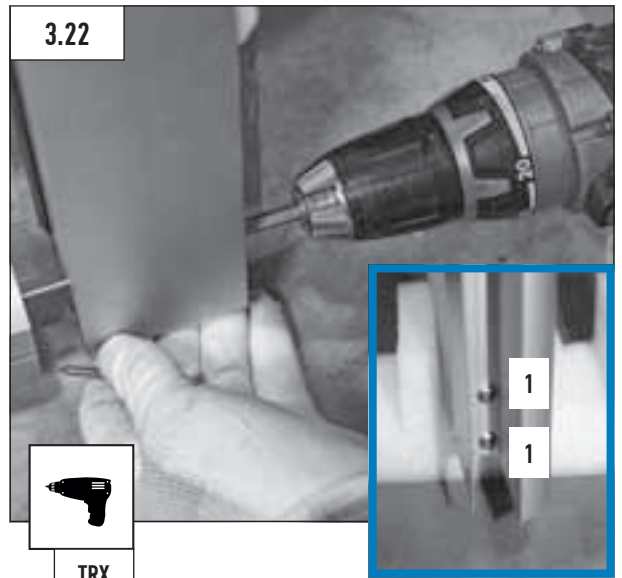
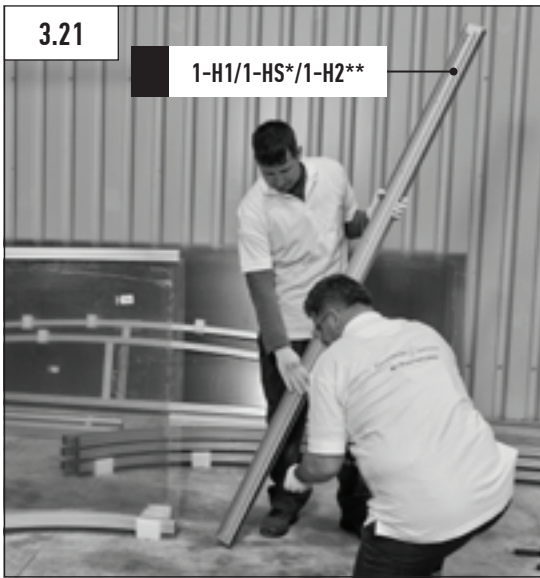
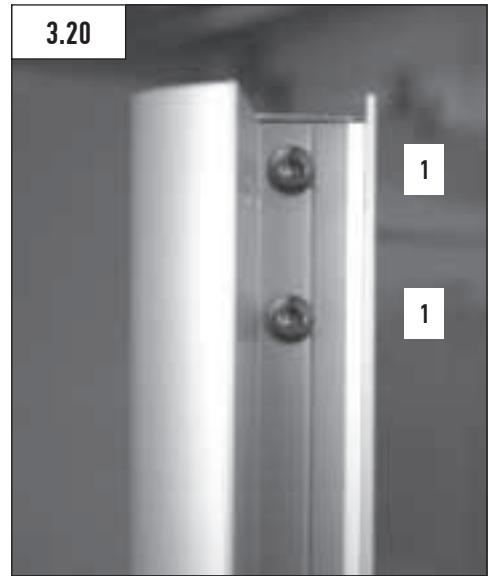
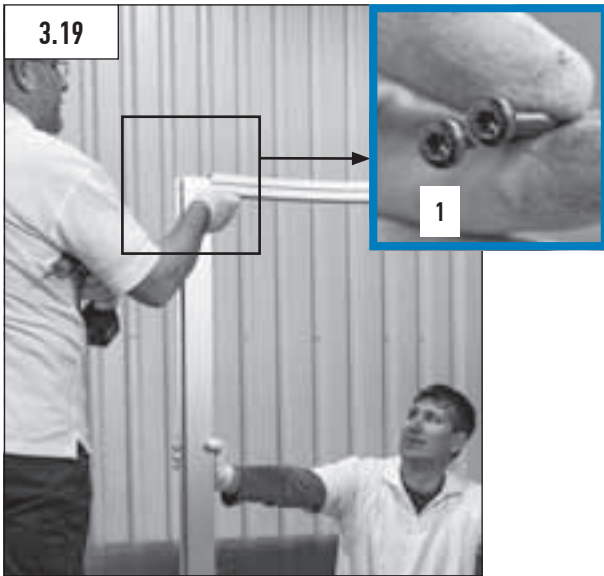

* A3, A3/4, A4S, A4L, A4, A4/5, A5 at the sliding door

**M3, M4, M4/5 M5

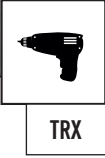

TRX



TRX



TRX

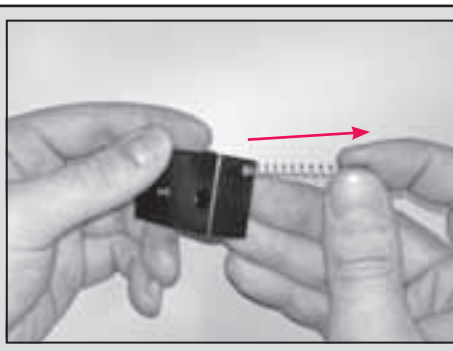
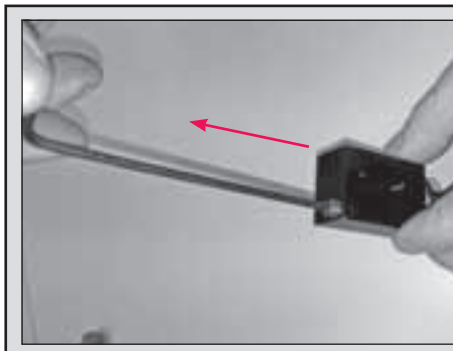

Optional:
 By removing the screw and the spring on the key lock side, the pin will arrest automatically at the right position when closing the segment.
 The opposite side should be arrested manually when closing the segment.

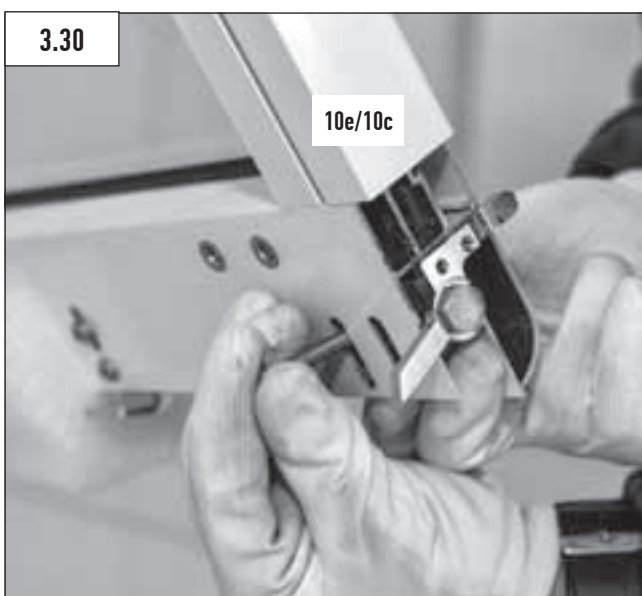
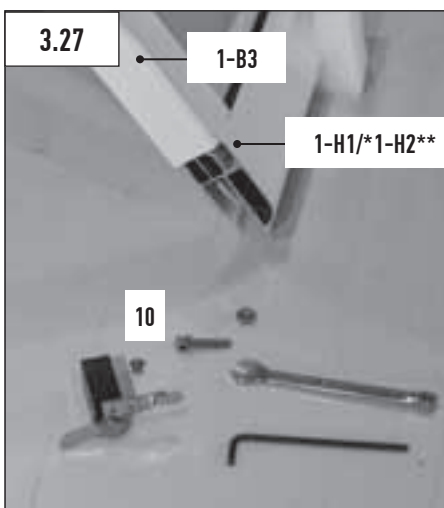

3 FIRST SEGMENT ASSEMBLY

3.32



3.33



10b

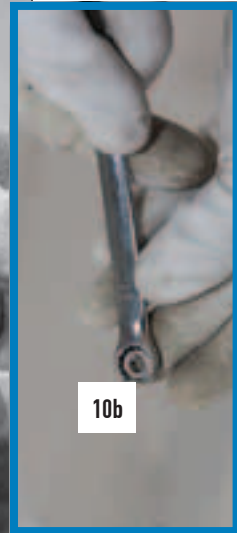

3.34

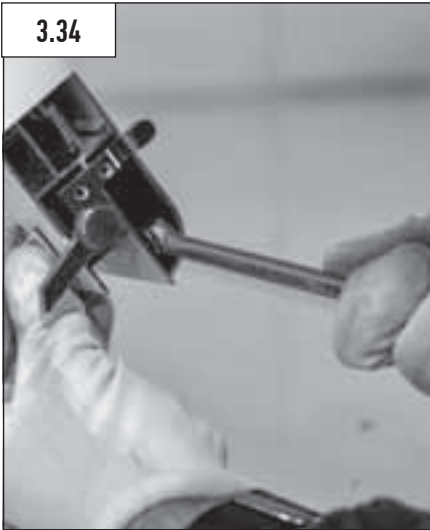

3.35

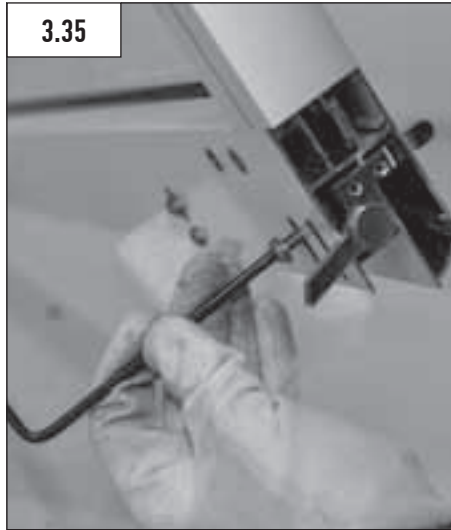

3.36

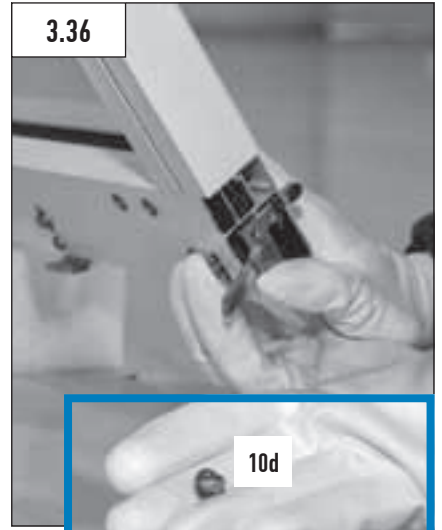

10d



3.37

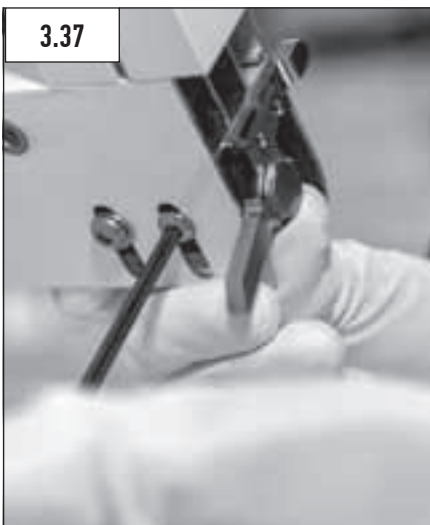

3.38

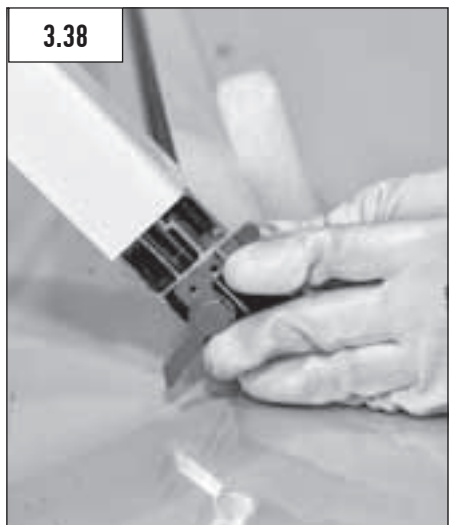

3.39

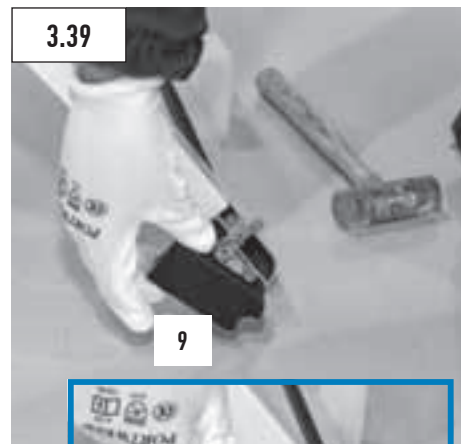

9



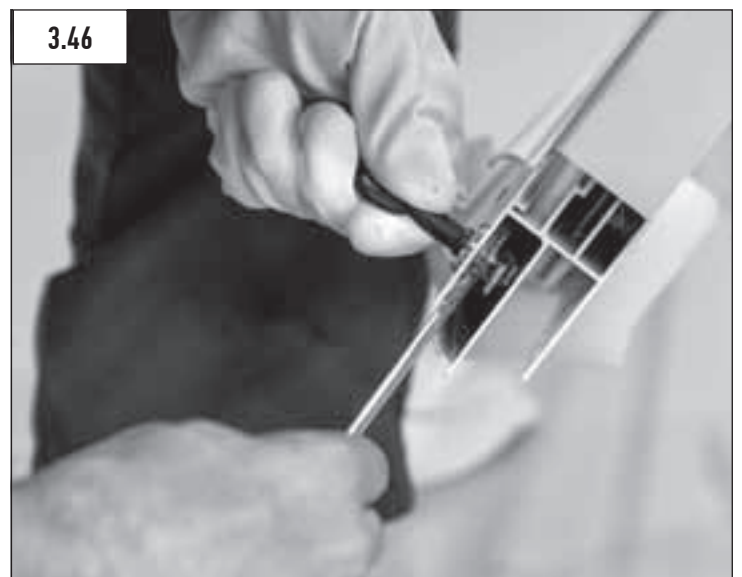
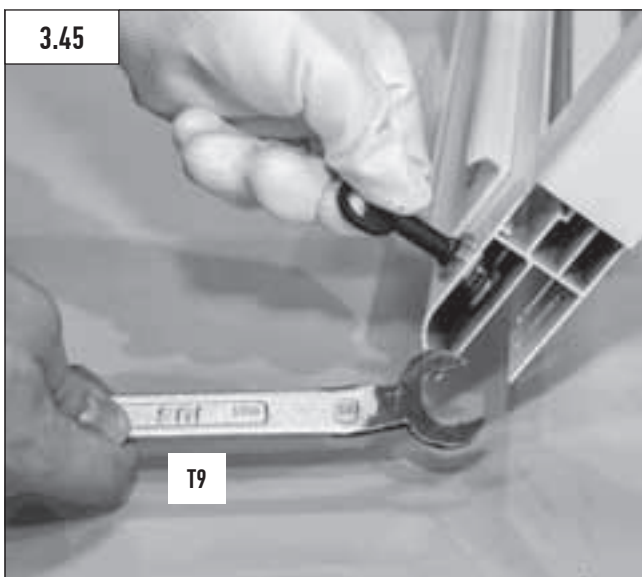
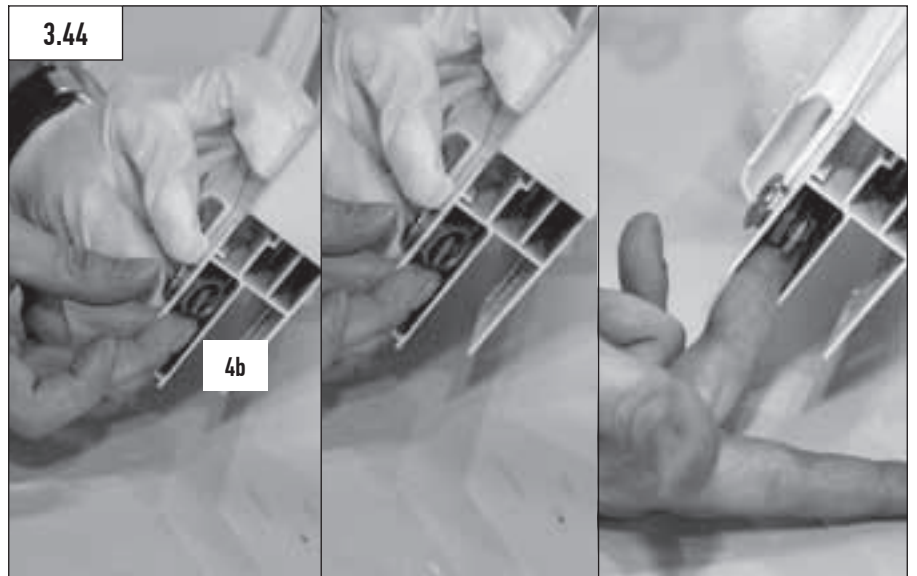
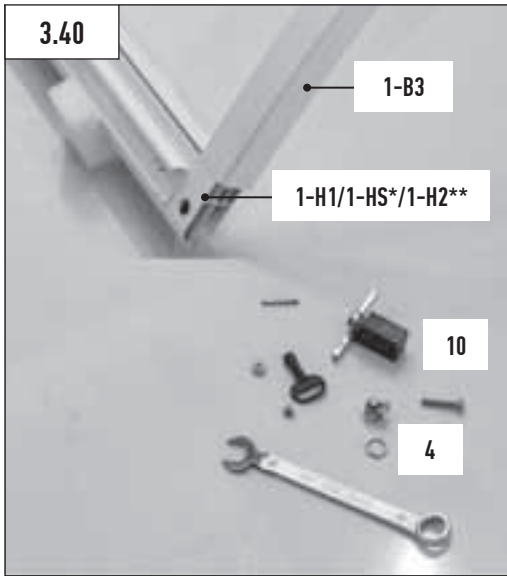

* A3, A3/4, A4S, A4L, A4, A4/5, A5 at the sliding door

**M3, M4, M4/5 M5

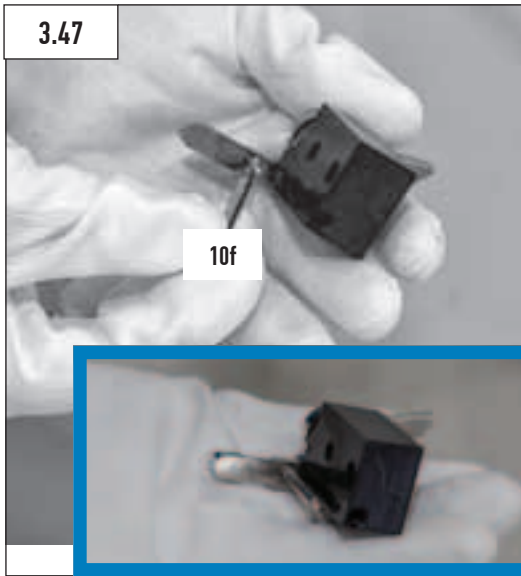

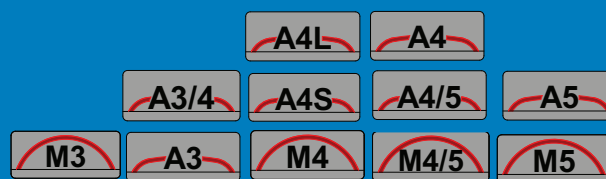
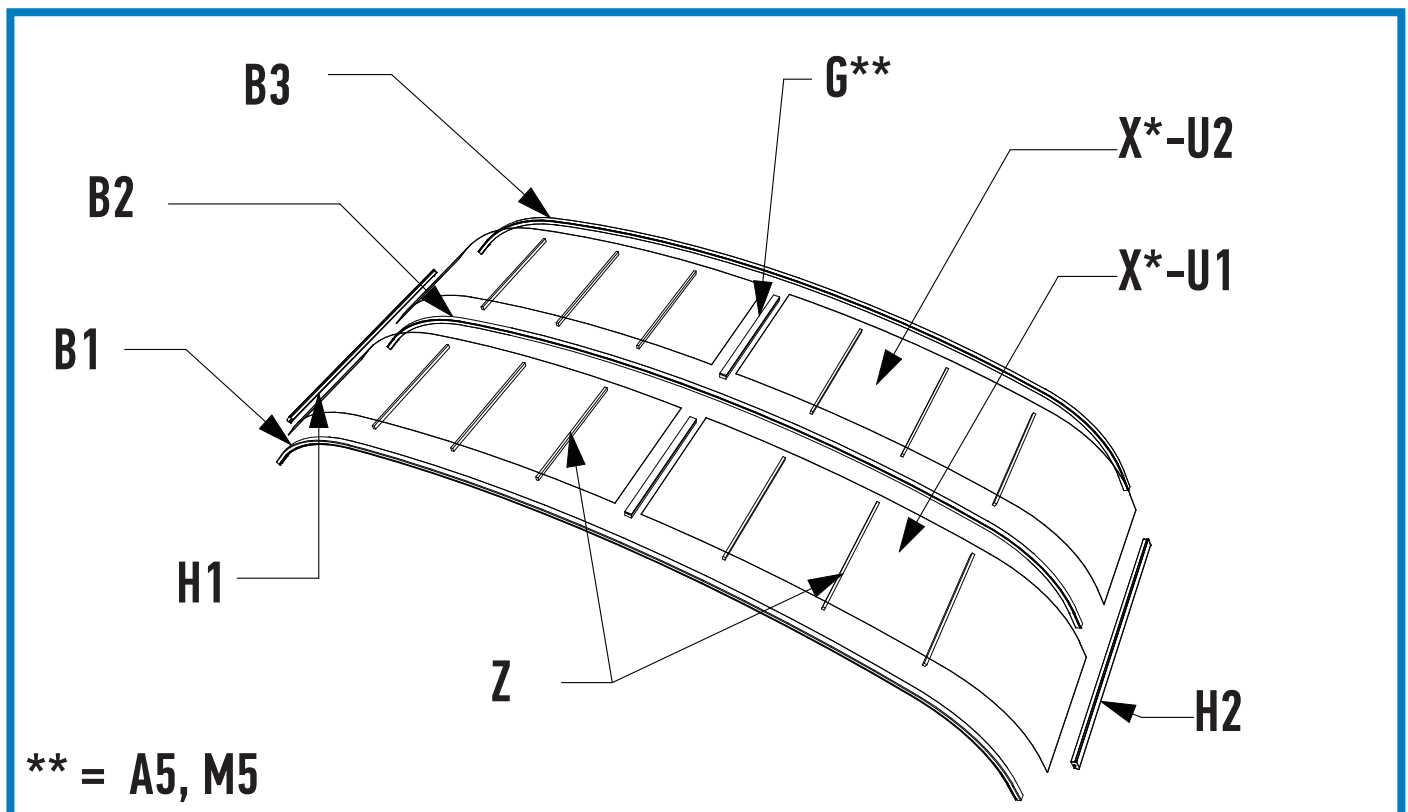

Item nr.	Item name	Pcs	Pcs	Pcs	Notes
x*-B1	1. arch	1	1	1	
x*-B2	2. arch	1	1	1	
x*-B3	3. arch	1	1	1	
H1	Receiver profile - right	1	1	1	left
H2	Receiver profile - left	1	1	1	right
X*-U1	PC Clear plate / PC Thermo plate	1	1	2	
X*-U2	PC Clear plate / PC Thermo plate	1	1	2	
Z	Linking hollow section	8	10	10	
G	Linking profile	-	-	2	
1	Pen head torx screw	12	12	12	4,8 x 50
12	Rocker lever	1	1	1	1
18	Buffer plate	1	1	1	1 left + 1 right
9	Receiver profile cap	1	1	1	1 left + 1 right
11	Receiver profile cap	1	1	1	1 left + 1 right
22	Outside rubber (double)***				

*** with PC Clear plate

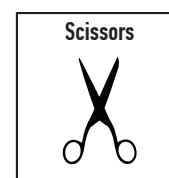
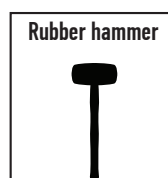
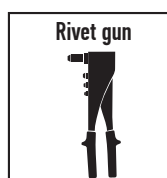

4 INTERMEDIATE SEGMENT ASSEMBLY

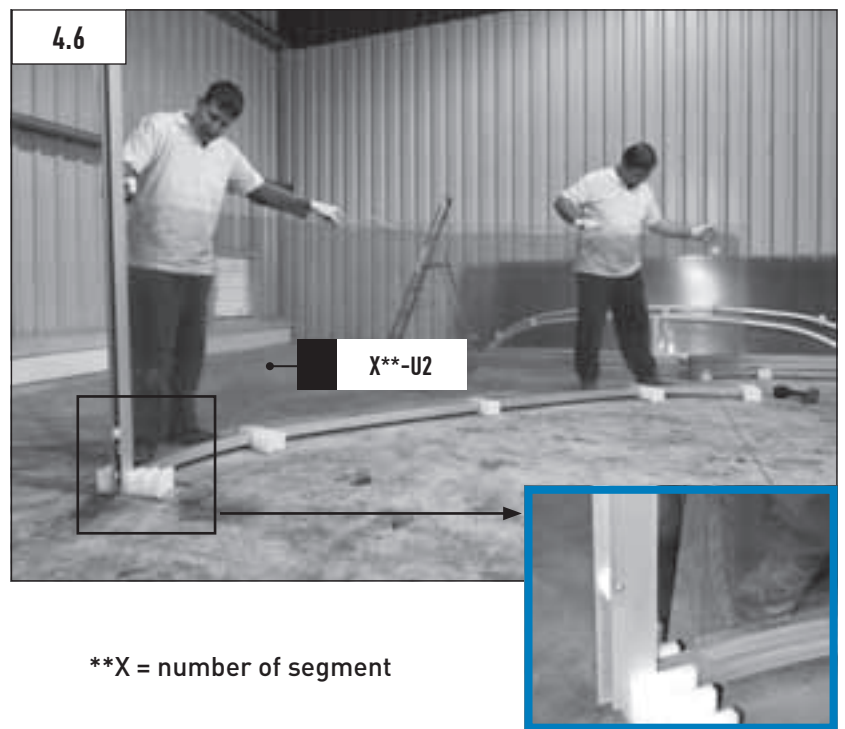
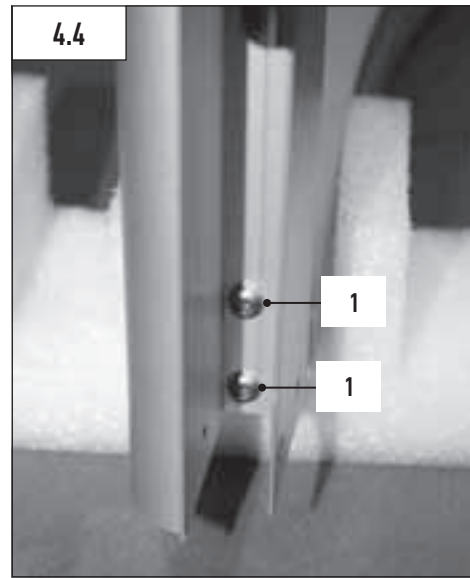
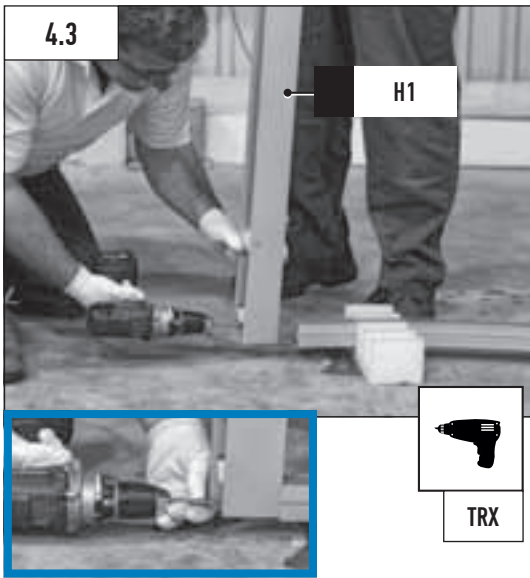
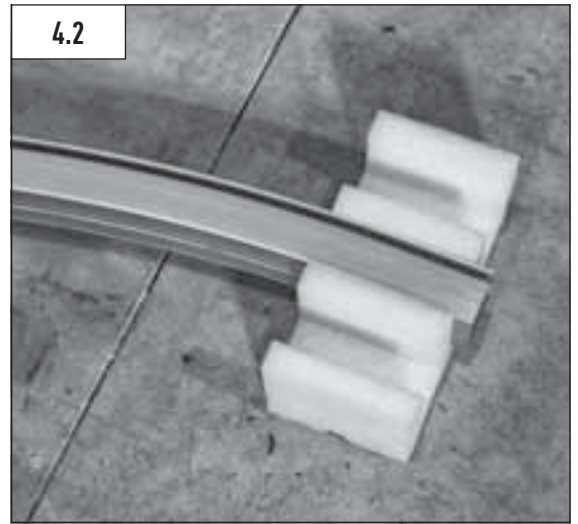
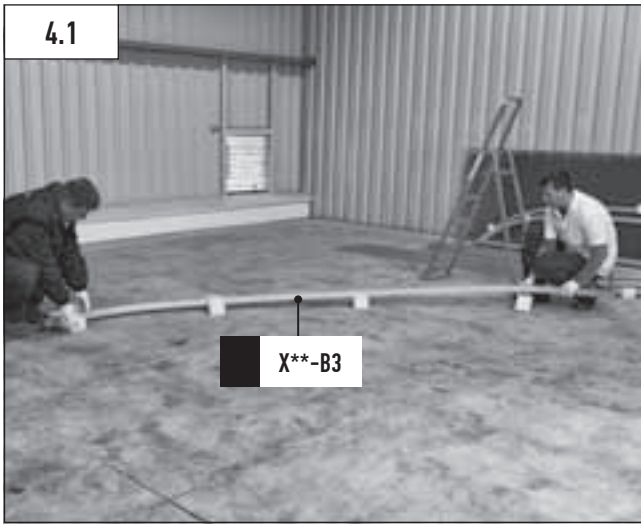

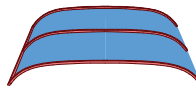
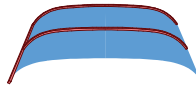
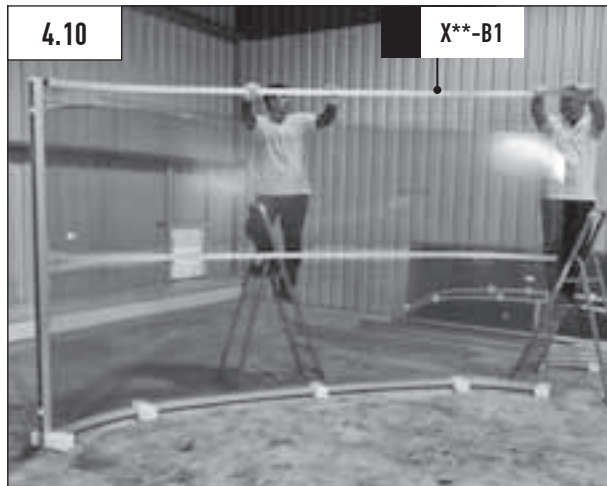
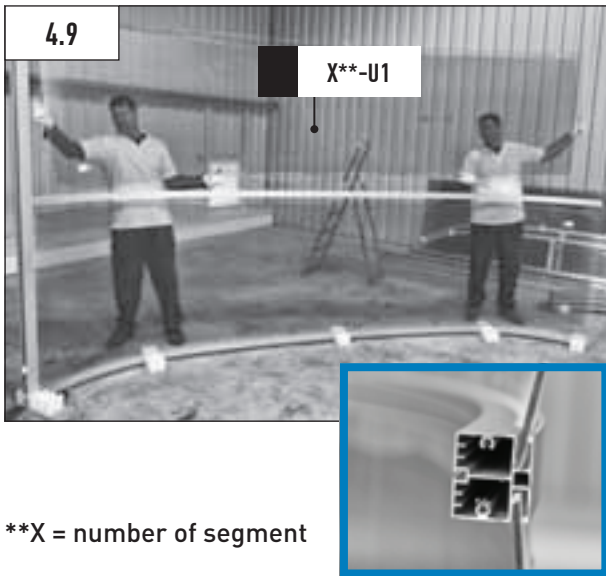
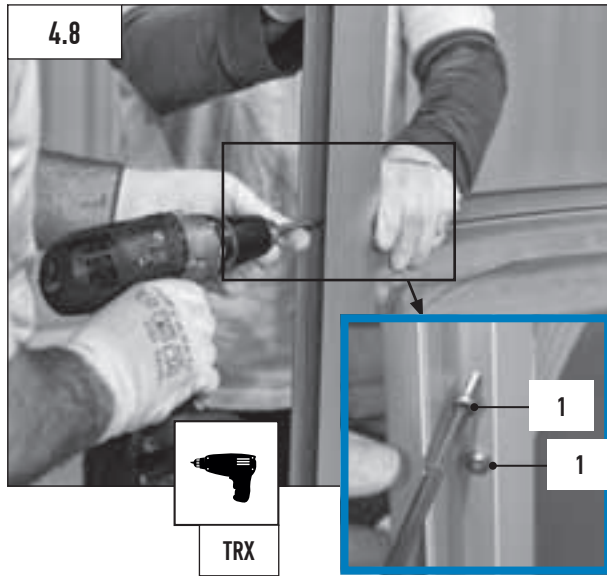
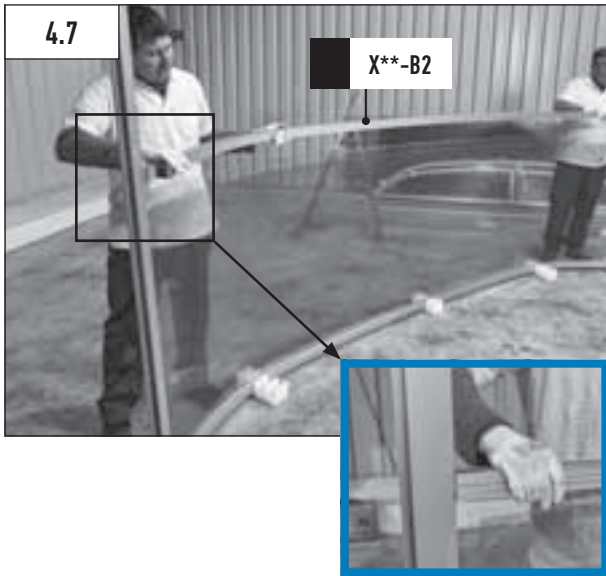

**X = number of segment

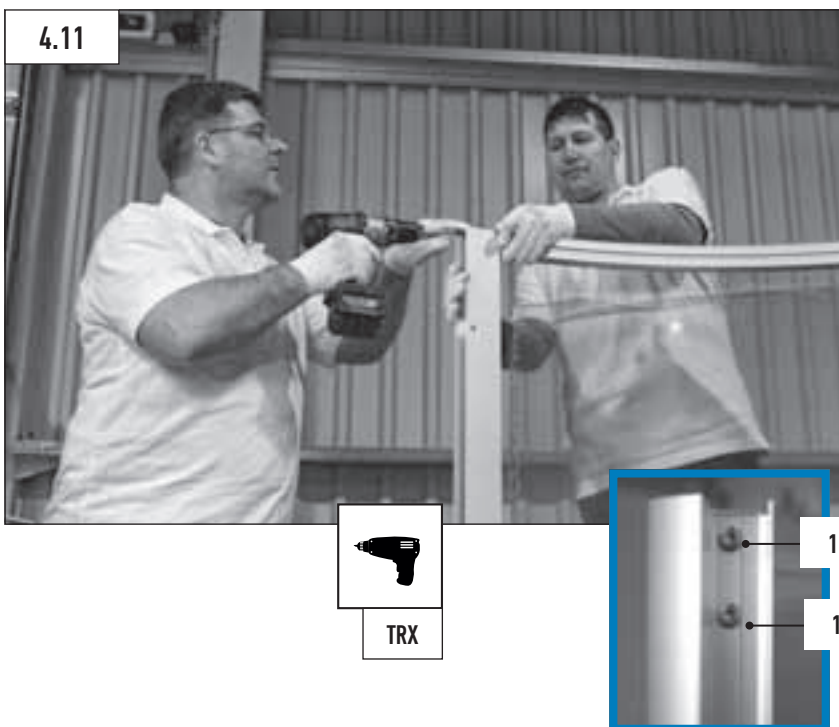

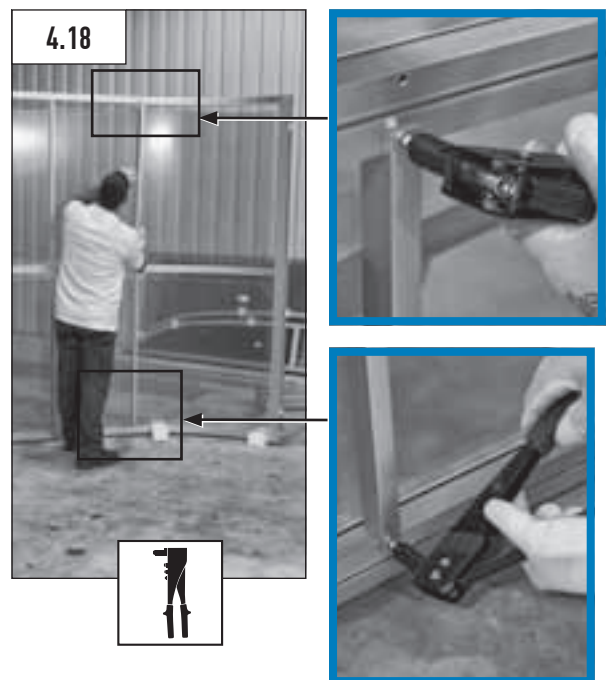
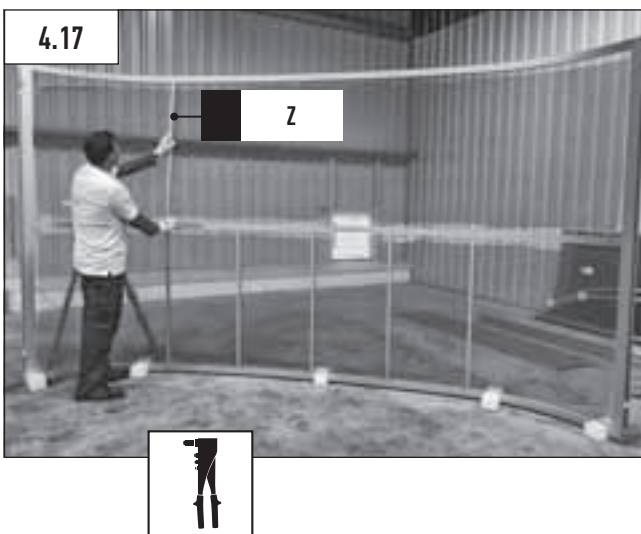
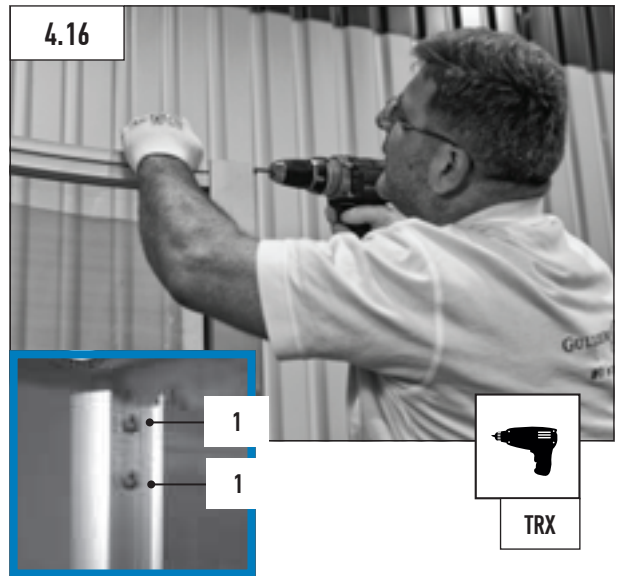
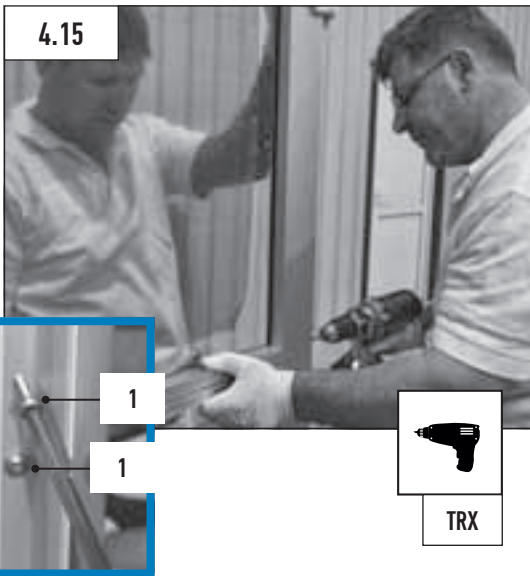
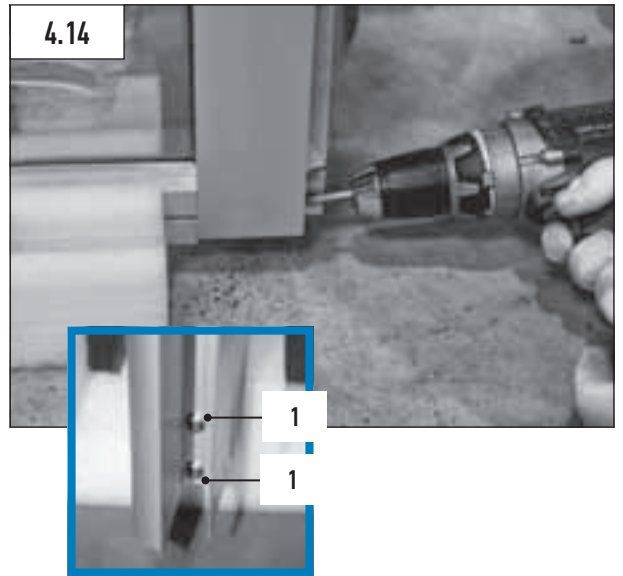
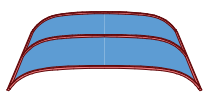

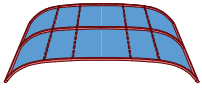

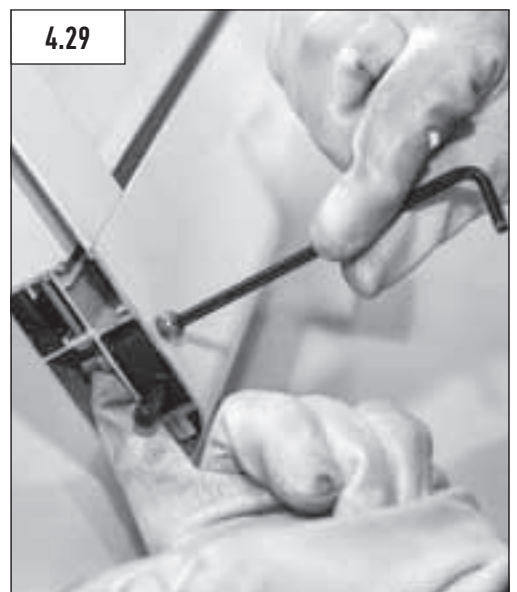
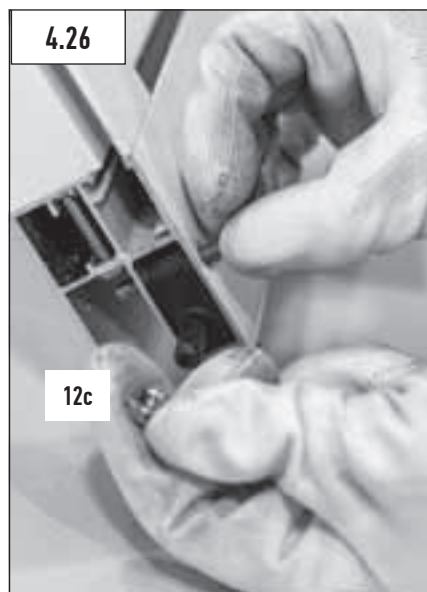
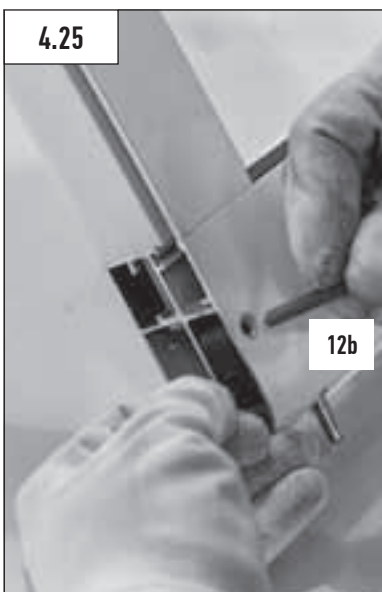
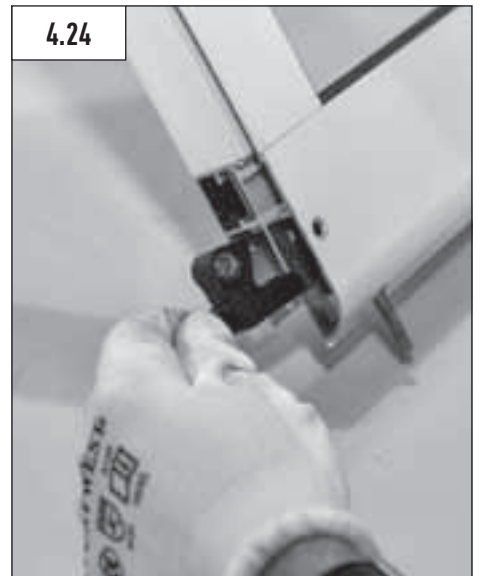
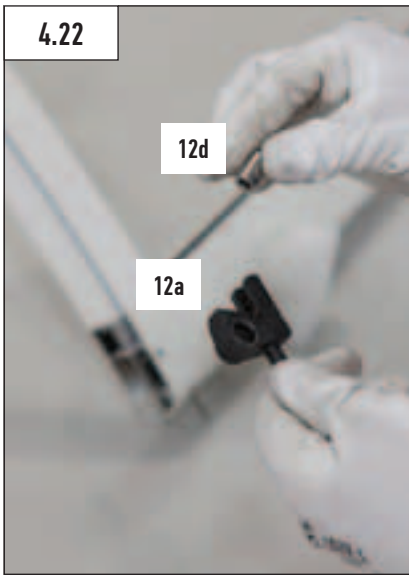
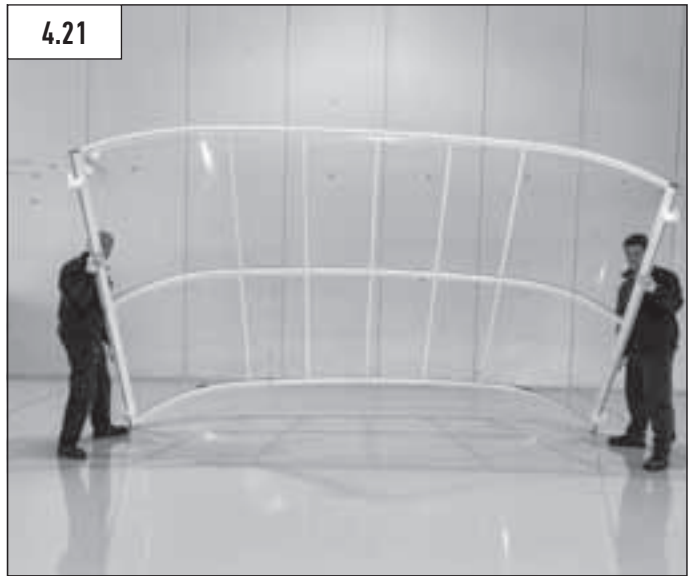
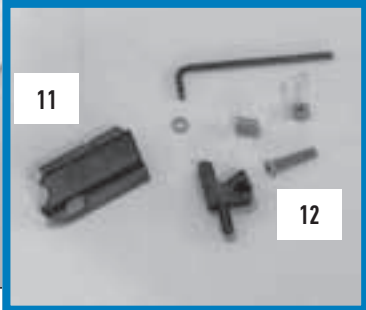

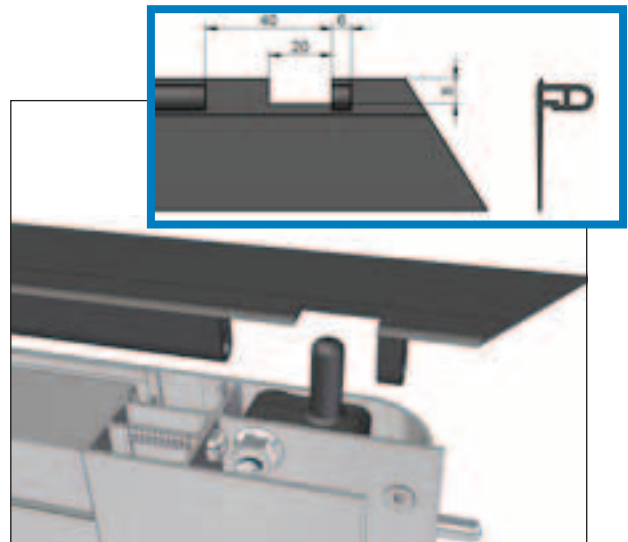
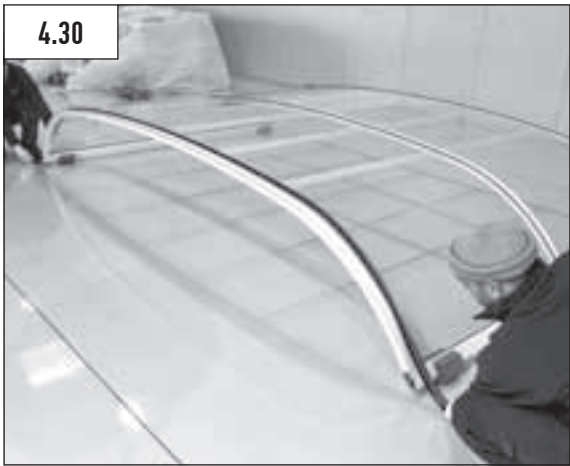

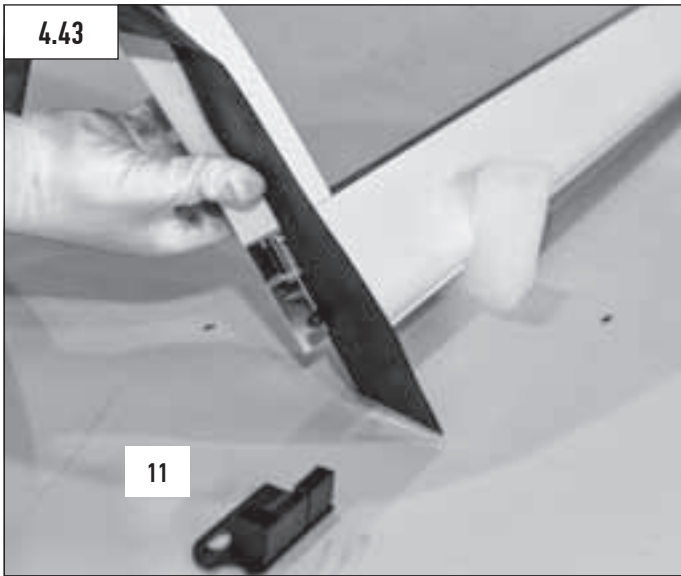

**Repeat steps 4.1 - 4.49
(see at page 30-36)**

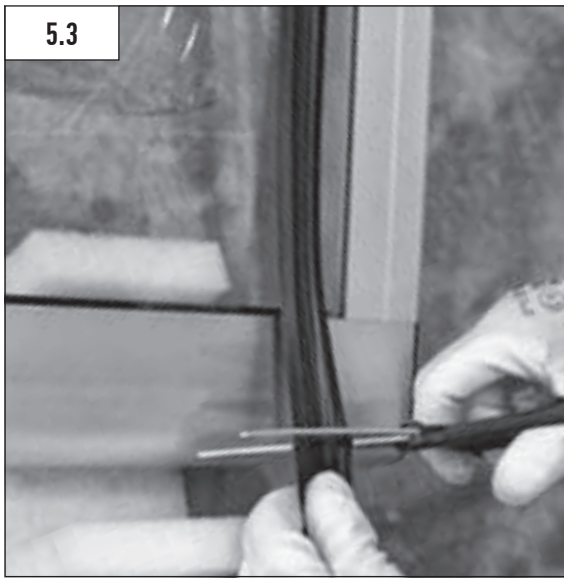

5 SEGMENT RUBBER SEAL INSTALLATION



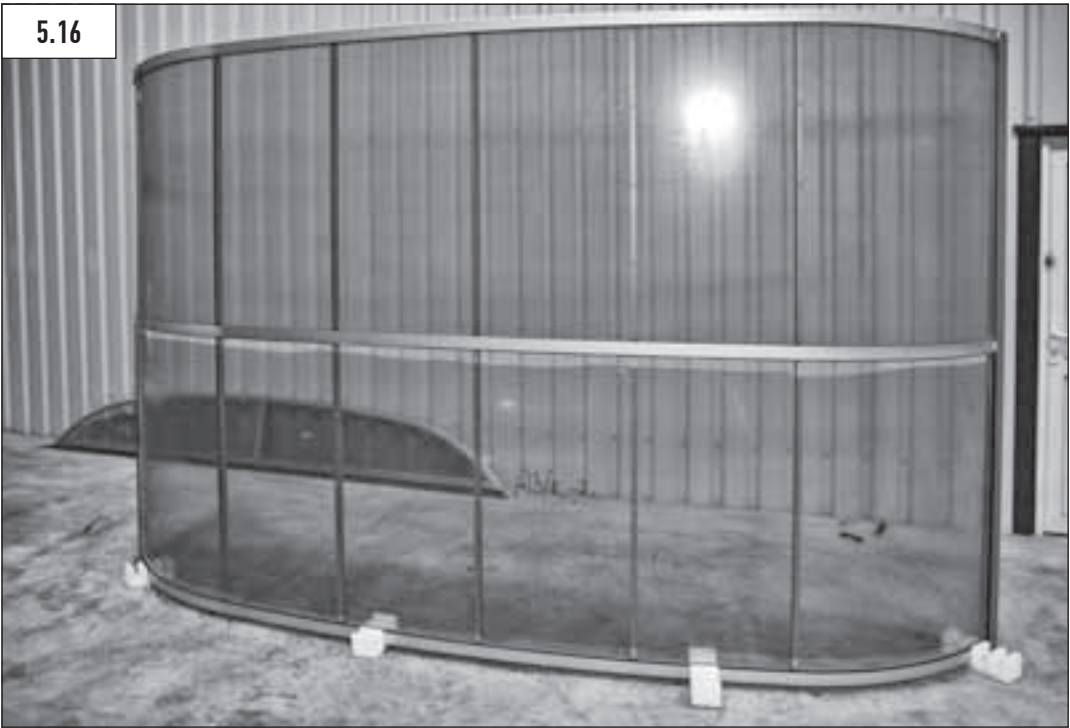

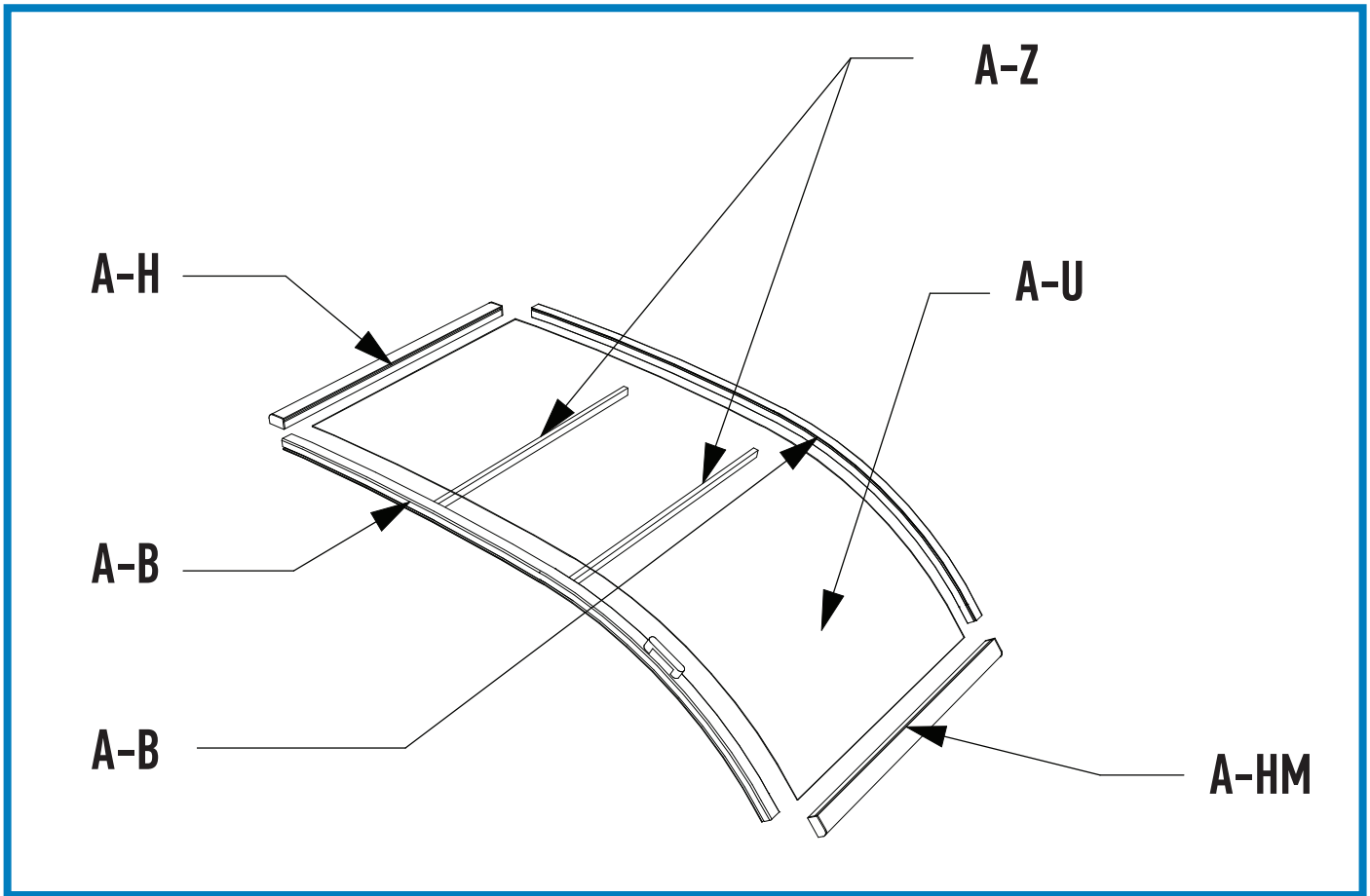

Item nr.	Item name	Pcs		Notes
A-B	1. arch	1	1	
A-B	2. arch	1	1	
A-H	Receiver profile	1	1	
A-HM	Receiver profile marked	1	1	
A-U	PC Clear plate / PC Thermo plate	1	1	
A-Z	Linking hollow section	2	3	
1	Pen head torx screw	8	8	
15a	Sliding door lock	1	1	
15b	Sliding door plug	1	1	
17	Plastic plug	8	8	
21	Sliding door bottom rubber	1	-	
22	Outside rubber (double)*			

*With PC Clear plate

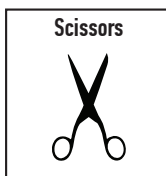

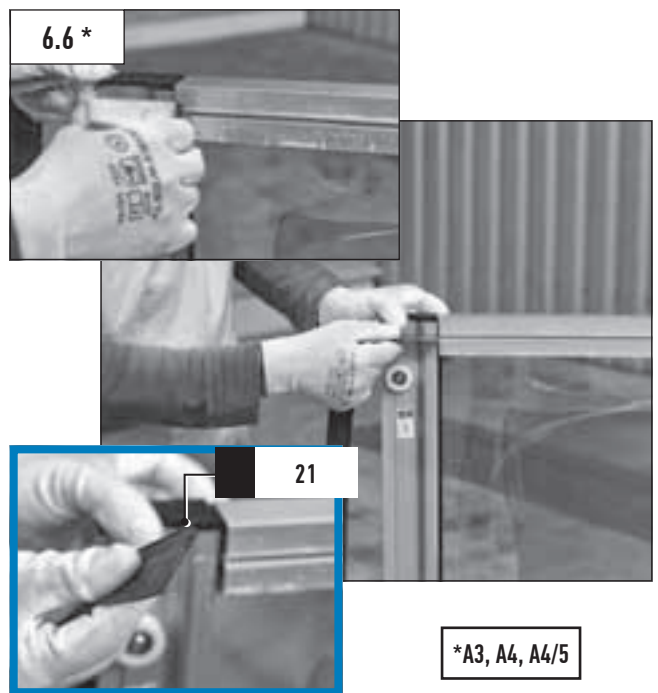
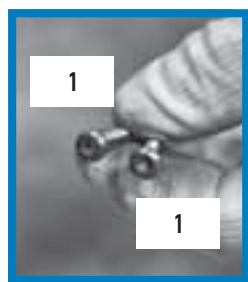
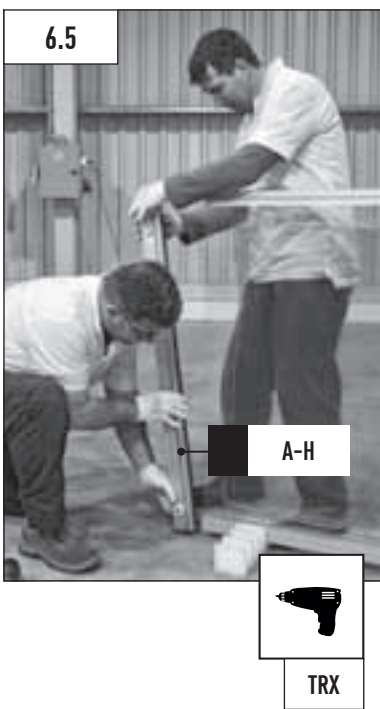
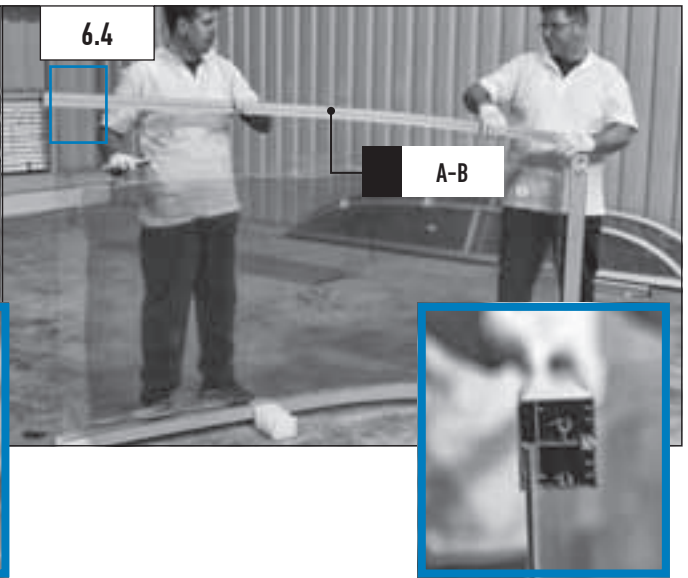
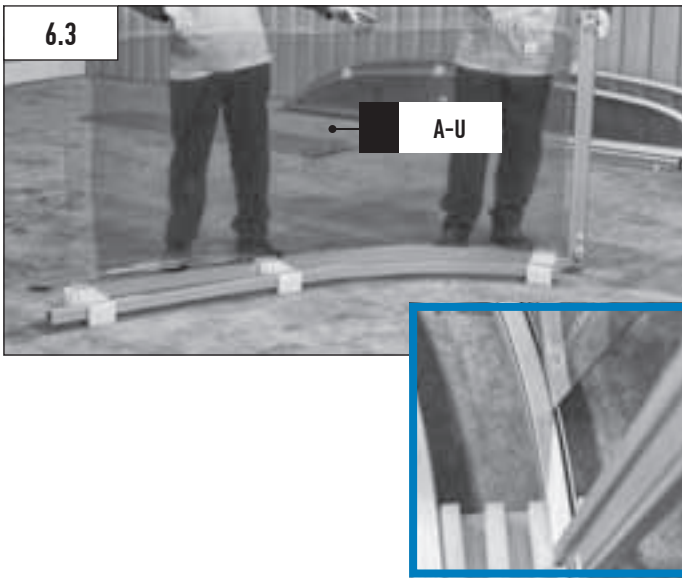
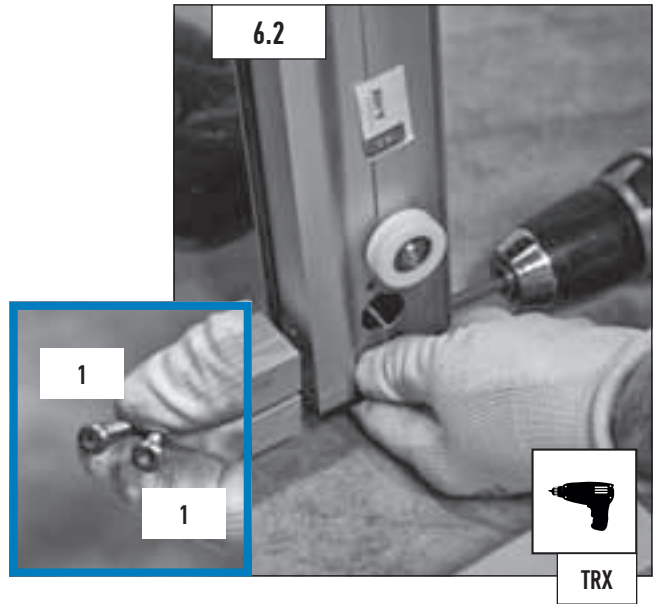
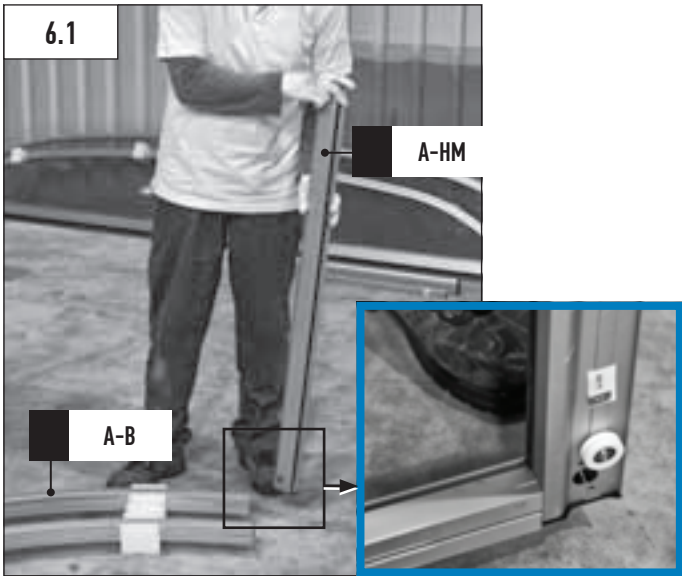

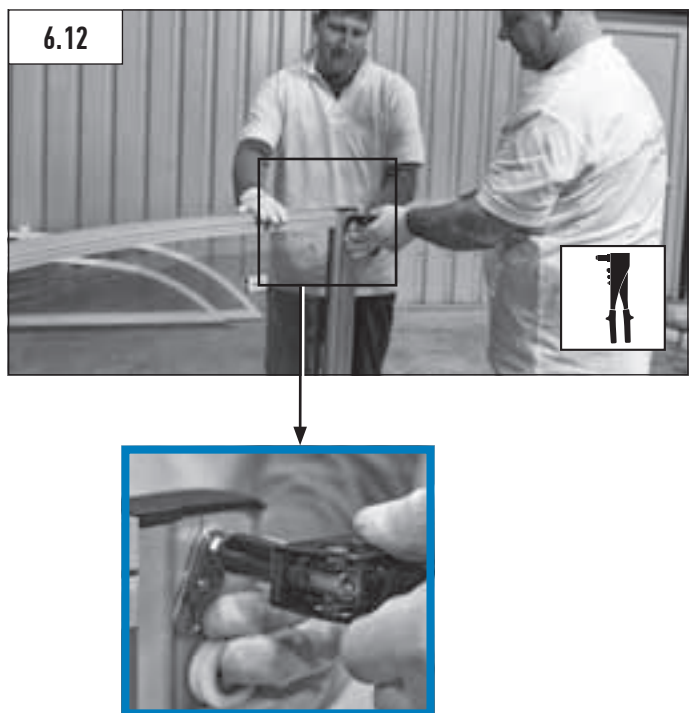
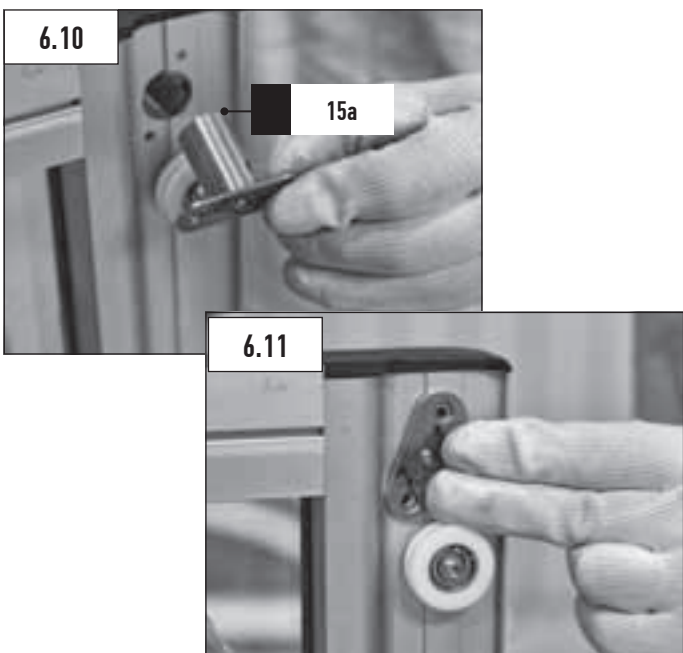
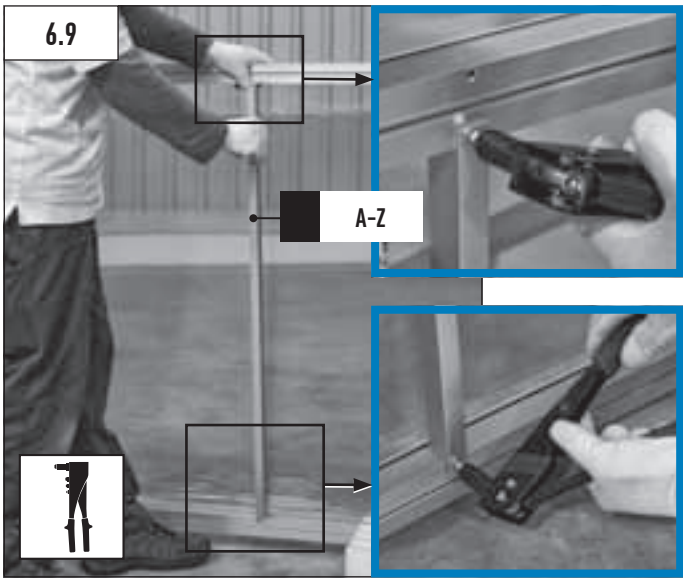
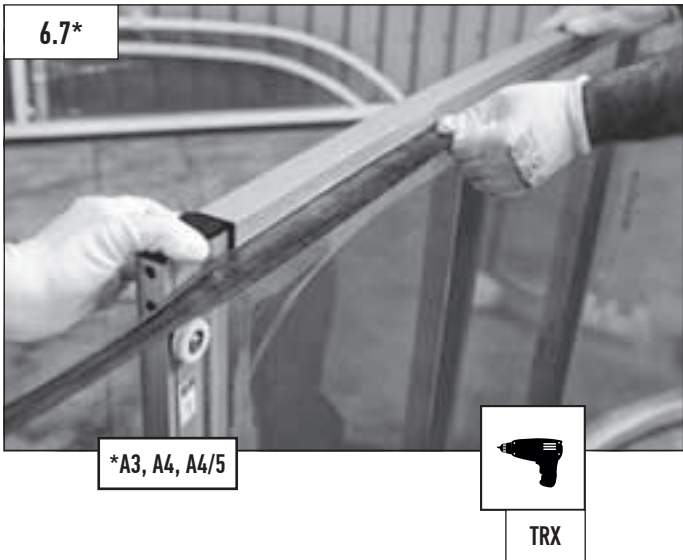

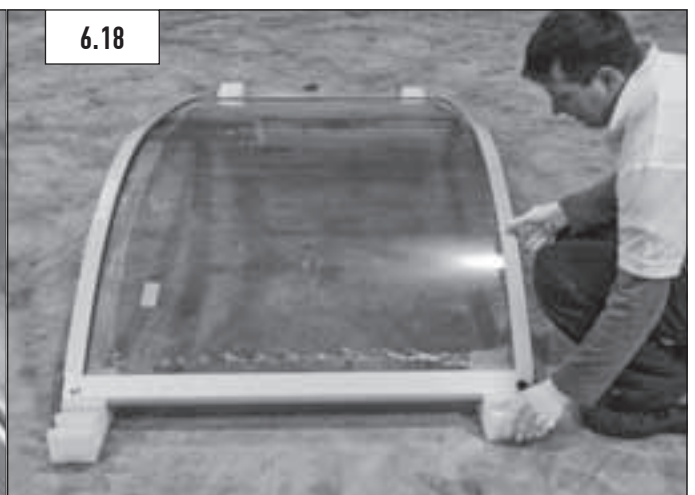
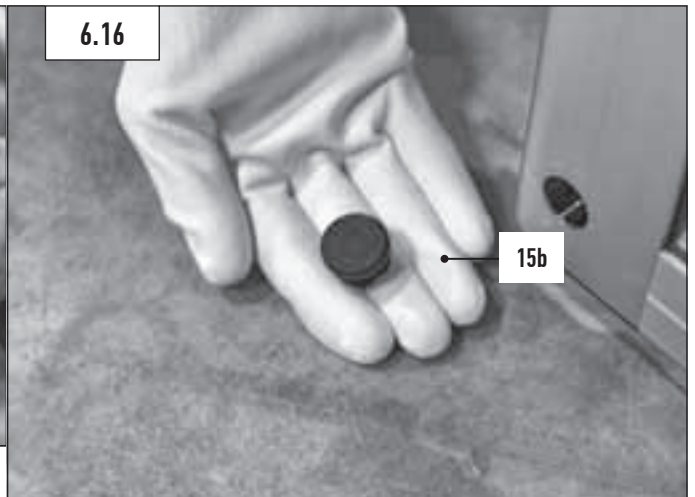
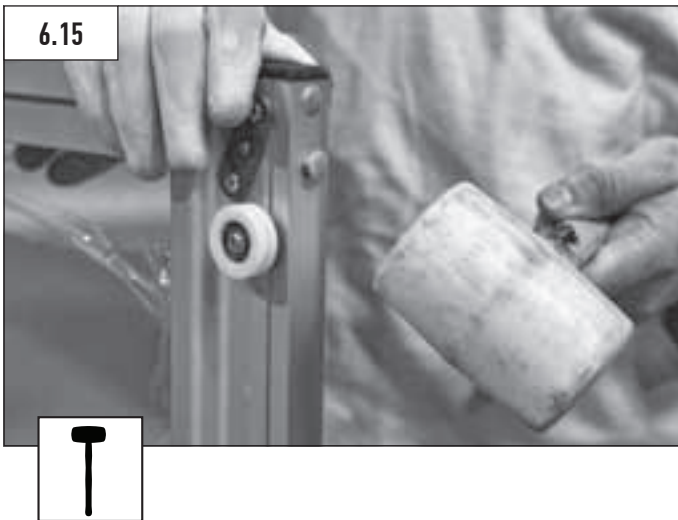
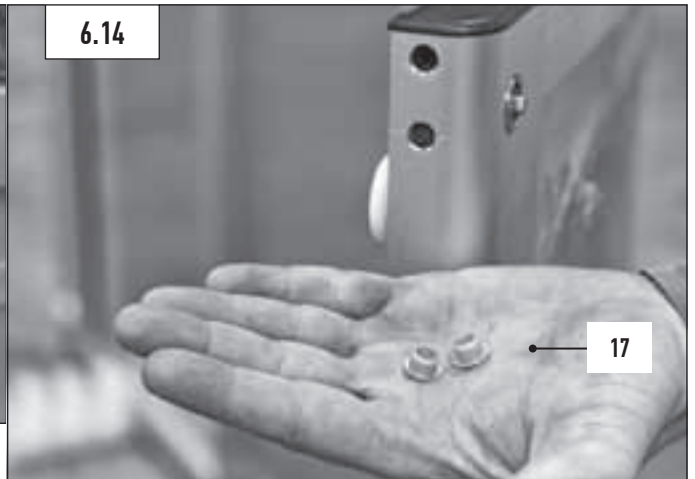

6 SLIDING DOOR RUBBER SEAL INSTALLATION (NEXT TO THE PC CLEAR PLATE)

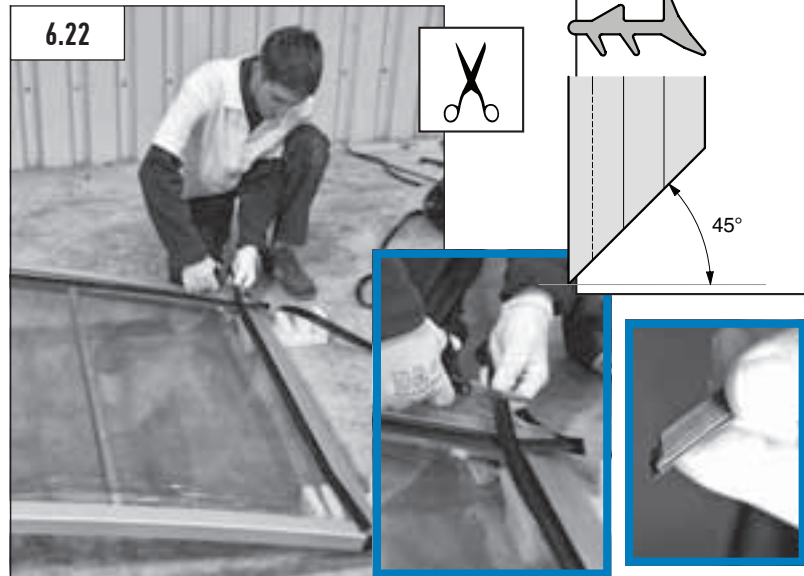
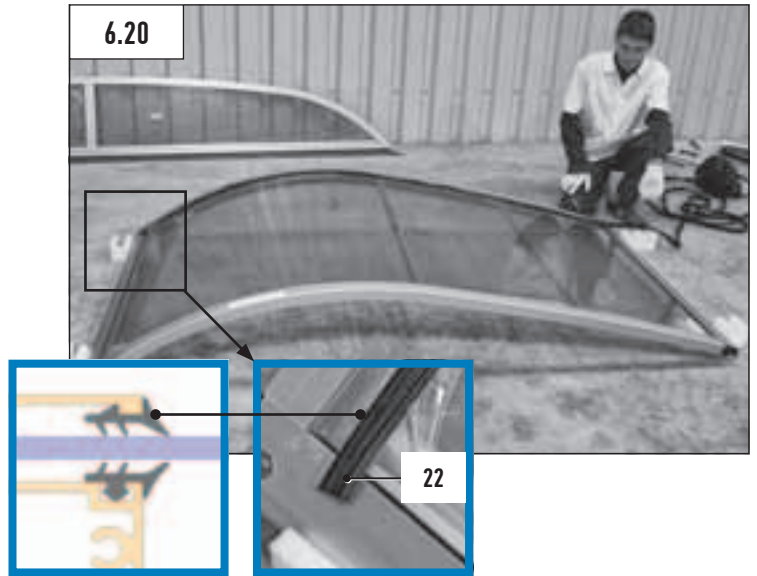

6 SLIDING DOOR RUBBER SEAL INSTALLATION (NEXT TO THE PC CLEAR PLATE)

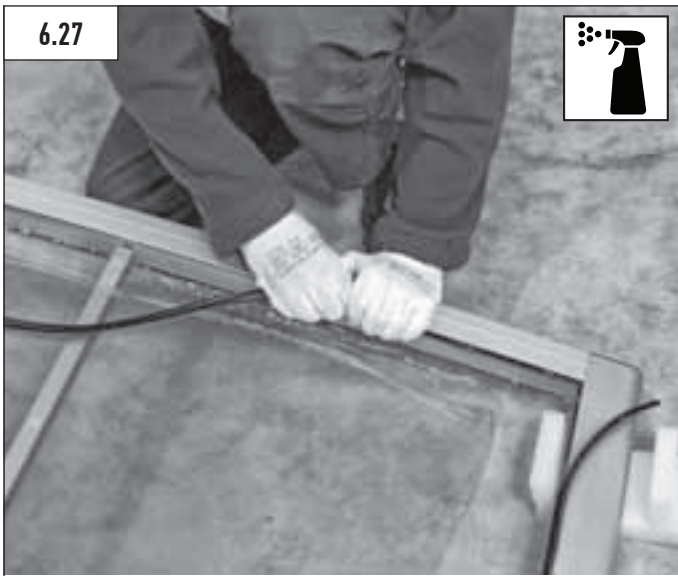
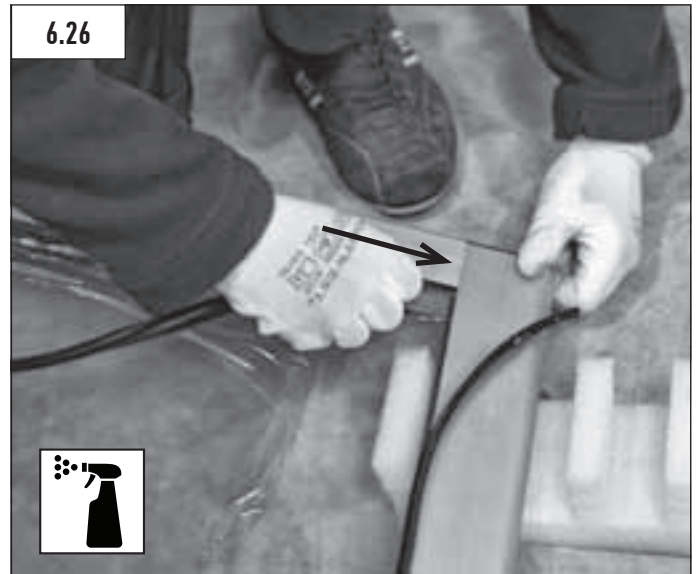
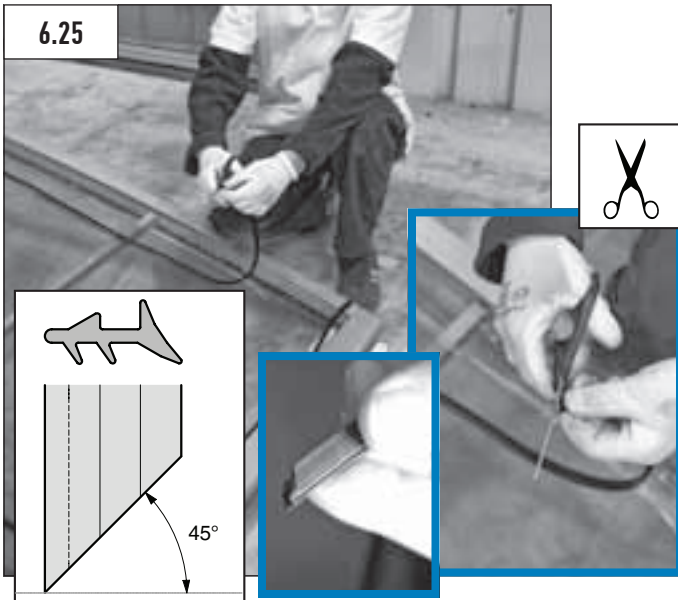

6 SLIDING DOOR RUBBER SEAL INSTALLATION (NEXT TO THE PC CLEAR PLATE)

6.31



6.32



6.33

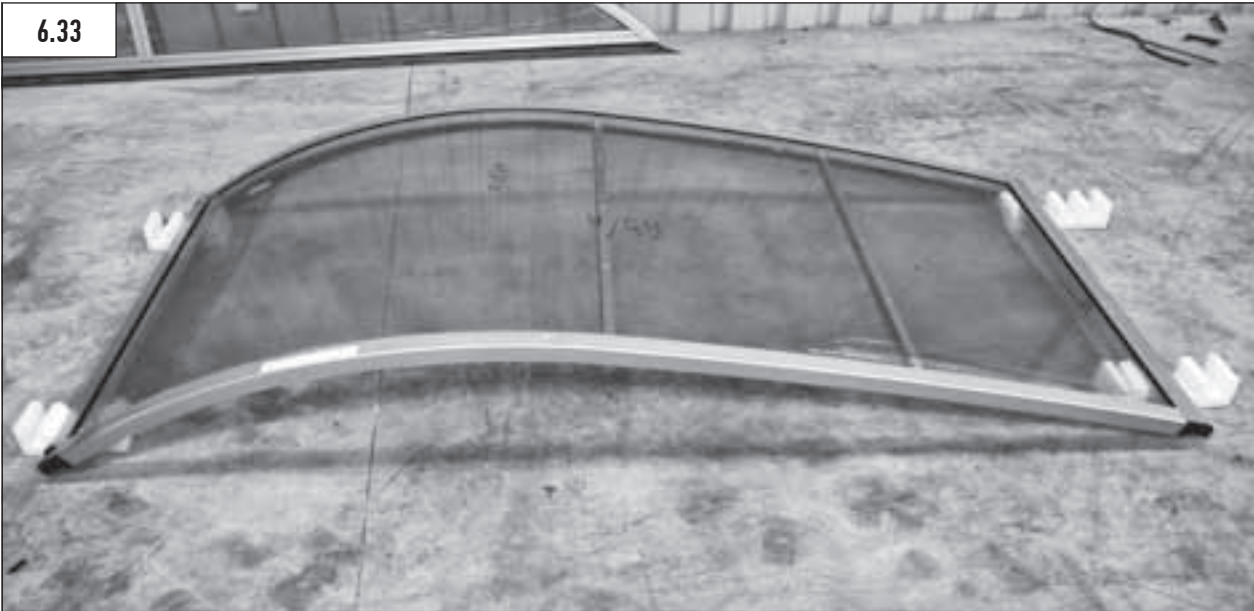

7 MOUNTING SEGMENTS ONTO RAILS

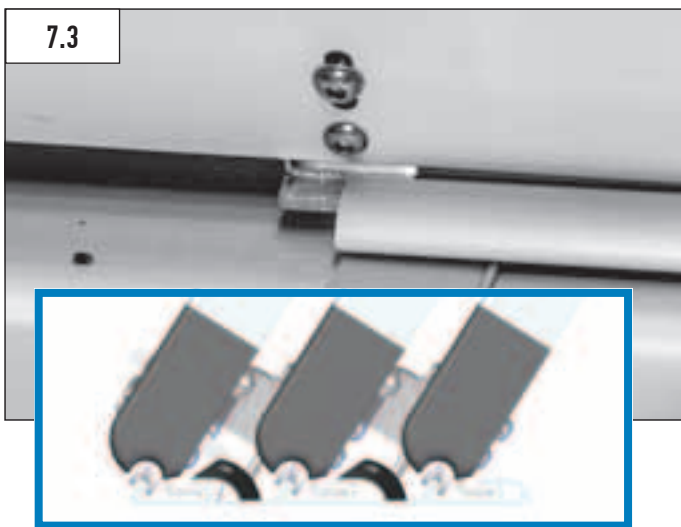



8 END WALL INSTALLATION - FIRST SEGMENT

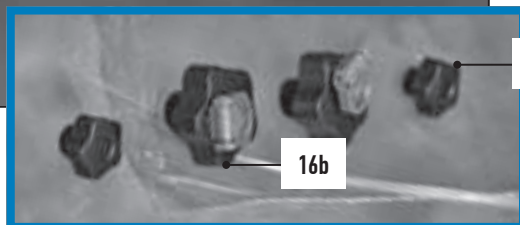
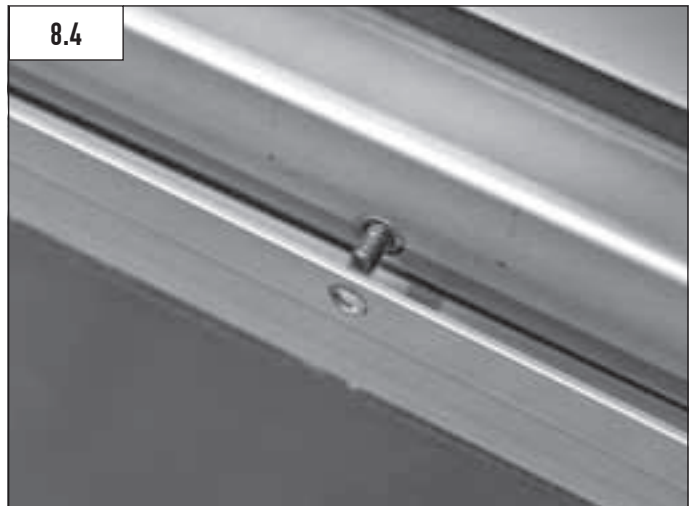

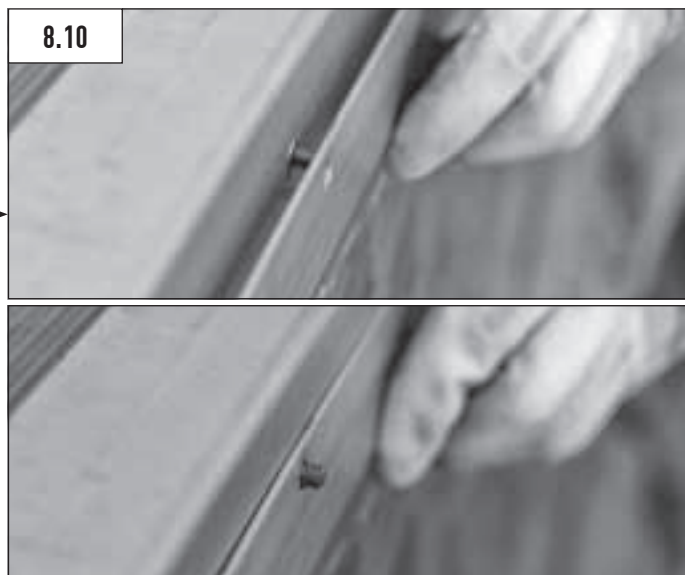
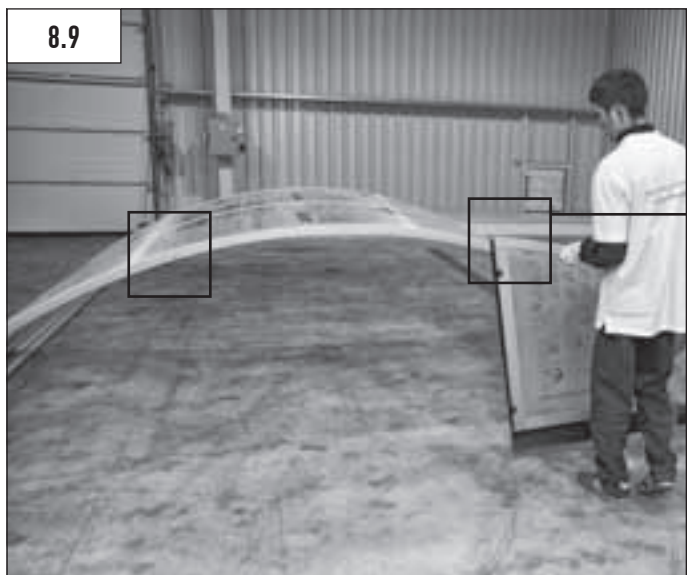

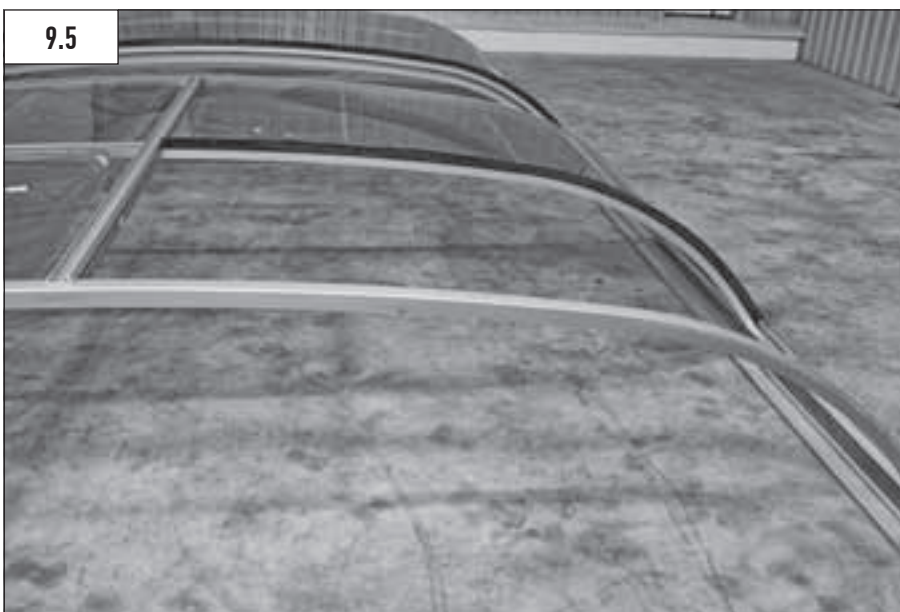
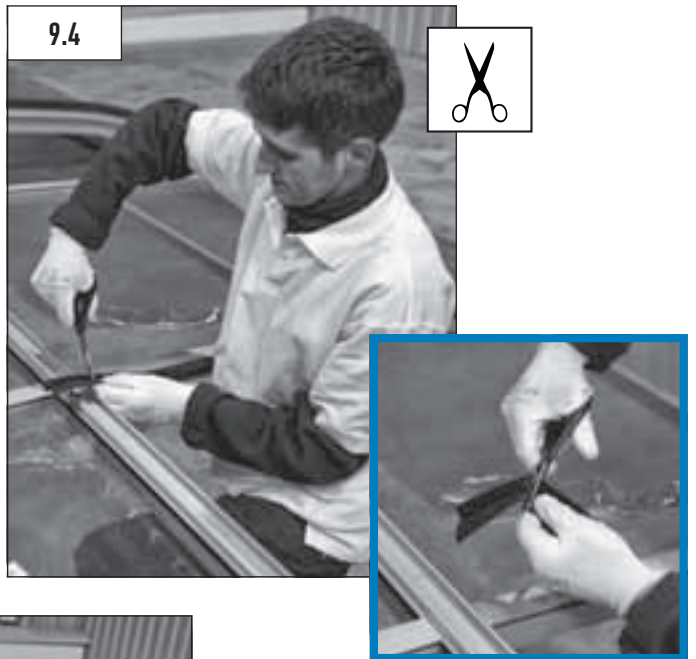
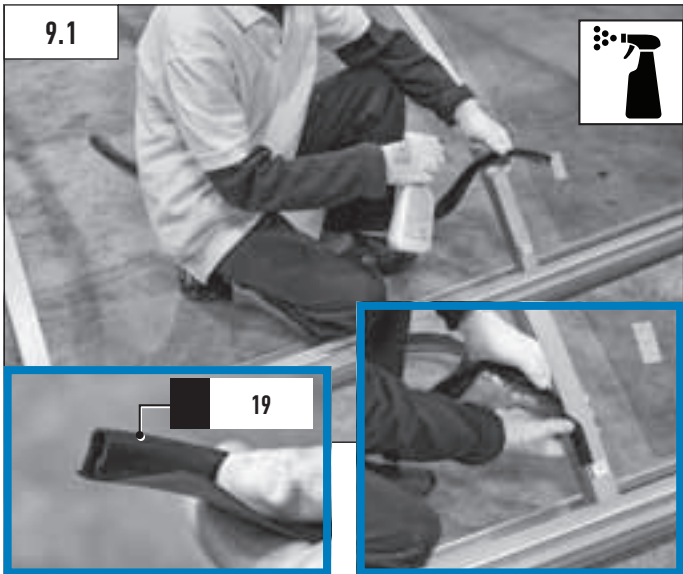

with A3 - A3/4 - A4S - A4L - A4 - A4/5 models

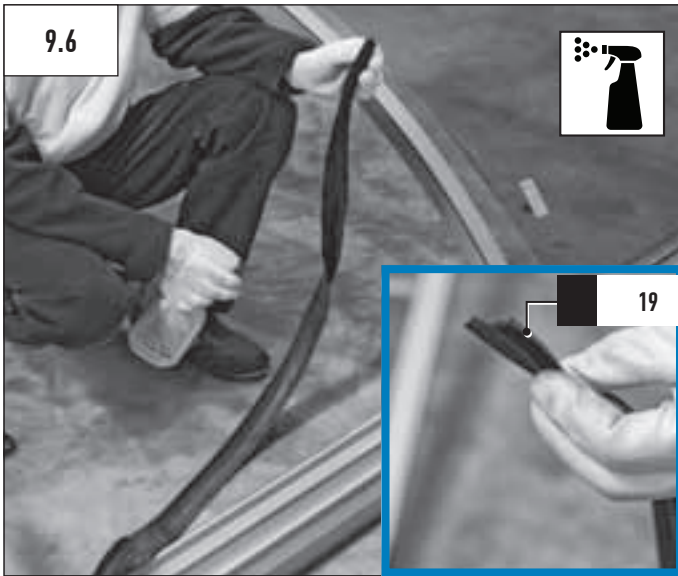



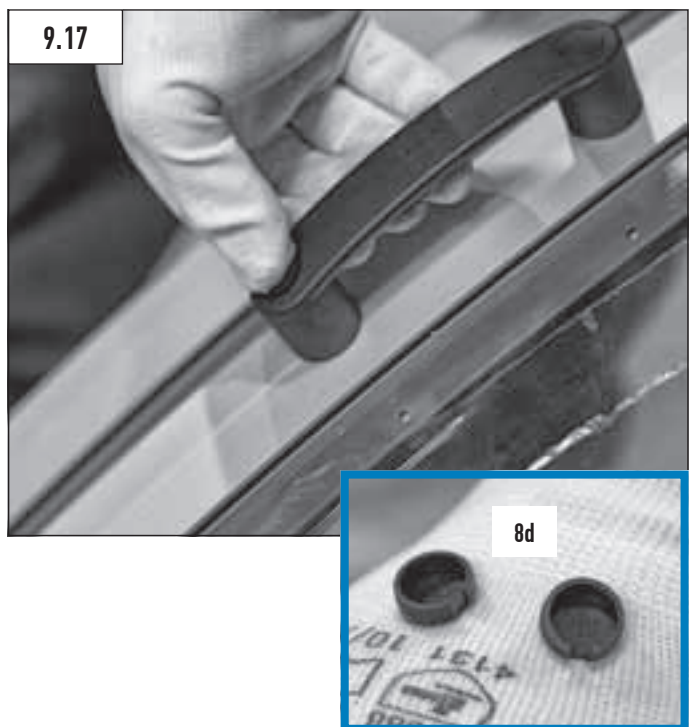
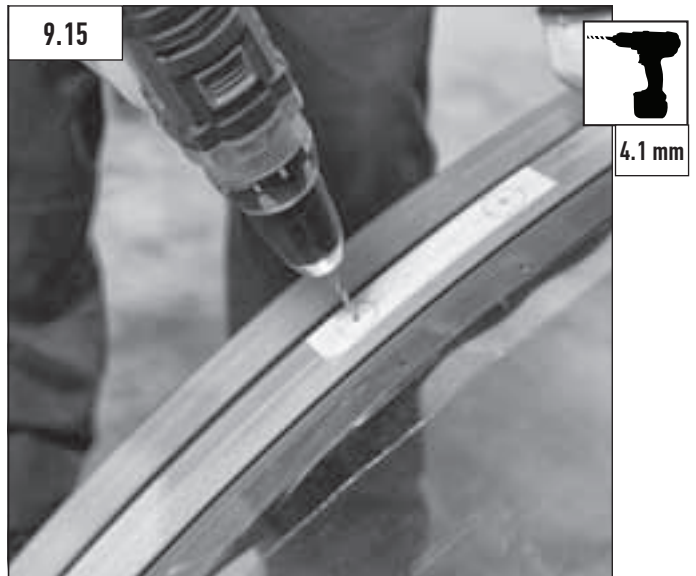
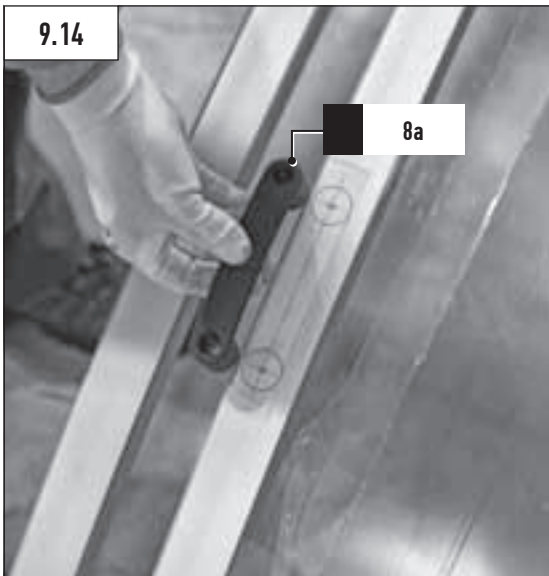
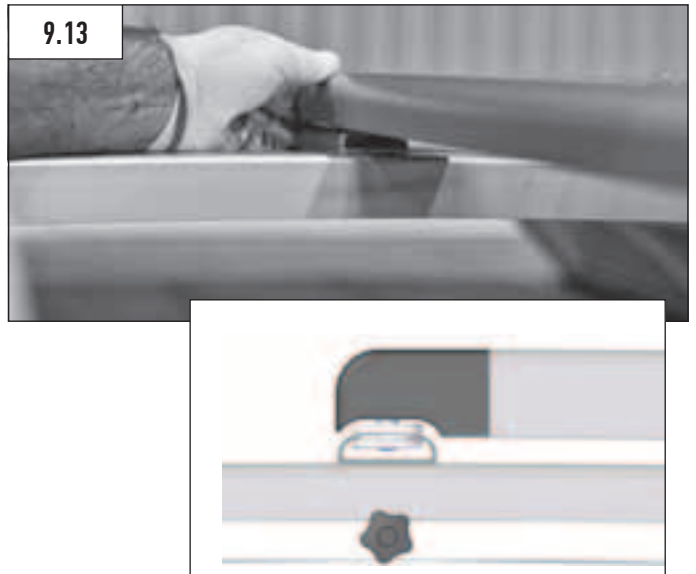

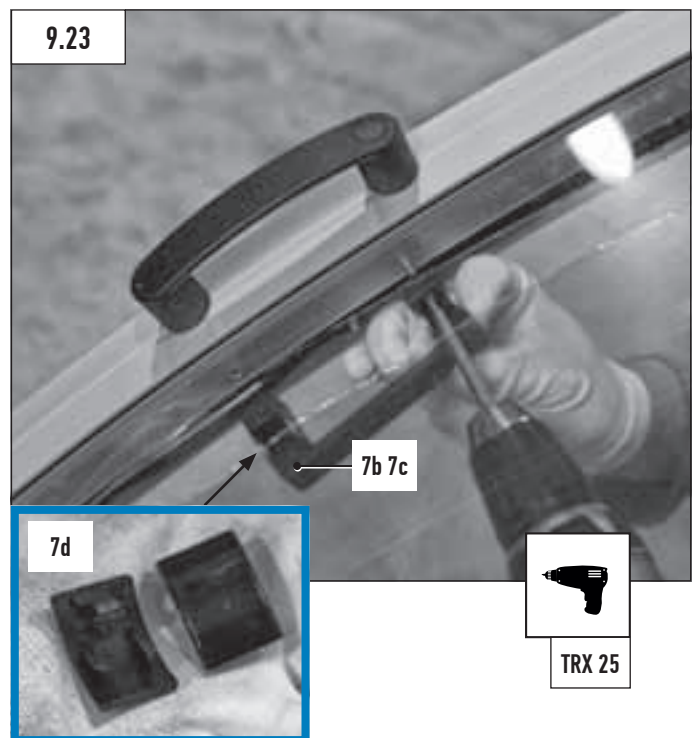
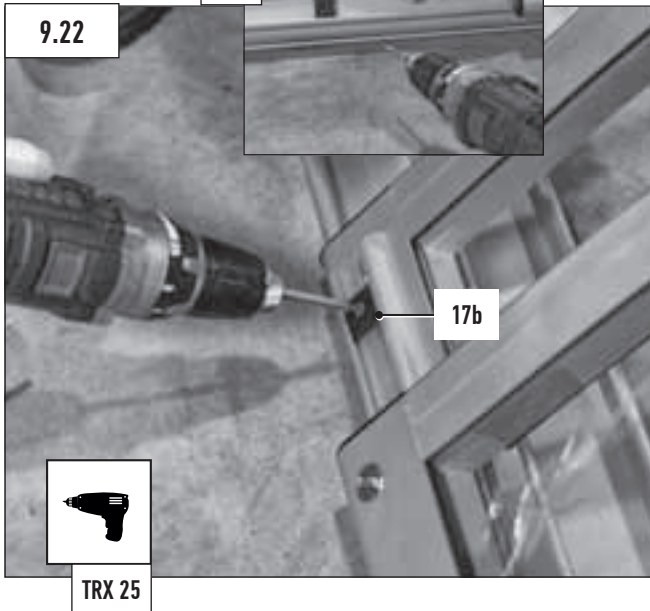
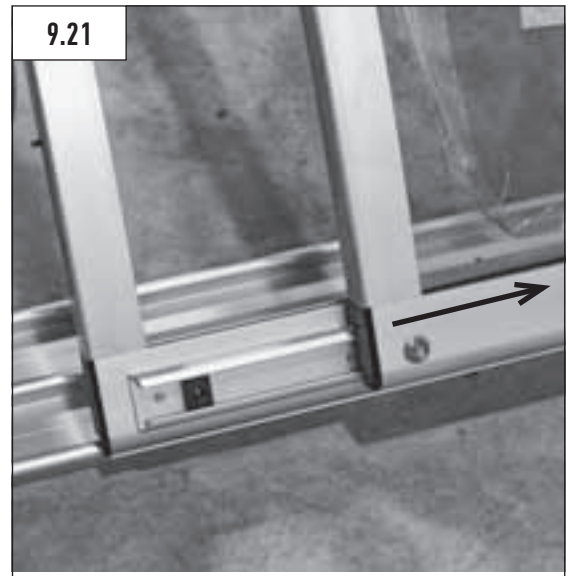
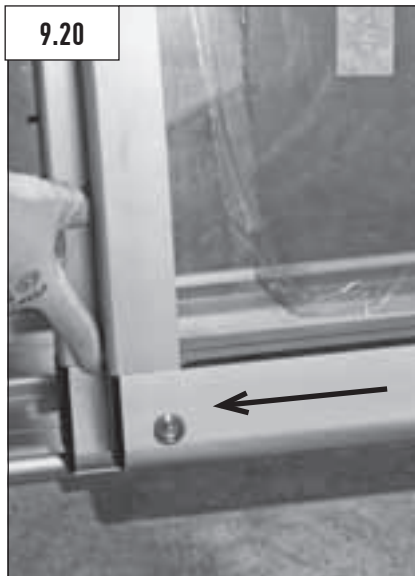
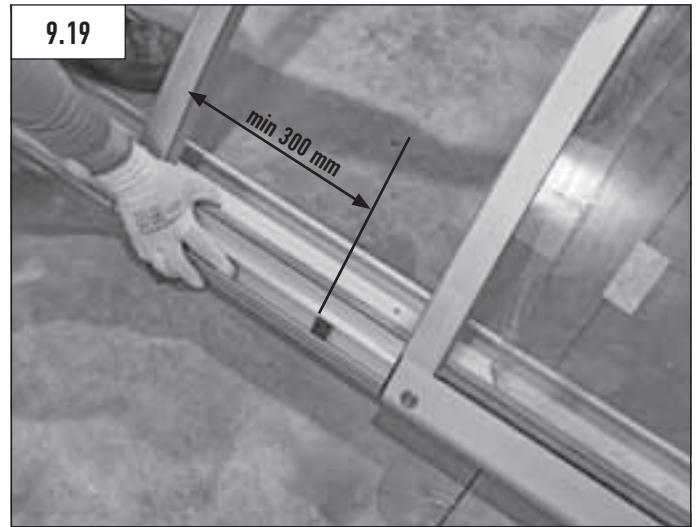
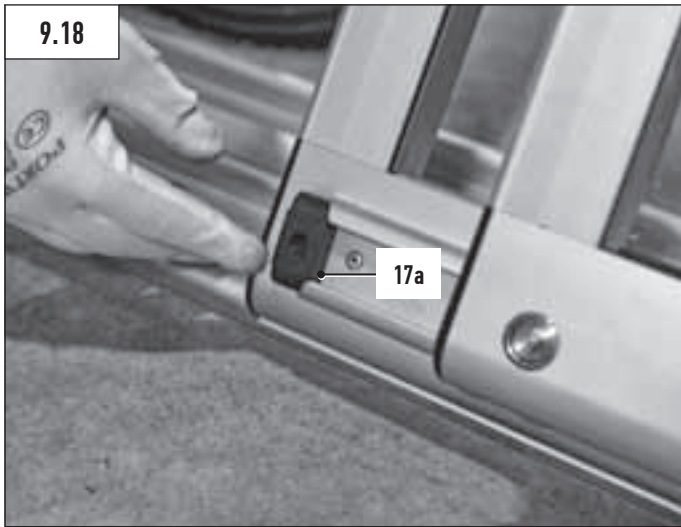

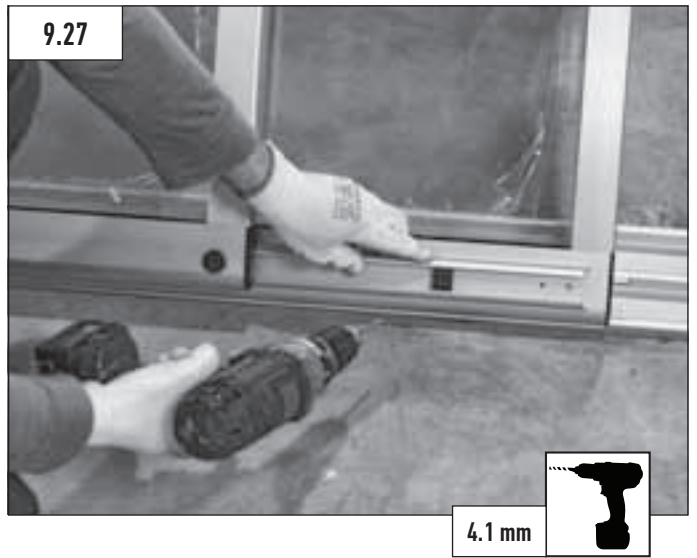
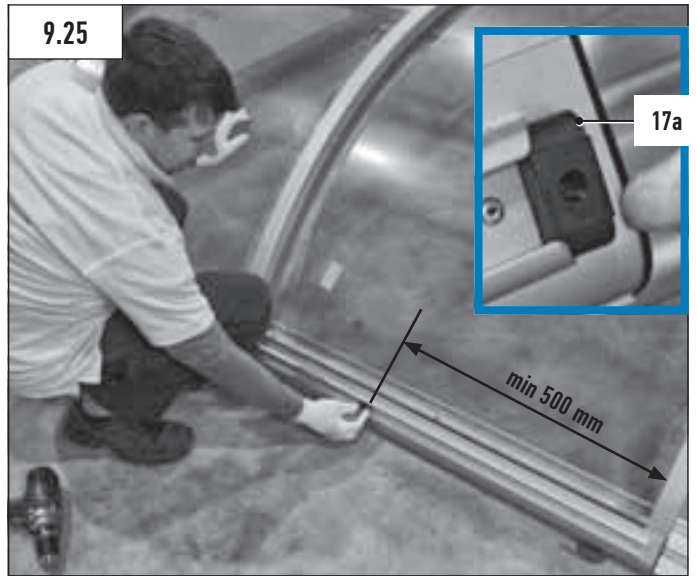

with A5 models





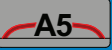
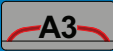
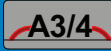

						
Item nr.	Item name	Pcs	Pcs	Pcs		Notes
14c	Buffer	4	4	4		
14a	Rail joiner	6	8	10		
14b	End cap	12	16	30		1 left + 1 right
13	Latch sleeve	3	3	3		

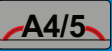
		  				
						
Item nr.	Item name	Pcs	Pcs	Pcs		Notes
14c	Buffer	4	4	4		
14a	Rail joiner	6	8	10		
14b	End cap	12	16	30		1 left + 1 right
13	Latch sleeve	2	2	2		

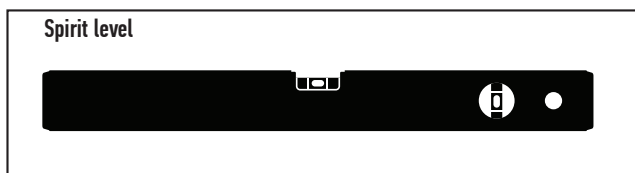
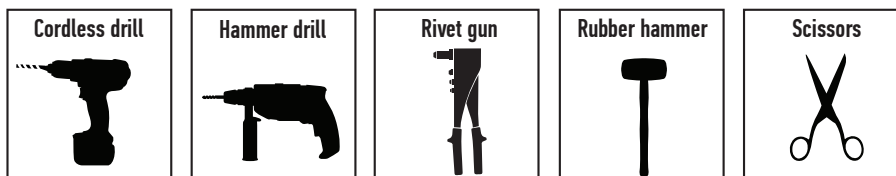

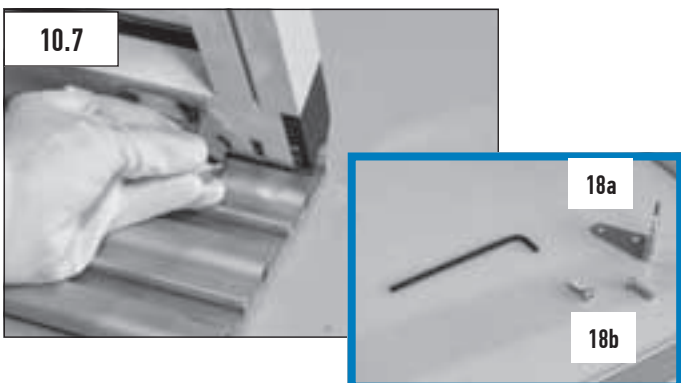
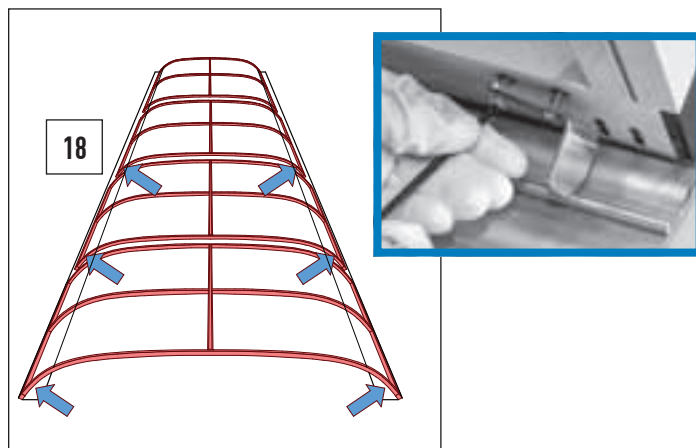
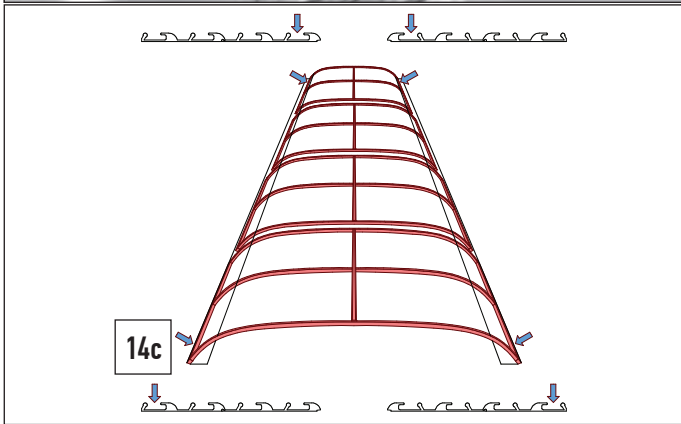
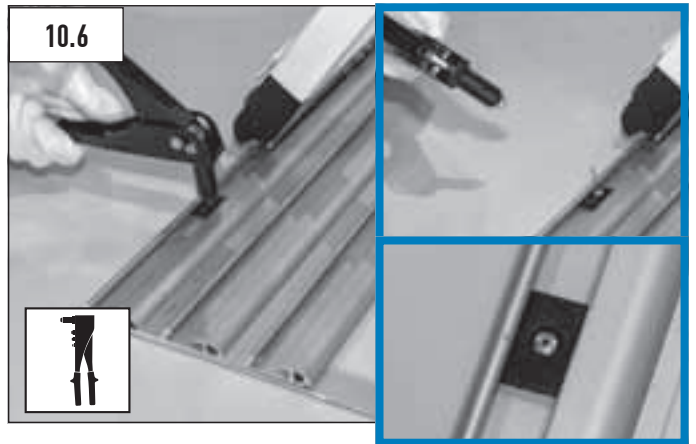
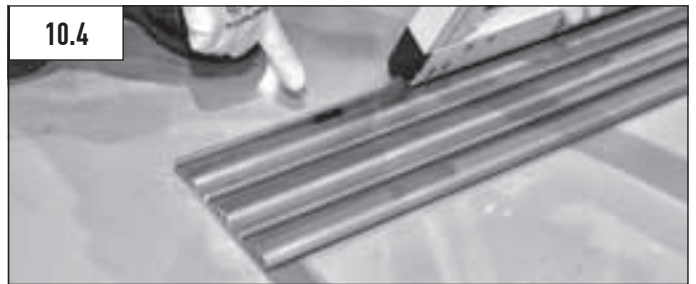
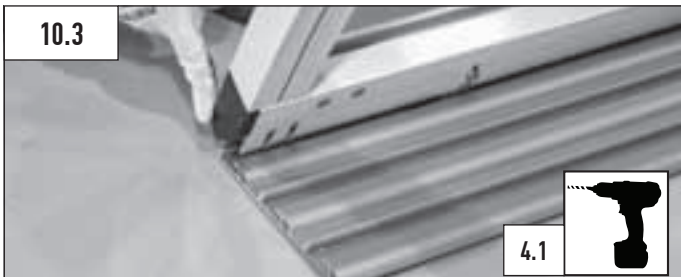
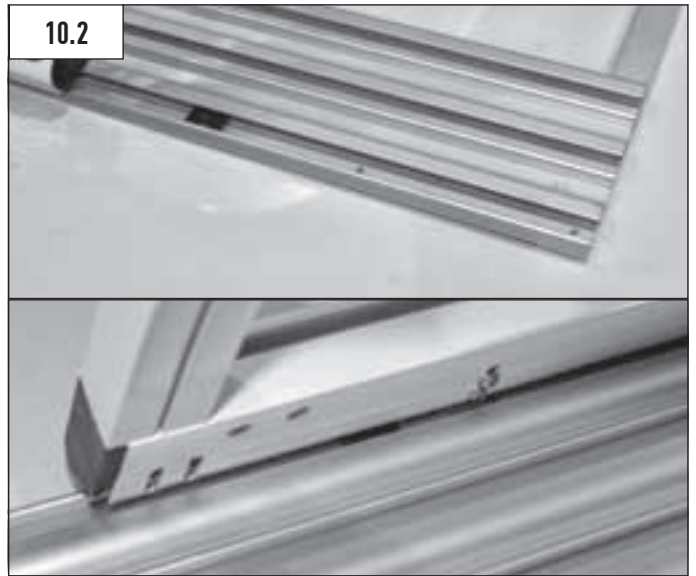
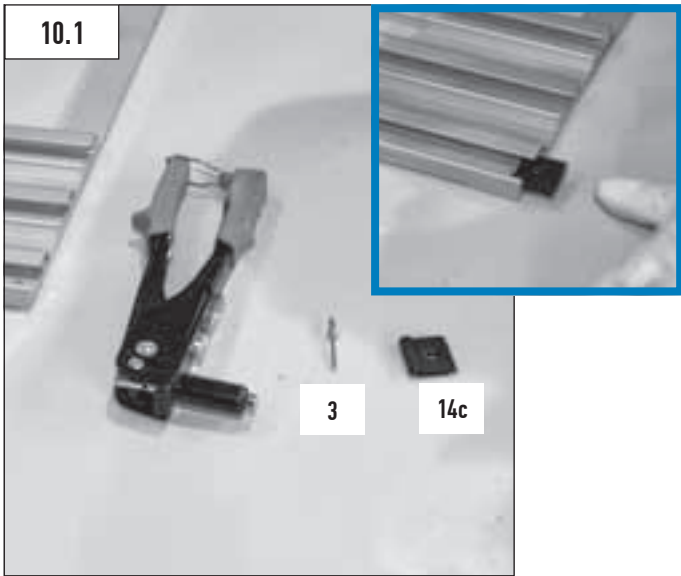

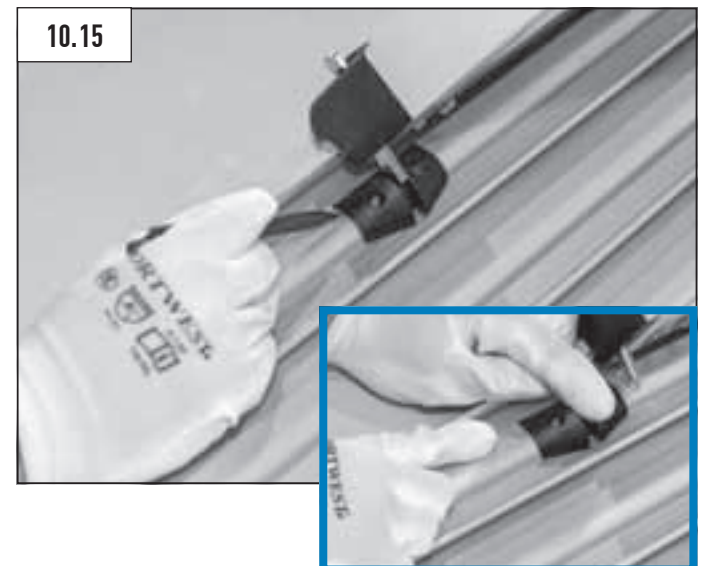
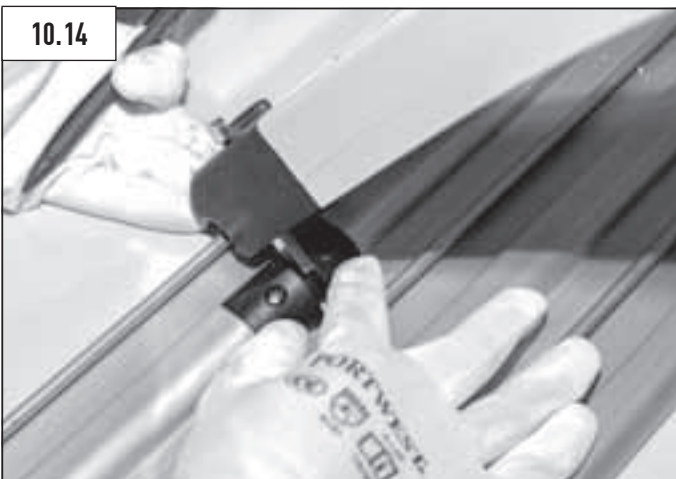
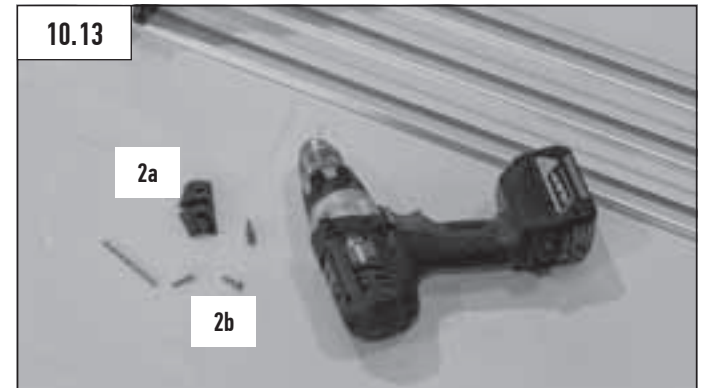
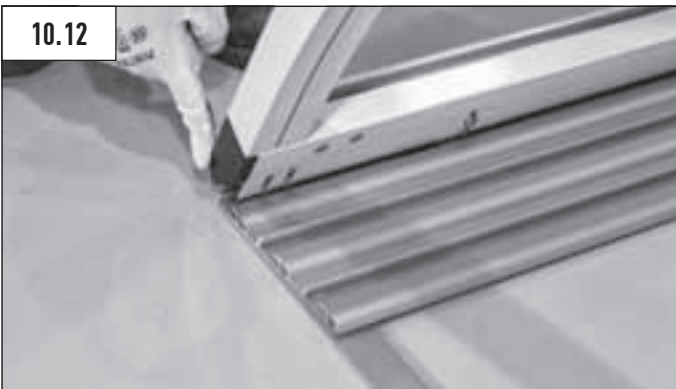
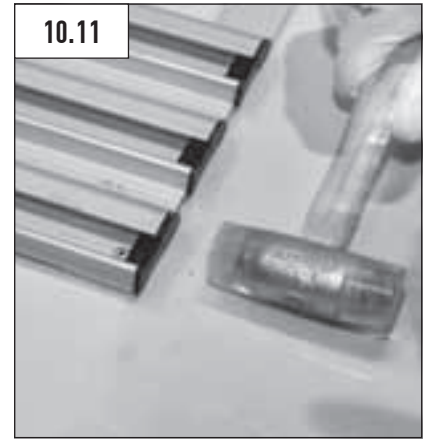
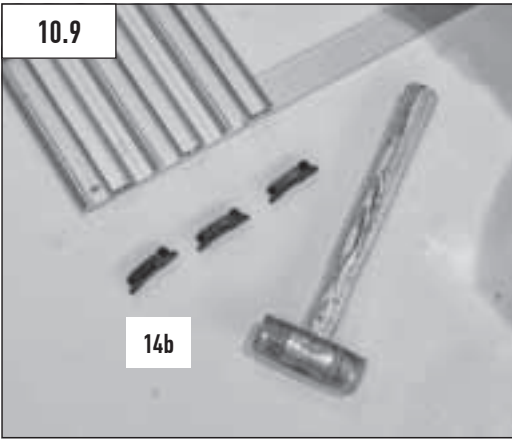

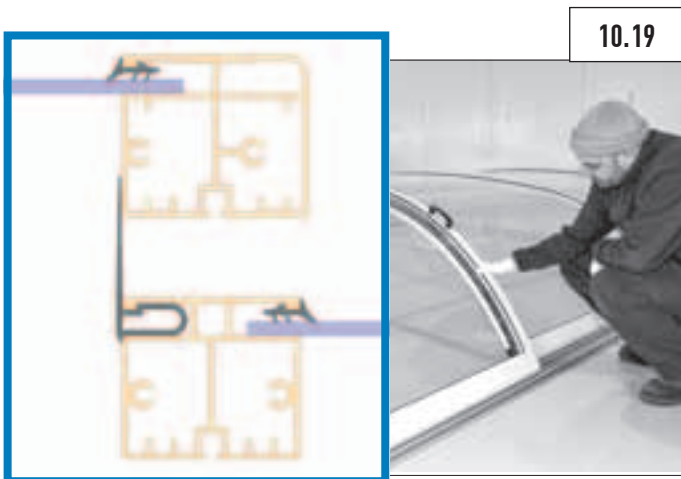
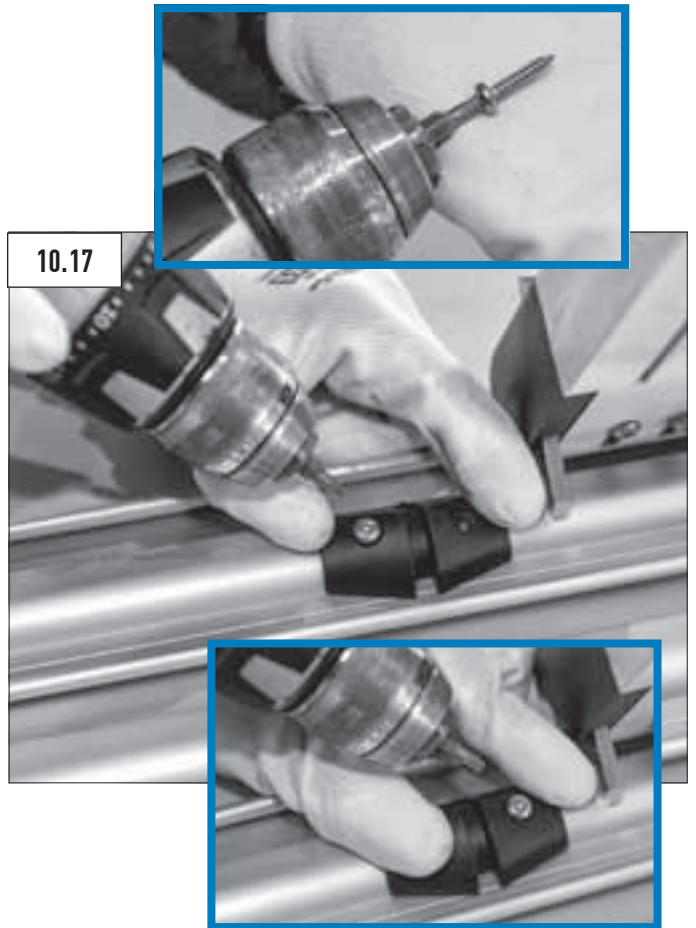
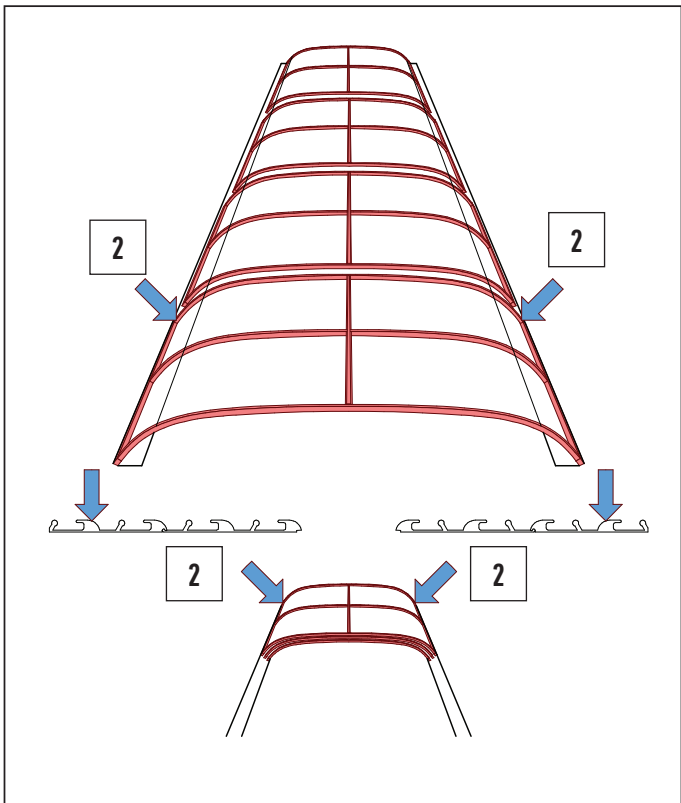

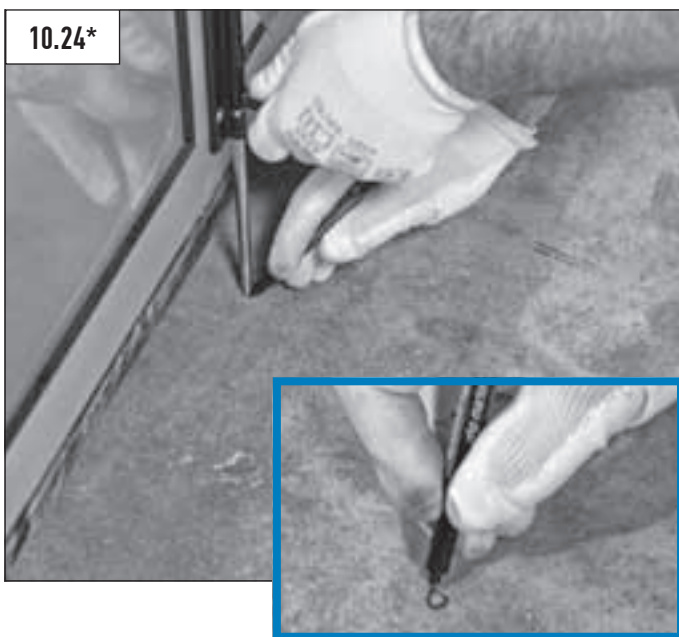
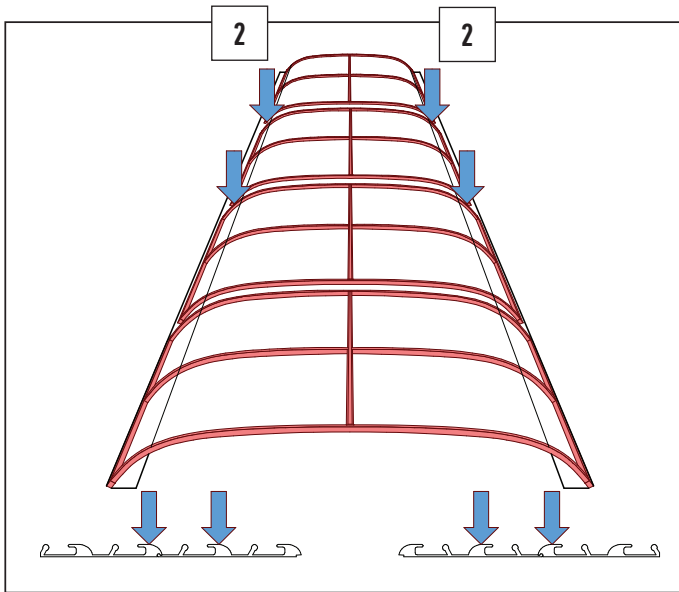

* FLAT MODELS (A) = FRONT AND BACK WALL
STANDARD MODELS (M) = ONLY BACK WALL

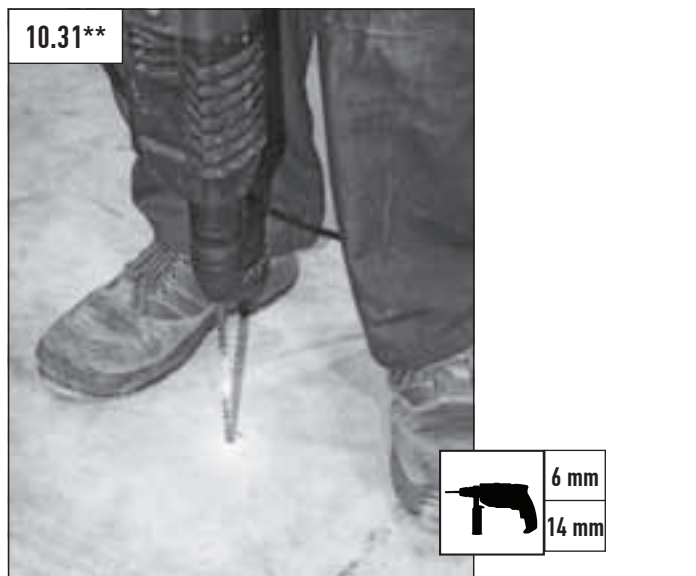
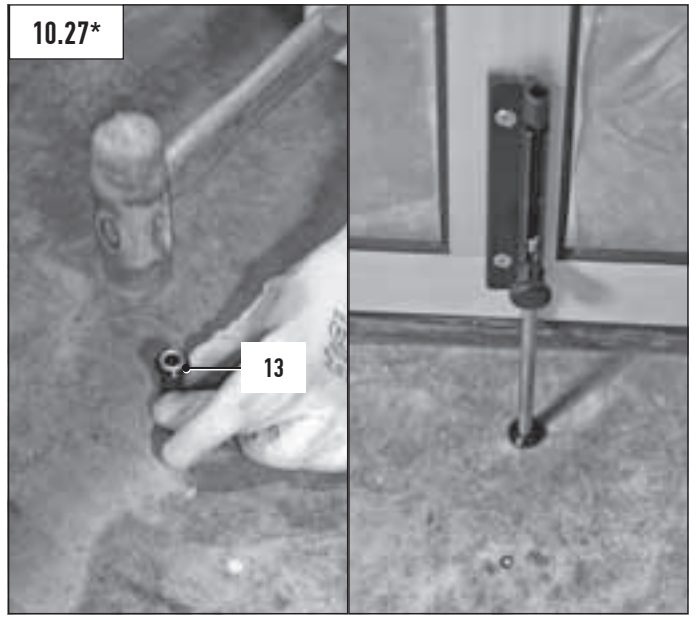
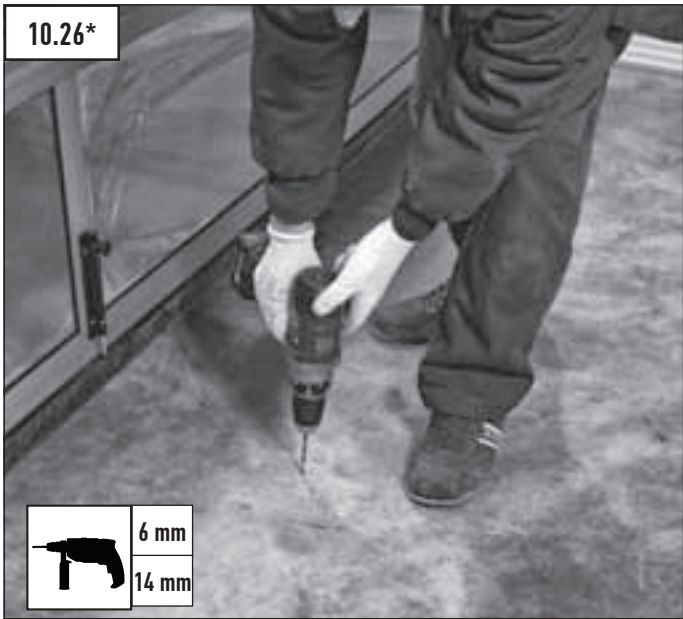

* FLAT MODELS (A) = FRONT AND BACK WALL
STANDARD MODELS (M) = ONLY BACK WALL

**STANDARD MODELS (M) = ONLY FRONT WALL



**STANDARD MODELS (M) = ONLY FRONT WALL

