



HENSOL & DYFFRYN

HOT TUBS

OWNERS MANUAL

230V Systems

Owner's Record

Locating the Spa Serial Number:

The spa serial number label is located inside the equipment compartment. Equipment compartment access panel is below the spas topside control panel. Write your spa information in the space provided.

DATE PURCHASED:

PURCHASED FROM:

SPA MODEL:

SERIAL NUMBER:

See Page 7

Please read this Owner's Manual carefully, as it is designed to provide you with the information you will need to ensure the safe, secure use of your spa.

IMPORTANT: The Manufacturer reserves the right to change specifications and/or design without notification and without any obligation.

SPA SPECIFICATIONS

Model	Spa Seating	Length cm	Width cm	Height cm	Dry Weight	Water Capacity
PLA-42L	6 person	213 cm (84")	213 cm (84")	91 cm (36")	361 kg (796 lbs)	1,298 L (343 gal)
PLA-42NL	7 person	213 cm (84")	213 cm (84")	91 cm (36")	371 kg (818 lbs)	1,249 L (330 gal)
PLA-40DL	5 person	213 cm (84")	213 cm (84")	86 cm (34")	366 kg (807 lbs)	1,105 L (292 gal)
PLA-34L	3 person	165 cm (65")	213 cm (84")	75 cm (29.5")	301 kg (663 lbs)	795 L (210 gal)

CAUTION

DO NOT OPERATE SPA BEFORE READING THIS MANUAL

Failure to read this manual and follow its instructions may result in unsafe operation and or permanent damage to your portable spa.

Most cities, counties, states, and countries require permits for exterior construction and electrical circuits. In addition, some communities have codes requiring residential barriers such as fencing and/or self-closing gates on the property to prevent unsupervised access to a pool or spa by children. Be sure to check with your local agencies for specific requirements.

If you need additional information and/or assistance, please consult your local contractor.

TABLE OF CONTENTS

SAFETY INFORMATION

IMPORTANT SAFETY INSTRUCTIONS	1
IMPORTANT SPA INSTRUCTIONS	4

INSTALLATION

PLANNING A LOCATION FOR YOUR SPA	5
PLACING THE SPA	6

EQUIPMENT ACCESS

EQUIPMENT ACCESS PANEL	7
------------------------	---

ELECTRICAL REQUIREMENTS

ELECTRICAL REQUIREMENT	8
ELECTRICAL SYSTEM	9

CONTROL PANEL OPERATION

DISPLAY OVERVIEW	10
TEMPERATURE ADJUSTMENT	10
JETS OPERATION	11
MULTI COLOR LED LIGHT	11
MODE	11
FILTER CYCLES	11
OPERATIONAL MODES	11
DIAGNOSTIC LCD MESSAGE	13

COMPONENT OPERATION

SPA COMPONENT OPERATION	14
-------------------------	----

FILL-UP AND START-UP INSTRUCTIONS

FILLING THE SPA WITH WATER	15
APPLYING POWER	15

ADDING START-UP CHEMICALS

WATER CHEMISTRY GUIDELINES	16
----------------------------	----

SPA MAINTENANCE

FILTER CARTRIDGE MAINTENANCE	17
SURFACE CARE	18
COVER CARE	18
CABINET CARE	18
REPLACEMENT SPA PARTS	18

DRAINING OR WINTERIZING

DRAINING YOUR SPA	19
WINTERIZING YOUR SPA	19

TROUBLESHOOTING PROCEDURES

NO COMPONENT OPERATION	20
PUMP DOES NOT OPERATE, BUT THE LIGHT DOES	20
POOR JET ACTION	20
WATER IS TOO HOT	20

IMPORTANT SAFETY INSTRUCTIONS

READ AND FOLLOW ALL INSTRUCTIONS

AVOIDING THE RISK TO CHILDREN

DANGER:

- **RISK OF CHILD DROWNING:** Extreme caution must be exercised to prevent unauthorized access by children. To avoid accidents, ensure that children cannot use a spa unless they are supervised at all times. Children should be supervised to not use the spa as a toy.

WARNING:

- To reduce the risk of injury, do not permit children to use this product unless they are closely supervised at all times.
- To reduce the risk of injury, lower water temperatures are recommended for young children. Children are especially sensitive to hot water.

DO:

- Make sure you always lock the child resistant locks after using the spa for your children's safety. Every spa is equipped with a locking cover that meets the ASTM F1346 Standard for Safety Covers.
- Test the water temperature with your hand before allowing your child to enter the spa to be sure that it's comfortable. Children are especially sensitive to hot water.
- Remind children that wet surfaces can be very slippery. Make sure that the children are careful when entering or exiting the spa.

DON'T:

- Allow children to climb onto the spa cover.
- Allow children to have unsupervised access to the spa.

AVOIDING THE RISK OF ELECTROCUTION

RISK OF ELECTROCUTION:

- Connect only to a grounded source.
- Do not bury the power cord. A buried power cord may result in death or serious personal injury due to electrocution if direct burial-type cable is not used, or if improper digging occurs.
- A ground terminal (pressure wire connector) is provided on the control box inside the unit to permit connection of a minimum 6 mm² (10 AWG) solid copper bonding conductor between this point and any metal equipment, metal water pipe, metal enclosures of electrical equipment, or conduit within 1.5 m (5 feet) of the unit as needed to comply with local requirements.

WARNING:

- To reduce the risk of electrical shock, replace a damaged cable immediately. Failure to do so may result in death or serious personal injury due to electrocution.
- A ground terminal is provided on the control box. To reduce the risk of electric shock, connect this terminal to the grounding terminal of your electrical service or subpanel with a continuous green, insulated copper wire. The wire must be equivalent in size to the circuit conductors supplying the equipment. In addition, a bonding terminal (pressure wire connector) is provided on the outside of the control box for bonding to local ground points. To reduce the risk of electric shock, this connector should be bonded with a 8 mm² (8 AWG) solid copper wire to any metal ladders, water pipes, or other metal within 1.5 m (5 feet) of the spa to comply with local requirements. The means of disconnection must be readily accessible, but must be installed at least 1.5 m (5 feet) from the spa.

SAFETY INFORMATION

- Your spa requires a suitably rated circuit breaker to open all ungrounded supply conductors.
- Your spa must have a residual current device (RCD) in an electrical subpanel. Before each use of the spa and with the unit operating, push the TEST button on the breaker. The switch should click over to the "Trip" position. Wait 30 seconds and reset the RCD breaker by switching it completely off and then completely on. The switch should then stay on. If the interrupter does not perform in this manner, it is an indication of an electrical malfunction and the possibility of an electric shock. Disconnect the power until the fault has been identified and corrected.

IMPORTANT: Failure to wait 30 seconds before resetting the RCD may cause the spa's Power Indicator (on the control panel) to blink. If this occurs, repeat the RCD test procedure.

DANGER: RISK OF ELECTRICAL SHOCK

- Install spa at least 1.5 m (5 feet) from all metal surfaces. A spa may be installed within 1.5 m (5 feet) of a metal surface if each metal surface is permanently connected by a minimum 6 mm² (10 AWG) solid copper conductor attached to the wire ground connector on the terminal box that is provided for this purpose if in accordance with your national electrical code.
- Do not permit any electrical appliances, such as a light, telephone, radio, or television within 1.5 m (5 feet) of a spa. Failure to maintain a safe distance may result in death or serious personal injury due to electrocution if the appliance should fall into the spa.
- Install your spa in such a way that drainage is away from the electrical compartment and from all electrical components.

DO:

- Be sure your spa is connected to the power supply correctly - use a licensed electrical contractor.
- Disconnect the spa from the power supply before draining the spa or servicing the electrical components.
- Test the residual current device before each use.

DON'T:

- Use the spa with the equipment compartment door removed.
- Place electrical appliances within 1.5 m (5 feet) of the spa.
- Use an extension cord to connect the spa to its power source. The cord may not be properly grounded and the connection is a shock hazard. An extension cord may cause a voltage drop, which will cause overheating of the jet pump motor and motor damage.
- Attempt to open the electrical control box. There are no user serviceable parts inside.

RISKS TO AVOID

DANGER: RISK OF INJURY

- DO NOT sit in the filter compartment area. Sitting in this area can cause:
 - a) Restriction of Filter Pump suction/vacuum
 - b) Damage to components
- Both can result in bodily harm. Should damage occur to components in this area, replace immediately!

To reduce the risk of injury to persons, DO NOT remove floating weir, basket, and filter located in the filter compartment while the spa is running.

- The suction fittings in the spa are sized to match the specific water flow created by the pump. Never replace a suction fitting with one rated less than the flow rate marked on the original suction fitting.
- There is a danger of slipping and falling. Remember that wet surfaces can be very slippery. Take care when entering or exiting

SAFETY INFORMATION

the spa.

- Never operate spa if the suction fittings are broken or missing.
- The device should not be used by persons (including children) with reduced physical, sensory or mental capabilities, or lack of experience and knowledge, unless they receive supervision or training.
- People with infectious diseases should not use the spa.
- Keep any loose articles of clothing or hanging jewelry away from rotating jets or other moving components.

Increased side effects of medication

- The use of drugs, alcohol or medication before or during spa use may lead to unconsciousness with the possibility of drowning.
- Persons using medications should consult a physician before using a spa; some medication may cause a user to become drowsy, while other medication may affect heart rate, blood pressure, and circulation.
- Persons taking medications which induce drowsiness, such as tranquilizers, antihistamines or anticoagulants should not use the spa.

Health problems affected by spa use

- Pregnant women should consult a physician before using spa.
- Persons suffering from obesity or with a medical history of heart disease, low or high blood pressure, circulatory system problems, or diabetes should consult a physician before using spa.

Unclean water

- Keep the water clean and sanitized with correct chemical care. The recommended levels for your spa are:
Free Available Chlorine: 3.0 - 5.0 ppm
Total Alkalinity: 40 - 120 ppm
Water pH: 7.2 - 7.8
Calcium Hardness: 75 - 150 ppm

ten minutes after adding ANY spa water chemicals into the filter compartment.

- Clean the filter cartridge monthly to remove debris and mineral buildup which may affect the performance of the hydromassage jets, limit the flow, or trip the high-limit thermostat which will turn off the entire spa.

AVOIDING THE RISK OF HYPERTHERMIA

Prolonged immersion in hot water can result in HYPERTHERMIA, a dangerous condition which occurs when the internal temperature of the body reaches a level above normal 37°C (98.6°F). The symptoms of hyperthermia include unawareness of impending hazard, failure to perceive heat, failure to recognize the need to exit the spa, physical inability to exit the spa, fetal damage in pregnant women, and unconsciousness resulting in a danger of drowning.

WARNING:

The use of alcohol, drugs, or medication can greatly increase the risk of fatal hyperthermia in hot tubs and spas.

TO REDUCE THE RISK OF INJURY:

- The water in the spa should never exceed 40°C (104°F). Water temperatures between 38°C and 40°C (100°F and 104°F) are considered safe for a healthy adult. Lower water temperatures are recommended for extended use (exceeding 10 minutes) and for young children. Extended use can cause hyperthermia.
- Pregnant or possibly pregnant women should limit spa water temperatures to 38°C (100°F). Failure to do so may result in permanent injury to your baby.
- Do not use spa immediately following strenuous exercise.

IMPORTANT: Turn jet pump on for at least

SAFETY INFORMATION

AVOIDING THE RISK OF SKIN

BURNS:

- To reduce the risk of injury, before entering a spa the user should measure the water temperature with an accurate thermometer.
- Test the water with your hand before entering the spa to be sure it's comfortable.

SAFETY SIGN:

A SAFETY SIGN is included in the owner's package. The sign, which is required as a condition of Product Listing, should be permanently installed where it is visible to the users of the spa.

IMPORTANT SPA INSTRUCTIONS

The following contains important spa information, and we strongly encourage you to read and apply them.

DO:

- Use and lock the cover when the spa is not in use, whether it is empty or full.
- Follow the Spa Care and Maintenance recommendations stated in this manual.
- Use only approved accessories and recommended spa chemicals and cleaners.

DON'T:

- Leave the spa exposed to the sun without water or the cover in place. Exposure to direct sunlight can cause solar distress of the shell material.
- Roll or slide the spa on its side. This will damage the siding.
- Lift or drag the cover by using the cover lock straps; always lift or carry the cover by using the handles.
- Attempt to open the electrical control box. There are no user serviceable parts inside. Opening of the control box by the spa owner will void the warranty. If you have an operational problem, carefully go through the steps outlined in the Troubleshooting section. If you are not able to resolve the problem, contact your authorized dealer. Many problems can easily be diagnosed over the telephone by an Authorized Service Technician.

PLANNING A LOCATION FOR YOUR SPA

Consider these things when determining where to place your spa.

SAFETY FIRST:

Make sure your spa is positioned so access to the equipment compartment and side panels will not be blocked. Be certain your installation will meet all city and local safety codes and requirements.

PLANNED USE OF SPA:

How you intend to use your spa will help you determine where you should position the spa. For example, will you use it more for recreational or therapeutic purposes? If your spa is mainly for family recreation, leave plenty of room around it for activity and lawn furniture. If you will use it more for relaxation and therapy, you'll probably want to create privacy around the spa.

PRIVACY:

Think of your surroundings during all seasons to determine your best privacy options. Consider the view of your neighbors when you plan the location of your spa.

VIEWS:

Think about the direction you will be facing when sitting in your spa. Do you have a special landscape you will find enjoyable? Perhaps there is an area that has a soothing breeze during the day or a lovely sunset in the evening.

ENVIRONMENT:

If you live in a climate with a snowy winter and hot summer, a place to change clothes or a house entry near the spa is convenient. A warmer climate may require shade from the hot sun. Consider placement of trees, shrubs, patio cover or perhaps a gazebo structure to provide what you will need. Indoor installations require adequate ventilation. When the spa is in use, considerable

amounts of moisture are produced. This moisture can damage walls and ceiling surfaces over time. Special paint is available to resist moisture damage. Remember that spas periodically require drainage, so plan your environment accordingly.

KEEP CLEAN:

Prevent dirt and foliage from being tracked into your spa by utilizing concrete for paths and access areas. Check the location of spill paths from gutters, trees, and shrubs.

SERVICE ACCESS:

Many people choose to install tile or custom wood around their spas. If you are installing your tub with custom decorative trimming, remember to allow for access to it for service. Should you need service, a technician may need to remove the tub's door panel, or access it from beneath. It is always best to design special installations so the spa can still be moved, or lifted from the ground.

A GOOD FOUNDATION:

Your new spa needs a good solid foundation. The area your spa sits on must be able to support the spa, the water in it and those who use it. If the foundation is inadequate, it may shift or settle after the spa is in place, causing stress to the shell or components. **NOTE:** Do not shim your spa in any manner, as this could cause the cabinet to crack, thereby voiding the warranty.

BE AWARE:

Damage caused by inadequate or improper foundation support is not covered by the spa warranty. It is the sole responsibility of the spa owner to provide a proper foundation for the spa.

Make sure the foundation where the spa is placed drains water away from the spa. Proper drainage will keep components dry from rain and wet weather.

Your spa weight must always be considered when installing your spa. If you are installing

it on an elevated wood deck or other structure, it is advisable to consult a structural engineer or contractor to ensure the structure will support the weight.

IT IS STRONGLY RECOMMENDED THAT A QUALIFIED, LICENSED CONTRACTOR PREPARE THE FOUNDATION FOR YOUR SPA.

A reinforced concrete pad at least four inches thick is recommended for your spa. The reinforcing rod or mesh in the pad should be attached to a bond wire.

INDOOR INSTALLATION:

Be aware of some special requirements if you place your spa indoors. Water will accumulate around the spa, so flooring materials must provide a good grip when wet. Proper drainage is essential to prevent a build-up of water around the spa. When building a new room for the spa, it is recommended that a floor drain be installed. The humidity will naturally increase with the spa installed. Water may get into woodwork and produce dryrot, mildew, or other problems. Check for airborne moisture's effects on exposed wood, paper, etc. in the room. To minimize these effects, it is best to provide plenty of ventilation to the spa area. An architect can help to determine if more ventilation must be installed.

PLACING THE SPA

CHECK THE DIMENSIONS OF YOUR SPA:

Compare the spa dimensions to the width of gates, sidewalks, and doorways along the delivery route used to bring the spa into your yard. It may be necessary for you to remove a gate or partially remove a fence in order to provide an unobstructed passageway to the installation location. Also, keep in mind—if you are using special equipment to place your spa into an area it will be necessary to include those measurements and weights.

PLANNING A DELIVERY ROUTE:

Check the width of gates, doors and sidewalks to make sure your spa will pass through unobstructed. You may have to remove a gate or part of a fence to allow for adequate width clearance. If the delivery route will require a 90-degree turn, check the measurements at the turn to ensure the spa will fit. Check for protruding gas meters, water meters, A/C units, etc., on your home which will cause obstructions along the delivery path to your yard. Check for low roof eaves, over hanging branches or rain gutters that could be an obstruction to overhead clearances.

SPECIAL CIRCUMSTANCES:

The use of a crane for delivery and installation is primarily to avoid injury to your spa, your property or to delivery personnel. Cranes are not considered "normal delivery".

EQUIPMENT ACCESS

EQUIPMENT ACCESS PANEL

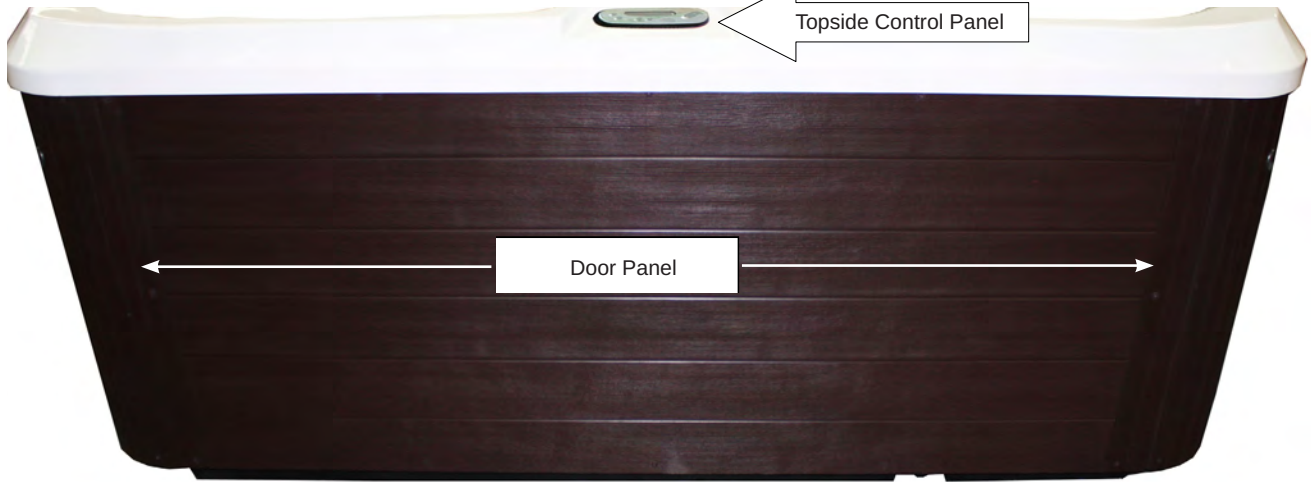

To access the equipment compartment "Front Side of Spa":

Remove all the screws around the top, bottom and sides of the large full panel door. Lower door panel slightly, pull bottom of door away from spa then remove.

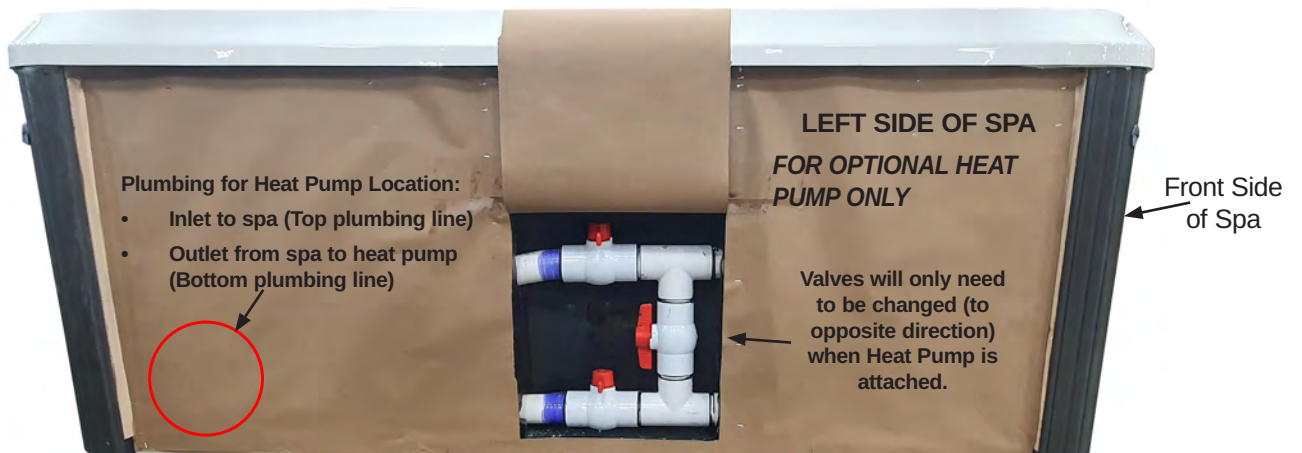
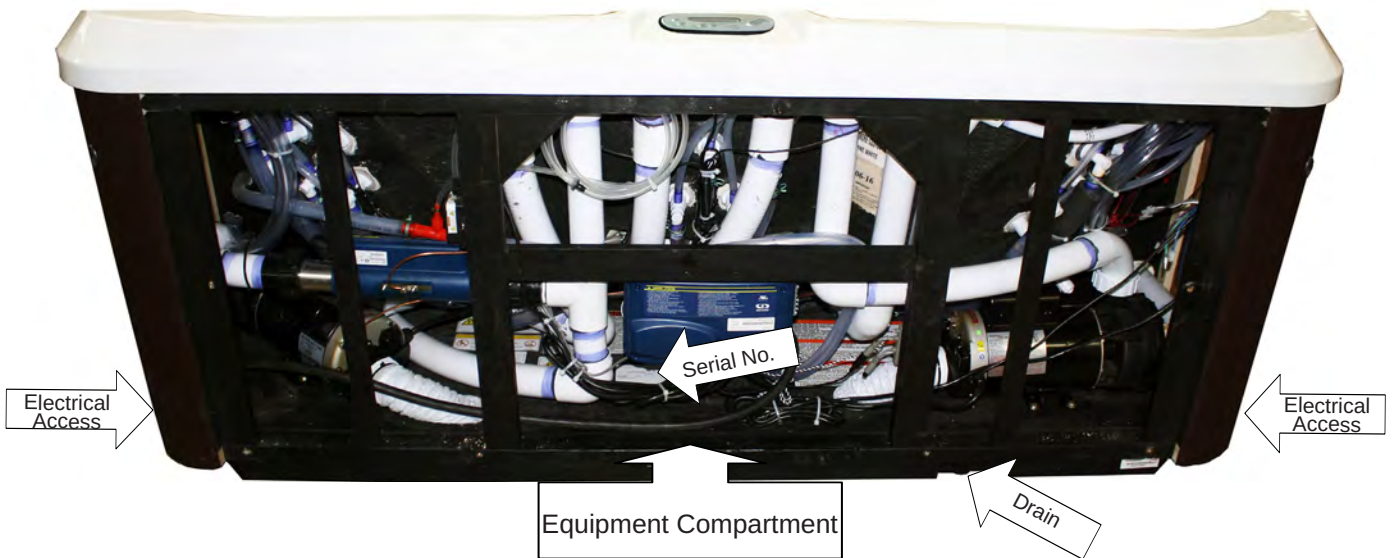

ELECTRICAL REQUIREMENTS

ELECTRICAL REQUIREMENT

⚠ DO NOT POWER THE SPA WITHOUT FIRST FILLING WITH WATER!

⚠ DANGER – RISK OF ELECTRIC SHOCK

Installations that do not conform to the following procedures and requirements may expose users to electric shock. Non-conforming installations will not be covered under warranty.

The electrical wiring of this spa must meet the requirements of your National Electric code and any applicable state or local codes. The electrical circuit must be installed by an electrical contractor and approved by a local building electrical inspection authority.

1. Installations within 1.5 m (5 feet) of any metal surfaces must ground the metal surfaces to the spa. Use an 8 mm² (8 AWG) solid copper wire and attach it to the grounding lug on the control box, located in the equipment compartment.
2. Only a licensed electrician may install power to the spa.
3. Power supply installation must include a suitably rated residual current device RCD as required by your National/local code. The circuit breaker must be dedicated and should not be shared with any other appliances. It must be labeled and easily accessible to users.
4. The electrical supply for the spa must include a suitable circuit breaker to open all ungrounded supply conductors to comply with your National/local code. The disconnecting means must be readily accessible to the spa's occupant but installed at least 1.5 m (5 feet) from the spa water.

5. Power supply lines must be hard wired into the power pack. When hard wired, the use of a shut-off box near the spa is also recommended. This box provides a quick and convenient method to shut off power to the spa for emergencies and maintenance.
6. Supply lines must be properly sized as per your National/local electric code. A ground line must be provided that is as large as the largest current carrying conductor, but no less than 6 mm² (10 AWG). Use copper wiring only.
7. Please open the front cover of the control box, and follow the instructions and wiring diagram printed on the backside.
8. 230V HARD WIRED SPAS
 - Wire size must be appropriate per your national electric code and/or local codes.
 - Wire size is determined by length of run from breaker box to spa and maximum current draw.
 - All wiring must be copper to ensure adequate connections. Do not use aluminum wire.



Equipment access is below the topside control panel.

ELECTRICAL REQUIREMENTS

ELECTRICAL SYSTEM

When using a 230V 50Hz system, attach the wires to the terminals as shown below.

CIRCUIT BREAKER REQUIREMENTS:

A new RCD circuit breaker must be used for your spa installation. Do not use an existing breaker, as its condition is unknown.

The standard 1 pump model requires a 230V 50Hz 13 amp system having a single electrical service (using one 16 amp breaker) with 3 wires.

The spa must be connected to a dedicated RCD circuit breaker that is not shared with any other equipment. Do not use extension or plug type cords of any kind.

1 PUMP

PLA-42L

PLA-42NL

PLA-40DL

PLA-34L

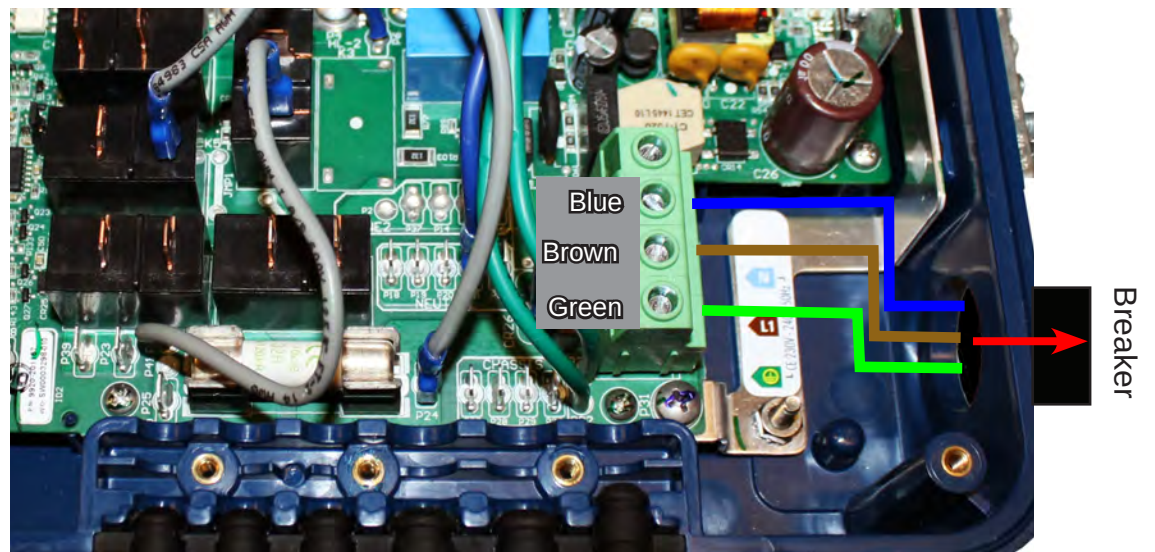

CONTROL PANEL OPERATION

INITIAL START-UP - When the spa is first powered up the control system begins a 2 minute Startup Mode. Different codes will display on the screen. Once Startup Mode completes, the actual temperature is displayed on the screen, and the spa will then begin to heat, maintain the water temperature and the first filter cycle will start 5 minutes later. Your spa has been designed so that it will automatically heat the water to the factory set temperature of 38°C (100°F) unless you set the spa to a different temperature. If power is disconnected from the spa, it will automatically revert back to the last saved set temperature when power is reapplied.



TEMPERATURE ADJUSTMENT

The temperature can only function between 26°.5C - 40°C (80°F - 104°F). The last measured temperature will constantly display on LCD.

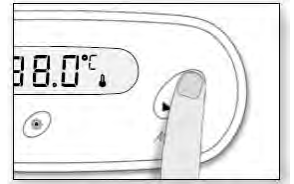
Press the Up/Plus or Down/Minus buttons to display the set temperature (desired temperature) and indicator .



Each time either button is pressed again, the set temperature will increase or decrease depending on which button is pressed. After five seconds, the LCD will automatically display the current spa temperature.

The "heater" indicator  lights up when the heater is on. It flashes when there is a request for more heat, but the heater is not on. Once set temperature is reached the indicator  shuts off and the low speed of the jet pump turns off after 30 seconds (if not in filter cycle).

DISPLAY OVERVIEW

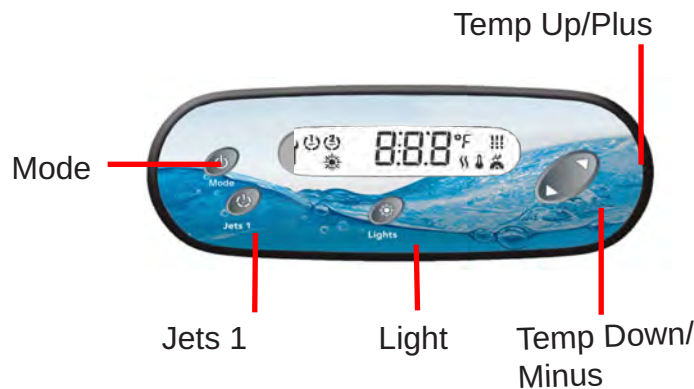

Pump icon
The "Pump" indicator number lights up when the pump is in high speed, and flashes when the pump is in low speed.

Service icon
A problem has been detected. Do not enter the water! Spa service is required.

Light icon
The "Light" icon lights up when the light is on.

Temperature & message digits

°F/°C

Filter Cycle icon
The "Filter Cycle" icon lights up when filter cycle is on. The icon flashes if the filter cycle is disrupted.

Smart Winter Mode icon
The "SWM" icon automatically turns on when freeze protection is active. It flashes while system purges the spa plumbing.

Heater icon
The "Heater" icon lights up when the heater is on. It flashes when:
1- There is a call for heat and heater has not started yet,
2- Heater has just turned off and element is cooling down
3-Not enough current available to start heater

Set Point icon
The "Set Point" icon automatically turns on when set point setting menu is activated.

CONTROL PANEL OPERATION

JETS OPERATION

Jet Pump 1 button:

- Press Jets 1 button once to turn Jet Pump 1 on low speed.
- Press Jets 1 button a second time to turn Jet Pump 1 on high speed.
- Press Jets 1 button a third time to shut Jet Pump 1 Off.

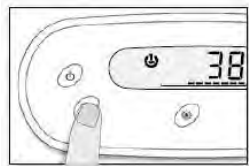



MULTI COLOR LED LIGHT

Press the *Light* button once to turn on the lights, press the button again to turn the lights off, when turning back on after several seconds the same light mode will appear. Every time the light is quickly turned off and on a new light mode will appear. The sequence is as follows: White, Aqua, Magenta, Azure, Amber, Emerald, Ruby, Color wheel with abrupt color changes, Slow full color wheel and Fast full color wheel.

NOTE: If left on, the light will automatically turn off after 4 hours of operation.

OPERATIONAL MODES

FILTER CYCLES

There are two filter cycles: the first cycle (F1) starts right after power up and the second cycle (F2) will start 12 hours later. The default duration for the first filter cycle is 1 hour, and 30 minutes for the second cycle. The "Filter" indicator  lights up when a filter cycle  is on. The duration of each filter cycle can be modified. If the "Filter" indicator  flashes, this indicates there has been a suspension in the filter cycle.

ADJUSTING PRESET FILTER CYCLES

Filter duration is programmable between 0.5 and 6 hours in 30 minute increments (0.5 hours) for both filter cycles. To program the cycle times:

1. Press and hold *Light* button for 5+ seconds until F1 is displayed.
2. Press the *Plus* or *Minus* button to adjust the cycle time for F1.
3. Press the *Light* button to store the F1 cycle and move to the F2 cycle.
4. Press the *Plus* or *Minus* button to adjust the cycle time for F2.

5. Wait 15 seconds to allow the exit timer to expire and store the setting.

IMPORTANT: To reset the first filter cycle start time, skip step 5 and continue pressing the *Light* button until the actual temperature is displayed. Powering down of the spa will also reset the first filter start time.

FILTER CYCLE SUSPENSION:

The filter cycle will be suspended every time a jet pump or light is activated manually during the filter cycle time. The suspension will end around 15 minutes after the completion of the manual use. **IMPORTANT:** To restart the filter cycle immediately, press the Mode button placing the spa in the cleanup mode.

ECONOMY MODE:

This mode allows you to lower the temperature set point of the spa by 11°C (20°F), to change to the Economy mode press and hold *Light* button for 5+ seconds until F1 is displayed. Press the *Light* button several times until the display shows EP 1 or use Down key to disable economy mode, the display will show EP 0. Wait 15 seconds to allow the exit timer to expire and store the setting.

OPERATIONAL MODES

The Standard Mode is the default operational mode preset from the factory. In order to program the spa to operate in the Economy mode you must enter the programming mode to make the change.

Water sampling will turn the jet pump on and circulate the water for up to a couple of minutes.

NOTE: Freeze Protection (Smart Winter Mode) will assert as necessary during all modes.

STANDARD MODE: Is programmed to maintain the desired temperature with periodic water circulation (sampling) to sample and heat the water to the set temperature.

ECONOMY MODE: The spa will not heat. Water sampling only done during the filter cycle.

SLEEP MODE: The spa will only heat during the filter cycles. Water sampling only done during the filter cycle

CONTROL PANEL OPERATION

QUIET MODE: Keeps the jet pump from running (water sampling) after the F2 filter cycle is complete for up to 11.5 hours. You can set this mode between 0.5 hours and 11.5 hours in half hour increments.

To enter the programming screen and toggle between Standard, Economy, Sleep and Quiet Modes the following is required:

FAHRENHEIT/CELSIUS

SETTING:

To change water temperature display to either Fahrenheit or Celsius, press and hold Light button for 5+ seconds until F1 is displayed. Press the Light button several times until F or C is displayed. Press the Plus or Minus button to change. Wait 15 seconds to allow the exit timer to expire and store the setting.

CONTROL PANEL OPERATION

DIAGNOSTIC LCD MESSAGE

Message	Meaning	Action Required
	No message on display. Power has been cut off to the spa.	The control panel will be disabled until power returns. Spa settings will be preserved until next power up.
HL	The system has shut the heater off because the temperature at the heater has reached 48°C (119°F). Do not enter the water!	DO NOT ENTER THE WATER. Remove the spa cover and allow the water to cool down, then shut power off and power your spa up again to reset the system. If spa does not reset, shut off the power to the spa and call your Local Dealer.
AOH	Temperature inside the equipment compartment is too high 90°C (194°F), causing the internal temperature in the control system to increase above normal limits.	Open equipment compartment and wait until error clears.
Prr	A problem is detected with the temperature probe.	Call your Local Dealer.
OH	The water temperature in the spa has reached 42°C (108°F). Do not enter the water!	Remove the spa cover and allow the water to cool down to a lower temperature. Call your local Dealer or service supplier if problem persists.
Hr	An internal hardware error has been detected.	Call your Local Dealer.
FLO	No water flow is detected by the control system but flow is expected.	Make sure that the jet pump is running and water is flowing; check and clean filters; make sure water valves are open; make sure spa has a proper water level. If problem persists, call your Local Dealer.

 WARNING! SHOCK HAZARD! NO USER SERVICEABLE PARTS.

Do not attempt service of the control box. Contact Customer Service for assistance. Follow all owner manual power connection instructions. Installation must be performed by a licensed electrician and all grounding connections must be properly installed.

SPA COMPONENT OPERATION

AIR CONTROL VALVE

The air control valves (smaller valves) serve to regulate the amount of air mixed with the water when the jets are operational. Turn the air control valves in one direction to increased jet action. Rotating the air control in the opposite direction to turn air off and allow the jets to work with water only. Turn the air controls off when the spa is not in use, this will prevent cold air from entering the spa and will keep heating cost to a minimum. The ozone jet, will always produce air bubbles when pump is on.

DIVERTER VALVE (WHEN EQUIPPED)

The diverter valve on your spa allows you to direct the flow of water from the pump to one of two combinations of jets. The function of the diverter valve can best be learned by experimentation. Turn the large valve all the way to one side or the other to see which jets are on.

HYDROTHERAPY JETS

The hydrotherapy jets are recessed in the wall of the spa. Rotate the large or medium jet faces to turn the jets on or off. Turning a jet on or off will increase or decrease the effects of any jets not in the closed position.

OZONE GENERATOR (OZONE READY)

The ozone system enhances the quality of the spa water when used to supplement the spa owner's regular water maintenance program. Contrary to some information circulated throughout the pool and spa industry regarding ozone systems, ozone CAN'T be used as a single-source sanitizer, water clarifier, anti-foamer, and mineral chelating agent. A secondary source sanitizer must be used to maintain 3.0 -5.0 ppm of Free Available Chlorine (FAC). It is recommended that a chemical maintenance program based on recognized and documented industry standards still be followed when using an ozone purification system to assure

water sanitation and the highest quality purified water.

WATERFALL

Your spa has a control valve to operate the amount of flow through the waterfall from no flow to a steady stream. This valve is next to the waterfall. The waterfall will only work when the Jet Pump is on. Rotate valve to turn on or off.

NOTE: Should any of the 3 waterfall streams stop or the amount of flow becomes inconsistent, the following is required:

1. Turn black cap ¼ turn counter-clockwise and remove.
2. Remove O-Ring.
3. Using Needle Nose Pliers insert half in and half out of center of nozzle, grab with pliers and pull nozzle assembly out.
4. A clear plastic filter with small holes will still be inside the hole, place hand over hole and turn waterfall valve on slightly to have the water push filter towards the top, if water doesn't push it out into your hand use Needle Nose Pliers and pull out while waterfall is OFF.
5. Turn waterfall on to remove any debris inside waterfall hole then turn off. Clean any debris clogging the clear filter holes with water only.
6. Attach clear filter to bottom of nozzle assembly then insert assembly back into waterfall hole.
7. Attache O-Ring.
8. Place black cap back onto hole and turn ¼ turn clock-wise to complete cleaning process.

MUSIC (WHEN EQUIPPED)

Your spa is equipped with a Bluetooth music sound system that requires a bluetooth device to pair up with the spa. To pair the spa and Bluetooth device:

- Go to the Bluetooth settings on you device and find in.stream 2 and press connect.
- Enter pin 5555 and press pair to sync your device. You are now ready to play audio from your device.

FILL-UP AND START-UP INSTRUCTIONS

The following procedures should be followed on initial startup and whenever the spa is drained for routine maintenance.

FILLING THE SPA WITH WATER

1. Clear all the debris from your spa.
2. Be sure to open all jets to allow as much air as possible to escape from the plumbing during the filling process.
3. Verify Drain cap is attached and tight.
4. Insert a garden hose into filter compartment to fill your spa.

NOTE: Do not use hot or softened water.

5. As the water level rises, check inside the equipment compartment for water leaks. It may be necessary to tighten unions and/or fittings that may have loosened during delivery. There is no need to call for service; this can easily be done. If assistance is required contact your local dealer.
6. Under normal circumstances keep the water level half way between the top of the spa and the top of the gray filter ring or just above the highest jets (whichever is higher).

Failure to keep enough water in your spa may result in damage to your system and invalidate your warranty. If your spa filter is sucking in air causing the pump to cavitate,

you need to add water!

7. Check the filter installation and make sure the filter is not loose.

APPLYING POWER

1. Turn power to spa "ON" (after filling spa) from the main panel at the house and the subpanel.
2. Press *Jets* button 1 on the topside control panel to activate the spa. Rotate all the air control valves clockwise and observe the increased jet action (air mixed with water).
3. While the pump is running check again for water leaks at the drain spigot, unions, or fittings in the equipment compartment (leaks may have occurred during transit). If water is leaking from one of these areas, there is no need to call for service. Simply tighten the fitting. If assistance is required contact your local dealer.
4. After checking your spa for leaks it is now time to adjust your spa settings. Press the *Plus* or *Minus* button on your topside control panel until the display indicates your desired temperature is set, after 5 seconds of non activity the control panel will display the actual water temperature.

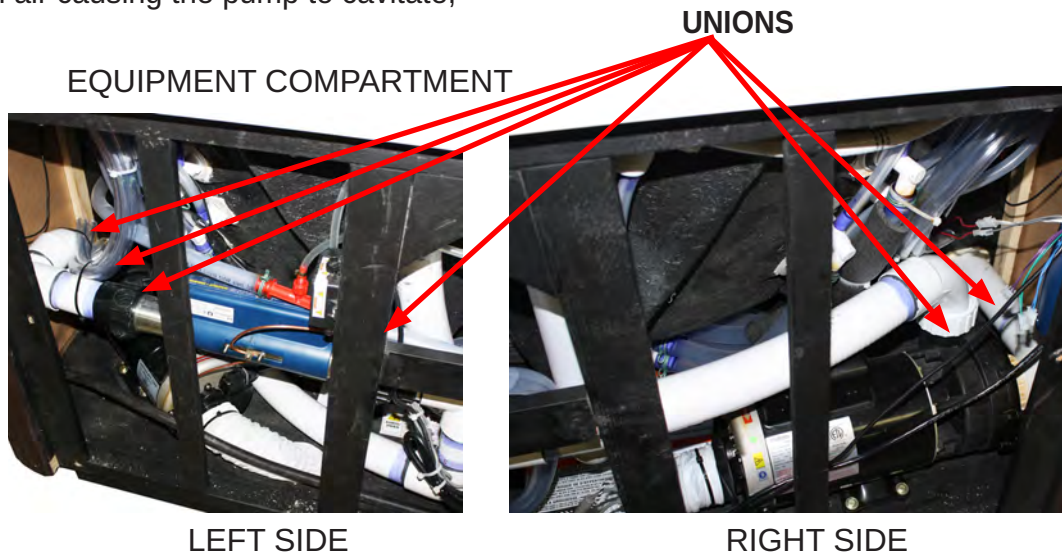

WATER CHEMISTRY GUIDELINES

Spa water chemistry is ultimately the responsibility of the spa owner. Improper water chemistry may result in costly repairs not covered under the spa warranty. If unsure about any step in the process, please contact your local Dealer.

Initially, it is advisable to identify what minerals (e.g. iron) are present in the local source water. This will provide a better understanding of how to treat the water. Please follow the four steps below and be sure to achieve the correct levels in each area before moving onto the next step.

STEP #1: MEASURE TOTAL ALKALINITY:

The Total Alkalinity is the amount of bicarbonates, carbonates, and hydroxides present in the spa water. Proper total alkalinity is important for pH control. If the TA is too high, the pH is difficult to adjust. If the TA is too low, the pH will be difficult to hold at the proper level. The ideal range is between 40-120 parts per million (ppm). Reduce TA by using an Alkalinity Down/Decreaser (sodium bisulfate). Increased TA by adding an Alkalinity Up/Incraser (sodium bicarbonate or sodium hydrogen carbonate). These products should be added in small amounts (1 tablespoon) at a time. After adding 1 tablespoon, wait one half hour before re-measuring. Once the safe range of total alkalinity is established, proceed to the next step.

STEP #2: ESTABLISH PROPER PH LEVEL:

The recommended range for pH is between 7.2 and 7.8. Above 7.8, the water is too alkaline and can result in cloudy water, and scale formation on the shell and heater. To lower the pH use a pH Down/Decreaser (sodium bisulfate). Below 7.0 (considered neutral), the spa water is too acidic and can damage the heating system. To increase pH, use a pH Up/Incraser (sodium hydrogen

carbonate). Any pH Up or Down should be added one teaspoon at a time, waiting one-half hour between application and re-measuring.

STEP #3: DETERMINE CALCIUM HARDNESS:

It is important to bring the calcium reading to between 75-150 ppm. If the reading requires adjustment, it should now be corrected. If the water is too soft (a low reading) calcium hardness should be added to the water to increase the ppm reading. If the water is too hard (a high reading), it can be corrected by either: (A) a mixture of hard and soft water added to attain a reading in the safe range, or (B) addition of stain and scale control. If calcium hardness is a problem with the local source water (either too hard or too soft) a test kit, which measures calcium hardness, is essential.

STEP #4: SANITIZING:

After steps 1-3 are complete, **the spa must be sanitized using Chlorine (sodium dichlor)**. Add 2 teaspoons of Chlorine, and increase as necessary to reach a level of 3-5 ppm. Check and maintain this level weekly, and before and after using the spa. **IMPORTANT NOTE:** *A granulated sodium dichlor is highly recommended for sanitizing spa water. Never use compressed sanitizers even with a floater. As with any other chemicals, the sanitizer should be introduced to the spa in the filter area with the jets running for 10 minutes.*

WEEKLY SHOCK:

Using a potassium monopersulfate (MPS) shock, add approximately 60 ml (2 oz) over the filter while the jets are running. Shocking is achieved by adding the MPS to turbulent water. Leave the cover up and jets on high for 10 minutes. Then shut jets off and return the cover to the closed position to maintain heat. Then return the cover to the closed position to maintain heat.

SPA MAINTENANCE

FILTER CARTRIDGE MAINTENANCE

At least once a week, check and clean the skimmer basket and weir to ensure proper filter flow. Remove leaves, foreign matter, and debris. It is very important to keep your spa filter cartridge clean and free of particles to ensure proper water flow. A clean filter permits the hydrotherapy system to function properly and also allows more efficient filter cycles. Depending on how frequently your spa is used, we recommend cleaning the spa filter cartridge every four weeks. If this is not done, the filter may clog and restrict water flow, which causes improper filtration and poor jet performance.

IMPORTANT: The frequency and duration of use, and the number of occupants all contribute to determining the appropriate time between filter cleanings. More use means that more frequent filter cleanings will be required.

FILTER CARTRIDGE REMOVAL AND CLEANING INSTRUCTIONS

1. Press Mode button for 8+ second to OFF.
2. Pull out the basket and weir.
Carefully unscrew the filter cartridge and bring it out of the spa.
3. Always clean the filter using a filter degreaser to remove mineral and oil build-up. Soak the filter in the degreaser (according to the package directions). Then place the filter on a clean surface and, using a garden hose, spray until it is clean. It may be necessary to rotate the filter while spraying to remove any debris lodged between the filter pleats.

4. Replace the cartridge in the spa.
Lower the basket and weir over filter.
5. Turn on power by pressing jets button.

CAUTION! Always use proper eye protection when using chemicals, or high-pressure water. Read instructions on cleaning products and follow applicable safety and warning instructions listed on label.

CAUTION! Never scrub the filter cartridge with a brush, as this will cause the filter to wear out and come apart. Never let the spa pump run without a filter cartridge in the skimmer compartment. Running the spa without a filter cartridge may permit debris to enter the spa plumbing and void the warranty!

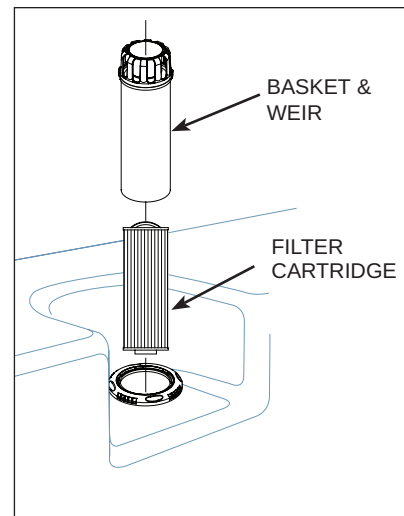

SPA MAINTENANCE

SURFACE CARE

Do not use solvents or abrasive cleaners to clean the spa. Typically, a mild detergent and water will resolve cleaning issues.

COVER CARE

The cover is made with a solution dyed polyester fabric and is an attractive, durable foam insulation product. Monthly cleaning is recommended to maintain its beauty and a longer fabric life.

To clean and condition the polyester cover:

1. Remove and gently lean against a wall or fence. If a cover lifter has been installed keep cover closed and make sure all seams are closed to prevent any soap from entering the spa.
2. With a garden hose, spray the covers to loosen and rinse away dirt or debris.
3. Add four tablespoons of mild soap or mild dishwashing liquid with 4 liters (one gallon) of lukewarm water. Clean using a soft bristle brush. Rinse thoroughly with cold water and air dry.

IMPORTANT: Do not let the polyester

dry with a soap film on it before it can be rinsed clean.

4. Scrub the cover's perimeter and side flaps. Rinse clean with cold water.
5. Rinse off the underside of the cover with water only (use no soap), and wipe it clean with a dry rag.

CABINET CARE

Little maintenance is required to keep your spa cabinet looking good.

Spa cabinet product should be cleaned as needed to remove dirt and debris.

- NO abrasive or harsh chemicals should be used on the spa's cabinet.
- NO solvents or cleaners containing aromatic solvents should be used on the spas cabinet.
- Hot soapy water is the best choice for cleaning the spa's cabinet.

AVOID PROLONGED EXPOSURE TO DIRECT SUNLIGHT OR EXCESSIVE TEMPERATURES 38°C (100°F) to avoid your spa cabinet from buckling.

REPLACEMENT SPA PARTS

PART NUMBER

DESCRIPTION

78825

SPA FILTER – 4.5 sq. meters
(50 sq. ft.)

78894

SPA FILTER – 3.25 sq. meters
(35 sq. ft.) (PLA-34L only)

30700

DRAIN CAP

71515

COVER LOCKS

70322

COVER KEYS

DRAINING OR WINTERIZING

Every three to six months, depending upon the water condition, you need to renew your water.

CAUTION: READ THIS BEFORE DRAINING YOUR SPA

- To prevent damage to the spa's components, **TURN OFF SUBPANEL BREAKER BEFORE DRAINING.** Do not power back up until your spa has been refilled with water.
- There are certain precautions to keep in mind when draining your spa. If it is extremely cold, and the spa is outdoors, freezing could occur in the plumbing or the equipment.
- Do not leave the spa's shell (inside surface) exposed to direct sunlight.

DRAINING YOUR SPA

- a. Route the outlet of the drain hose to an appropriate draining area. Locate the drain (bottom front) of the spa, remove the drain cap and attach the inlet of a



DRAIN CAP

garden hose to drain the spa, (to avoid flooding of the foundation surrounding the spa). **NOTE:** Spa water with a high sanitizer level may harm plants and grass.

- b. Allow all of the water to drain through the drain.
- c. After your spa is empty, clean the shell and filter cartridge. See "Spa Maintenance" section.
- d. After cleaning, reinstall the drain cap.
- e. Follow the "Fill up and Applying Power" instructions on page 15.

WINTERIZING YOUR SPA

If you plan to store your spa for the winter, you must also use a wet-vac to clean out the water lines to ensure they are free of any

water. Water left in the lines might freeze and damage the lines and jets.

- a. It will be necessary to remove all water from the interior plumbing.
- b. Remove the floating weir, basket, and filter cartridge. Clean the filter cartridge and store in a dry place. Attach the vacuum hose to the vacuum side of the shop vac and thoroughly dry the filter compartment.
- c. Using the shop vac, remove the water starting with the jets at the top and moving to the ones at the bottom of the spa. **NOTE:** When removing the water from jet openings, you may notice suction coming from another jet. With the help of a second person, block off any suction from the other jet using a large rag or cloth. This will help pull out the water that is trapped deep inside the main line.
- d. Thoroughly dry the spa shell with a clean towel.
- e. Using a funnel, pour Propylene glycol anti-freeze into the filter suction fittings and jet outlets. **CAUTION:** Use only Propylene glycol as your anti-freeze. This is non-toxic. **NEVER** use automobile anti-freeze since it is toxic.
- f. Remove the pump drain plug located on the front of the pump housings. Allow all water to drain out. Place the drain plug in a reclosable plastic storage bag and store near the pump. Replace the drain plugs on start-up.
- g. Unscrew the suction/discharge pump and heater unions and allow the water to drain. Leave union loose. **NOTE:** Tighten unions before filling spa.
- h. Replace the equipment compartment door and secure with screws.

Note: Damage caused by improper winterizing will not be covered under warranty. You may want to contact Customer Service for complete winterizing instructions.

TROUBLESHOOTING PROCEDURES

In the event the spa is not working the way it should, please first review all the installation and operating instructions in this manual and check the message on the panel display. If you are still not satisfied it is working properly, please follow the appropriate troubleshooting instructions.

CAUTION! WARNING! SHOCK HAZARD! No User Serviceable Parts.

Do not attempt service of the control box. Contact Customer Service for assistance. Follow all owner's manual power connection instructions.

NO COMPONENT OPERATION

Check the following:

1. Is there power to the spa?
2. Is the household circuit breaker tripped?
3. Is the subpanel (220-240V) RCD tripped?
4. If 1 is yes and 2 and 3 are no contact Customer Service for assistance.

PUMP DOES NOT OPERATE, BUT THE LIGHT DOES

Press the *Jets 1 or 2* button:

The pump operates but no water flows to jets. Pump may not be properly primed. This can happen after the spa is drained and refilled. Press the *Jets 1 or 2* button several times, never leaving the motor on for more than 5-10 seconds at-a-time with no water coming of of jets.

POOR JET ACTION

1. Press the *Jets 1* button to make certain the pump is on.
2. Turn the air control valves in one direction to increased jet action.
3. Make sure the water level is half way between top of spa and top of the gray filter ring.
4. Check for dirty filter. Clean, if necessary.
5. Make sure all jets are in the open position.

WATER IS TOO HOT

1. Check desired temperature on topside control.
2. Check for a Diagnostic Message (in Control Panel Operation section).
OH - Overheat (spa is deactivated) DO NOT ENTER THE WATER.

If the spa has overheated you should remove the cover to promote heat reduction. The spa control system should reset itself when the water temperature reduces below 40°C (104°F). When the spa temperature falls below the reset you can push any button on the topside control to reset the control system. If the spa will not reset, then shut off power to the spa and contact your local Dealer.

Under extreme and/or prolonged weather conditions it is possible for the ambient temperature to exceed 41°C (106°F); effecting the water temperature of the spa and causing it to overheat. These conditions could cause the spa sensors to produce an OH message and prevent the usage of your spa during these conditions. The location of your spa should be reconsidered to reduce the outside temperature around the spa. For example, you may need to prevent direct sunlight on any surface of your spa. Regardless, do not enter your spa if the temperature is above 40°C (104°F).

Should checking the above steps fail to correct the problem, please contact your local Dealer.



Telephone 029 2070 5059

All Swim Showroom
Units 3-5 Link Trade Park
Penarth Road
Cardiff
CF11 8TQ

Email: sales@allswimltd.com



www.allswimltd.com



305308.26



305308.26 B (3/26)