

**iGarden**

# **iGarden Swim Jet H Series**

## **User Manual**

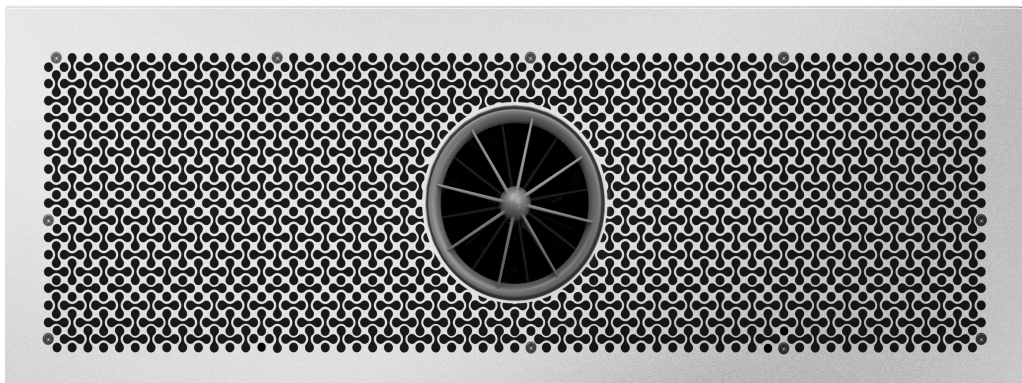

# Content





1. Warnings and Important Safety Instructions .....	2
2. Recommended Installation Environment.....	3
3. Specification .....	4
4. Configurations and Diagram .....	4
5. Installation Process .....	5
6. How to Use Swim Jet.....	14
7. How to Use the Remote .....	20
8. APP Control .....	23
9. Product Care and Maintenance .....	27
10. Failure and Protection .....	27
11. FAQ & Solutions .....	30
12. Disposal .....	30
13. Certification Standards .....	31



# 1. Warnings and Important Safety Instructions

**Please read and follow all instructions before installation:**

Always read this manual and follow all safety instructions before installing or using this product, and keep this manual in a safe place.

## **1.1 When installing and using the Swim Jet, please follow the below safety rules:**

- Check the Jet, controller, and cable wires for signs of damage or wear before use. If any problems are found, stop using the product and contact the dealer for repair or replacement.
- Do not operate the controller without fully understanding the possible consequences of incorrect operation..
- Before power on, make sure that no one is near the inlet and outlet areas of the Jet.
- Avoid placing fragile objects around the Jet.
- To prevent damage to the Jet and to ensure personal safety, avoid exerting pressure on the Jet, such as sitting, straddling, stepping, and other dangerous behaviors.
- It is recommended that swimmers wear swimming caps and goggles during the use of Swim Jet.
- Consult a doctor if you are unwell before use. If you experience chest pain or tightness in the chest, shortness of breath or feel dizzy while using, stop exercising immediately.
- Do not dive near the Jet to avoid unexpected accidents.
- Make sure that there are no obstacles around the Jet and it is fully submerged before powering on.
- This Swim Jet must be powered by a residual current protective device (RCD) with a rated residual action current of not more than 30mA, ensure that it is working properly before each use of the appliance.
- When the Swim Jet is not in use for a long time, please disconnect the power supply.
-  DANGER: Do not insert any foreign objects into the front deflector housing outlet.
-  DANGER: Do not attach any foreign objects such as leaves, pieces of paper, garbage bags and other coverings to the deflector housing outlet.
-  DANGER: Do not run the Swim Jet if there is ice in the pool.
-  DANGER: Stop using this product if the user's body temperature is significantly higher than normal, which may result in serious consequences, including loss of consciousness and risk of drowning.
-  DANGER: Do not put the Jet cable plug into water, and do not plug or unplug the controller plug and the Jet cable plug with wet hands.

-  DANGER: When performing maintenance or overhaul operations on the Jet, the controller must be strictly disconnected to ensure operator safety and to prevent electrical accidents or equipment damage.
-  DANGER: Do not coil the Jet cable for installation to prevent overheating and potential safety risks.

### 1.2 Children safety:

- Do not allow children to use this product without adult supervision.
- Ensure that children are closely supervised at all times while using the product.
-  DANGER: The remote control is for adults only and should be kept out of reach of children.

### 1.3 Restrictions on the use of people:

- Individuals with limited physical/sensory or mental abilities should not use this product unless under the supervision of qualified personnel.
- This product should not be used after the use of alcohol, drugs or medications that affect responsiveness.

## 2. Recommended Installation Environment

- The operating ambient temperature of the controller: 0°C~ 43°C (installed in a dry and non-condensing environment, avoiding exposure to sunlight and rain).
- Recommended installation depth of the Jet (center of Jet from the water surface): 250mm (need to ensure that the Jet is completely immersed in the water)
- Operating water temperature of the Jet: +5°C~ +40°C.

It is the responsibility of the Swim Jet user to provide suitable conditions to ensure the optimum life cycle of the product. To comply with the warranty conditions, we only use the most suitable good quality water for swimming pools.

The following parameters are required for swimming pool water quality:

- pH value: 7.0-7.8
- Chlorine: ≤0.5 mg/l
- Free chlorine: 0.3 mg/l to 2.0 mg/l
- Cyanuric acid: ≤100 mg/l
- Salt concentration: ≤0.4% (4000 ppm)
- Metal content: ≈0 mg/l
- Carbonate hardness: ≥2°dH
- Ozone (O<sub>3</sub>): 0 mg/l

- Total chlorite and chlorate:  $\leq 30$  mg/l
- Oxidation reduction potential (ORP):  $\geq 700$  mV

#### Non-intended use

- Not for use in potentially explosive areas.
- Not suitable for harsh environments (gases, acids, vapours, substances, oils).
- Not for sewage.

### 3. Specification

Swim Jet H Series Specific Technical Parameters				
Model	H100	H160	H200	H240
Supply Voltage	220-240V	220-240V	220-240V	220-240V
Frequency	50/60Hz	50/60Hz	50/60Hz	50/60Hz
Input power	400W	600W	900W	1250 W
Max Input Current	1.6A	2.7A	4.0A	5.7A
Max flow rate	100m <sup>3</sup> /h	160m <sup>3</sup> /h	200m <sup>3</sup> /h	240 m <sup>3</sup> /h
Maximum Outlet speed	2.4m/s	2.9m/s	3.5m/s	4.2 m/s

### 4. Configurations and Diagram

#### 4.1 Configurations

SN	Description	Quantity	Note
①	Swim Jet built-in horizontal housing	1	
②	Jet component	1	
③	Waterproof cable connector	3	
④	Right bracket 2205 duplex stainless steel	1	
⑤	Left bracket 2205 duplex stainless steel	1	
⑥	M10 Hexagonal flange nut 2205 duplex stainless steel	4	
⑦	Hexagon socket head screw M8×20 2205 duplex stainless steel	4	
⑧	Elastic gasket 2205 duplex stainless steel	4	
⑨	Flat washer 2205 duplex stainless steel	4	
⑩	Horizontal built-in gasket EPDM	1	
⑪	Horizontal built-in flange 2205 duplex stainless steel	1	

⑫	Cross groove flat head self tapping screw	32	M6*40 Thickness of pool wall 8-15mm  M6*30 Thickness of pool wall 2-5mm
⑬	Swim Jet built-in horizontal Front cover ASA	1	
⑭	Cross groove countersunk head screw M5×14	12	
⑮	Swim Jet horizontal built-in tooling board Hot dip galvanized DX510	1	

## 4.2 Diagram

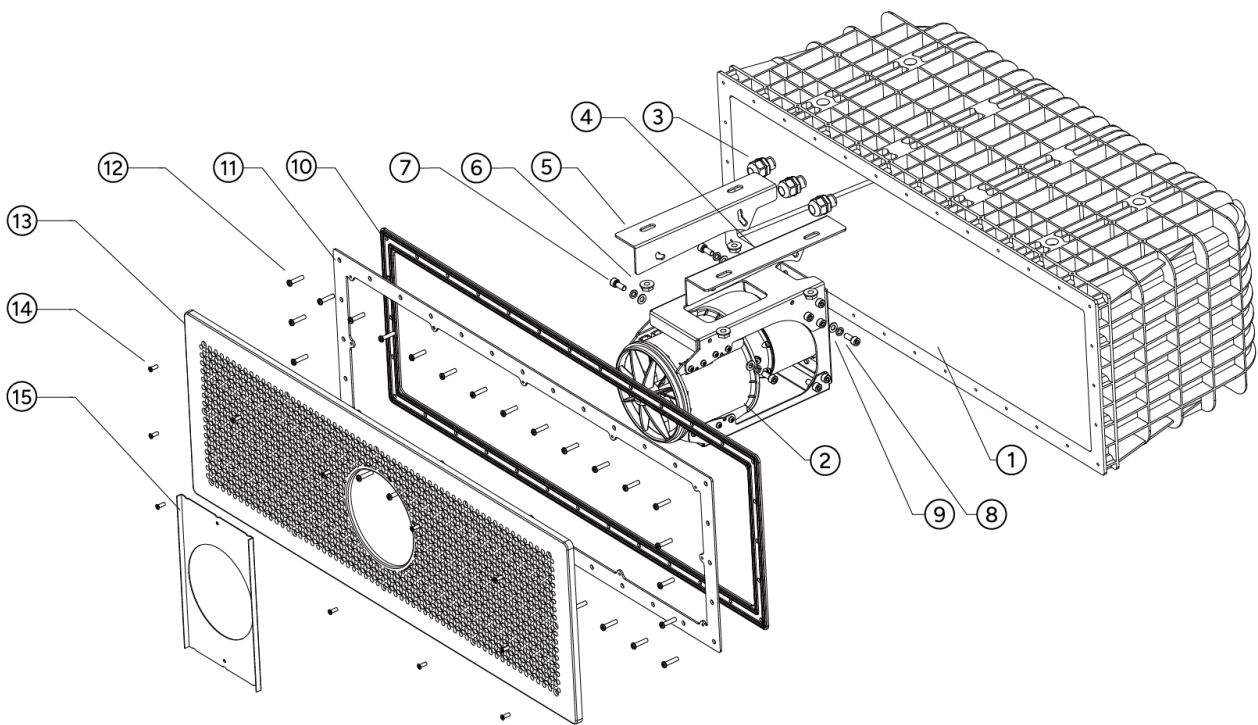

## 5. Installation Process

### 5.1 Swim Jet structure diagram

#### 5.1.1 Built-in housing structure diagram

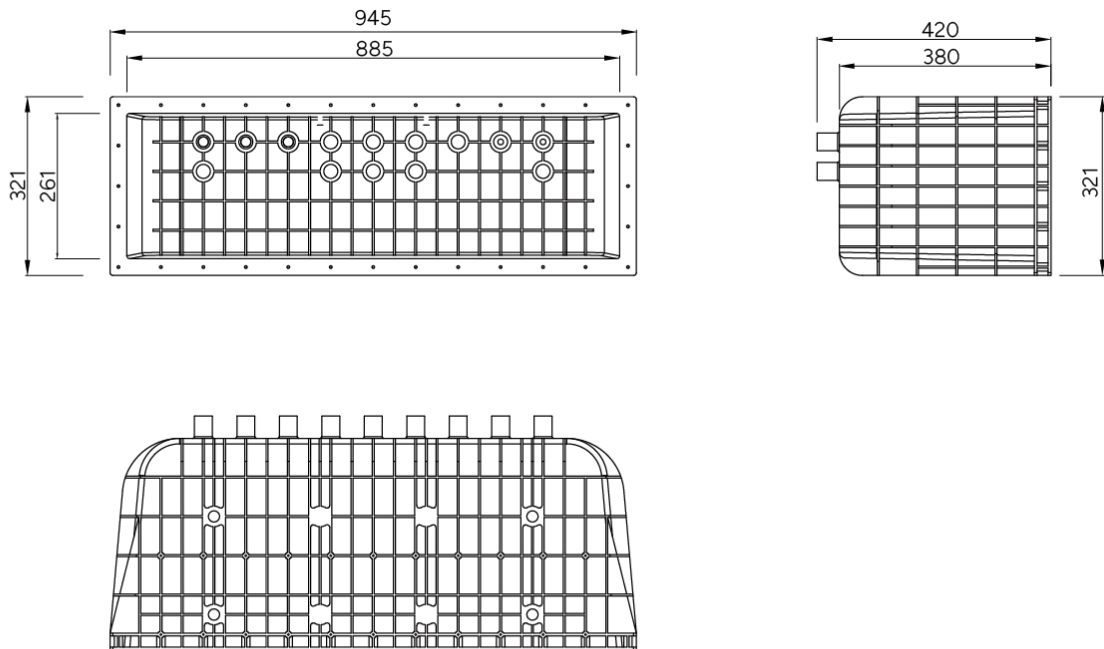

### 5.1.2 Front cover structure diagram

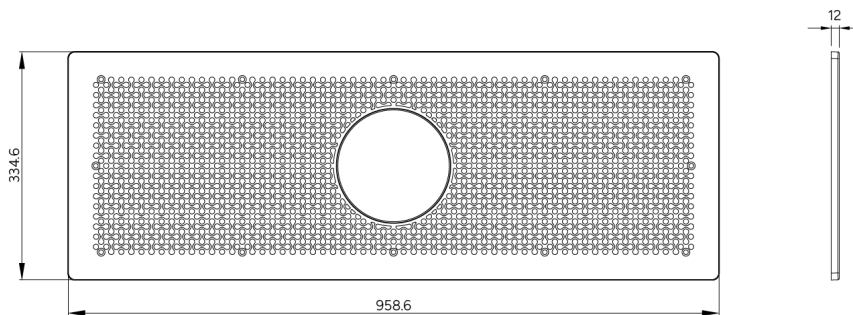

### 5.1.3 Precautions for installing the Jet:

Installation location and depth requirements:

- Installation depth: 250 mm below the water level (the distance between the center of the main unit and the water surface).
- Installation location: It needs to be installed horizontally in the center of the swimming pool wall.

## 5.2 Controller and Control panel Installation

### 5.2.1 Controller structure diagram

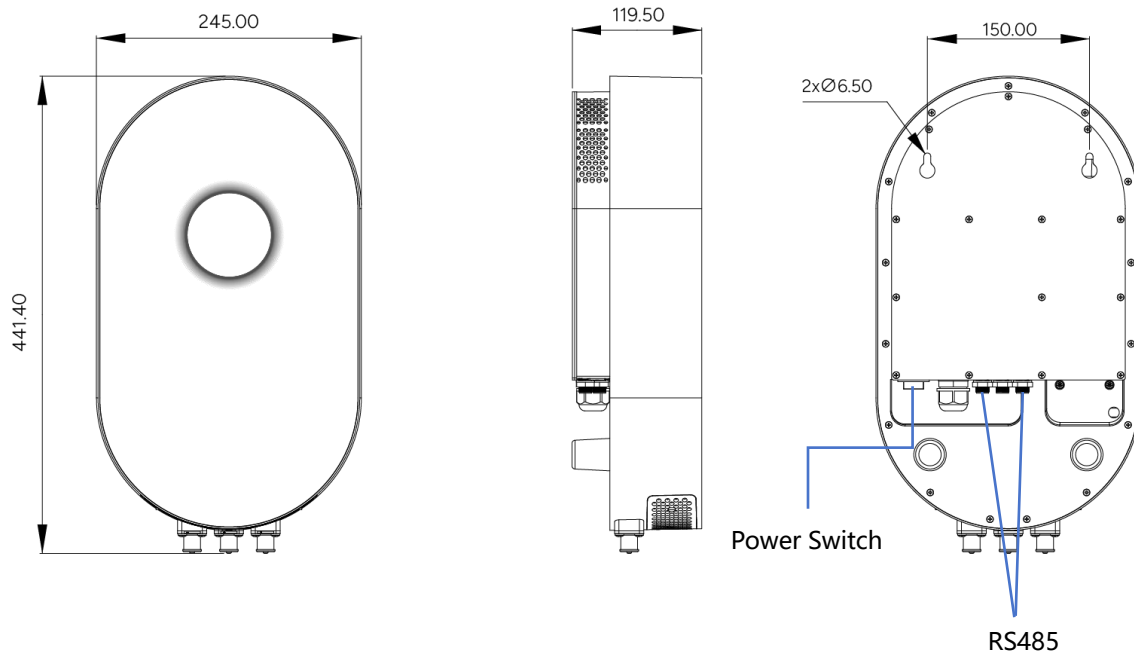

### 5.2.2 Precautions for installing the controller:



**DANGER:** Ensure that the controller is turned off before installation to avoid injury from accidental startup;

Installation environment:

- Ensure that the controller is installed at least 3 meters from the edge of the pool
- The controller should be located in a well-ventilated, dry, non-condensing area, protected from the direct effects of rain and pool splash.
- For controller installed outdoors, it is recommended that additional shields be added for protection.
- Cable entry holes should face downwards to ensure waterproofing.
- To ensure adequate heat dissipation, keep a space of at least 30 cm around the controller.

### 5.2.3 Control panel structure diagram

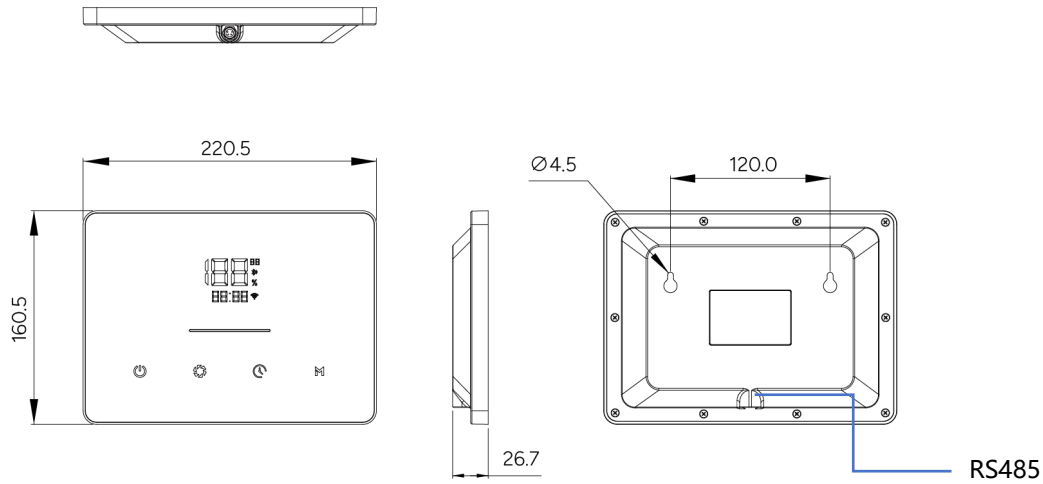

#### 5.2.4 Precautions for installing the control panel :



DANGER: Ensure that the controller is turned off before installation to avoid injury from accidental startup;

Installation environment:

- The controller installation should comply with Zone 2 safety area requirements.
- The controller should be located in a well-ventilated, dry, non-condensing area, protected from the direct effects of rain and pool splash.
- Cable entry holes should face downwards to ensure waterproofing.
- Make sure the control panel and controller are connected correctly to ensure the normal operation of the Swim Jet. If you only complete the controller connection part without connecting the control panel in place, the Swim Jet will not start and operate properly.

#### 5.3 Installation instruction diagram

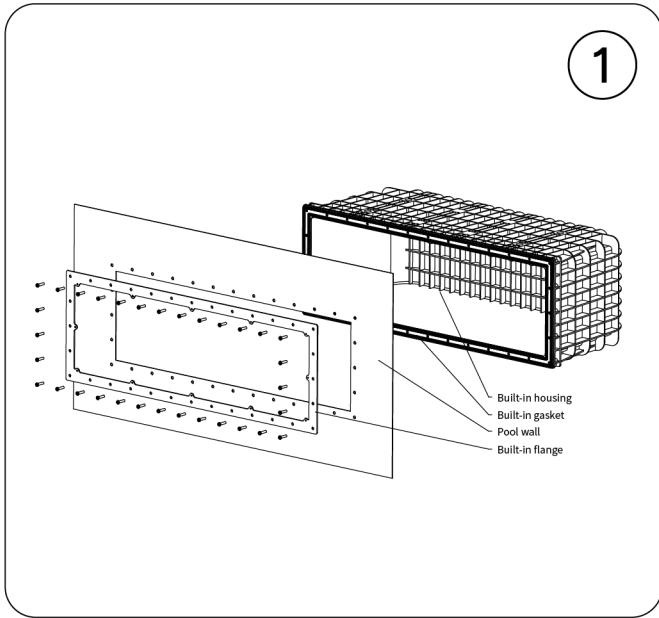

① Install the Built-in housing into the pool

- (1) Place the Built-in housing in the reserved installation position of the pool.
- (2) Select the M6 cross-recessed self-tapping screws of appropriate length according to the material of the pool wall.
- (3) Place the Built-in housing in sequence → Built-in gasket → pool wall → Built-in flange, and tighten diagonally and crosswise according to the hole positions as shown in the figure until fully locked to ensure that the gasket is evenly pressed.

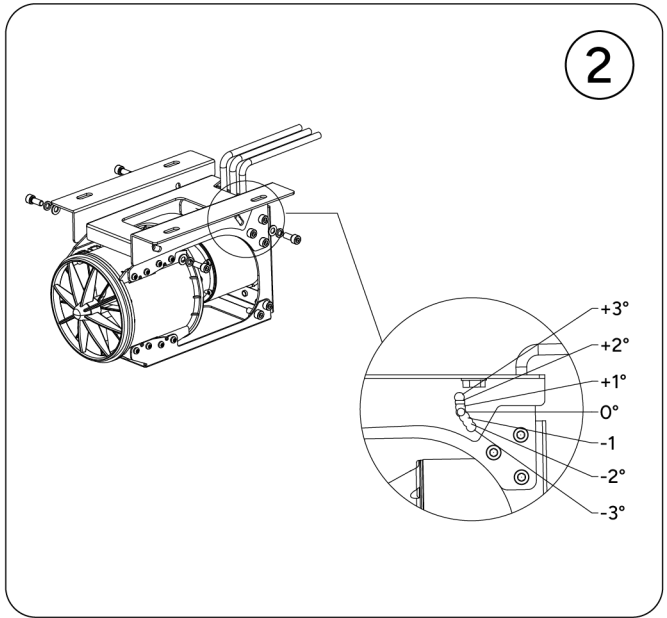

① Install the Jet bracket

- (1) Use the M8 × 20 hexagonal pan head screws to pre-tighten the mounting bracket and the host (this step is not complete tightening).
- (2) Correct the level of the host by adjusting the installation position of the M8 screw. The adjustable range is ±3°.

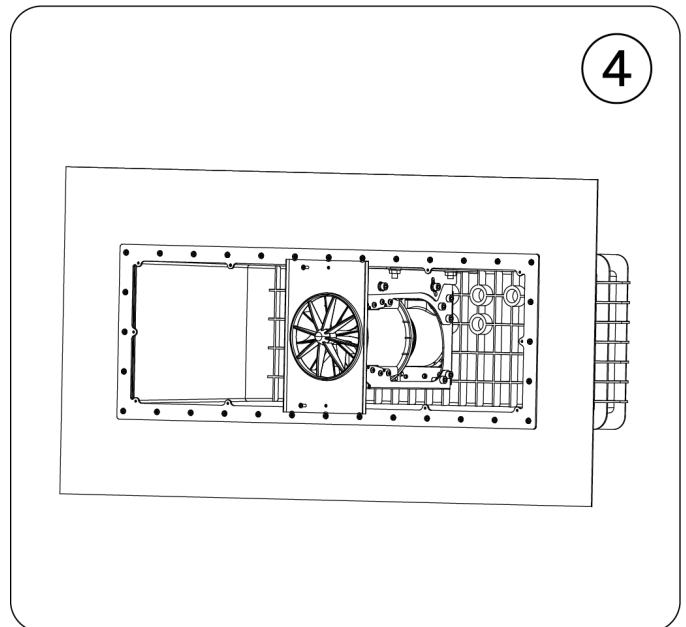
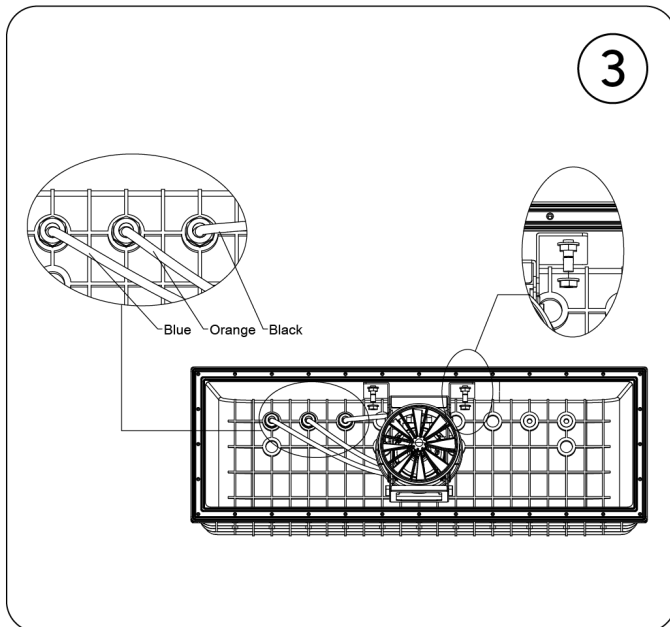

③ Install the Jet into the Built-in housing

(1) Threading: Thread the Jet cable through the Built-in housing. The colors and markings from left to right are: blue (W), orange (V), and black (U).

(2) Use the M10 hexagonal nuts to pre-tighten the host and the embedded box (keep it fine-tuned forward and backward, but do not tighten it completely yet).

④ Use the tooling plate to adjust and fix the Jet

(1) Install the tooling plate with the M5 × 14 countersunk head screws.

(2) Fine-tune the position of the Jet front and back to ensure that the front end of the grille of the Jet assembly passes through the tooling plate smoothly and is pressed tightly.

(3) After the position is confirmed, completely tighten the M8 screws and the M10 nuts that fix the Jet in sequence, and then remove the tooling plate.

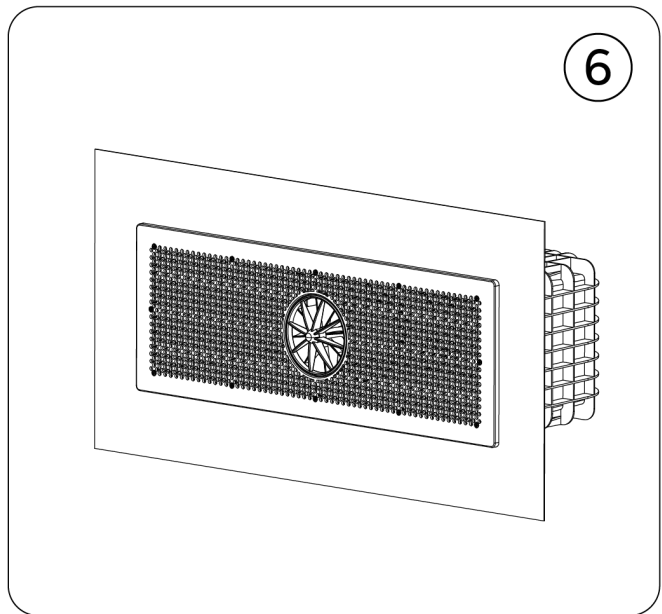
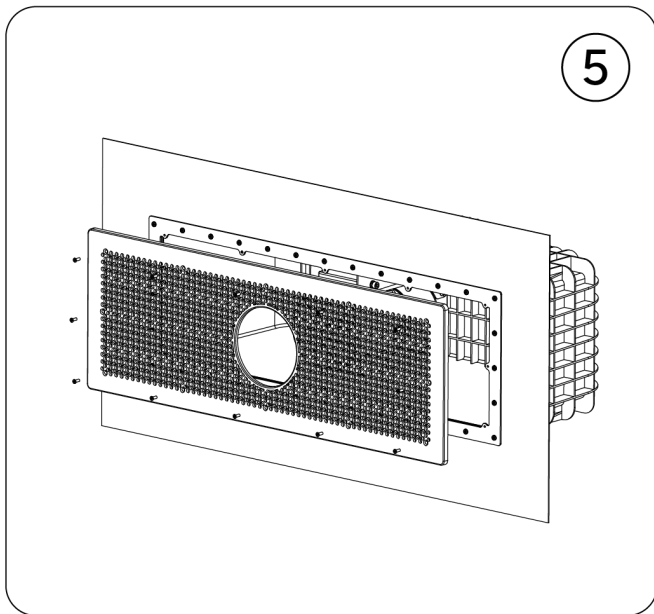

⑤ Install the front cover

(1) After removing the tooling plate, use the M5 × 14 cross-recessed countersunk head screws to install the front cover, keeping it flush with the pool wall and with even gaps.

⑥ Instructions for completion of installation of the Jet

All components of the equipment (1. Built-in housing, Built-in flange, front cover) are installed flush, without steps or gaps. The levelness of the Jet meets the requirements, and the center distance from the water surface is 250mm.

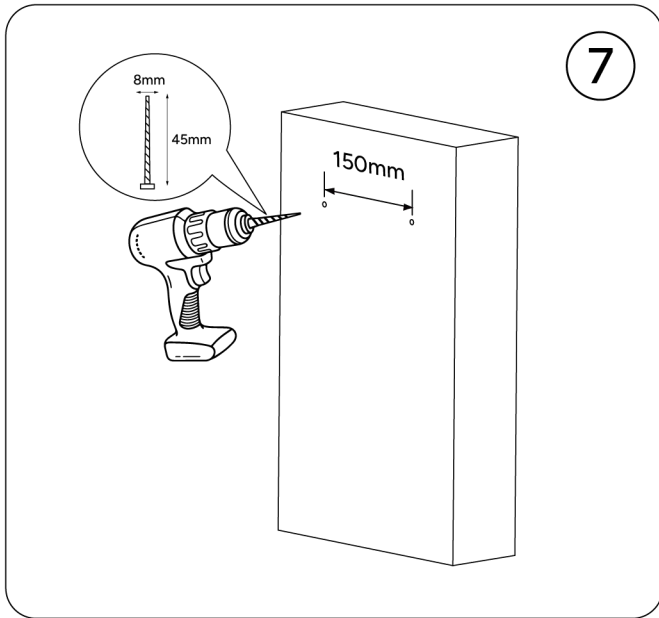

⑦ Drill mounting holes (for fixing the controller)

- (1) Drill 2 holes horizontally in the wall, 150mm apart.
- (2) Recommended drill diameter 8mm, hole depth 45mm.

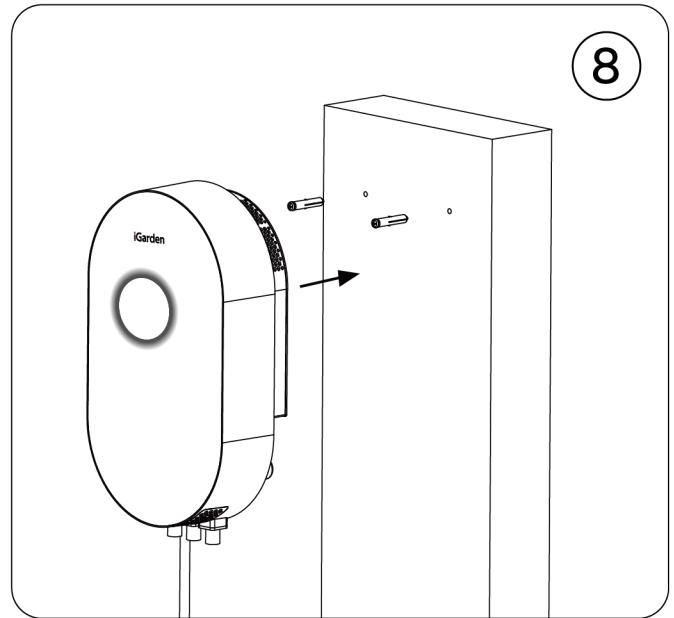

⑧ Fixed the controller

- (1) Install the expansion tube in the drilled hole and screw in the self-tapping screws.
- (2) the controller can be aligned with the holes to hang.
- (3) pay attention to the direction of installation to ensure that the cable jacks is underneath.

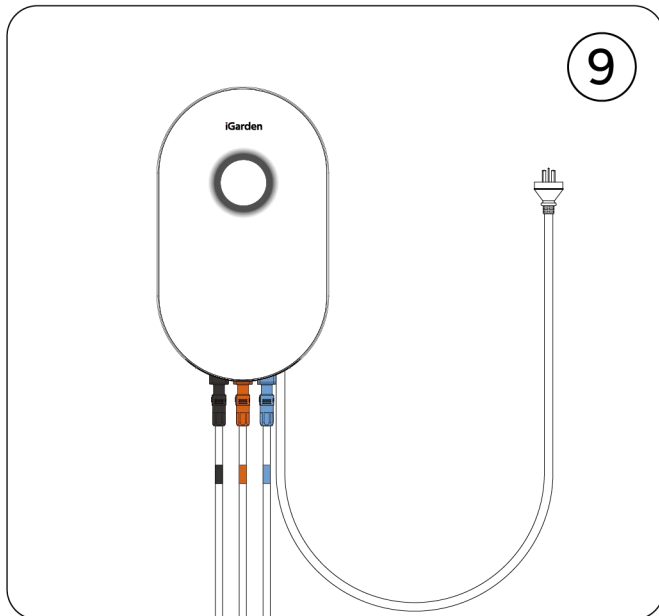

⑨ Wiring between Jet and controller

- (1) Connect the cables of the Jet and the socket of the controller in one-to-one correspondence according to color: Black (U) / Orange (V) / Blue (W).
- (2) After plugging, confirm that the connector is firm and not loose.

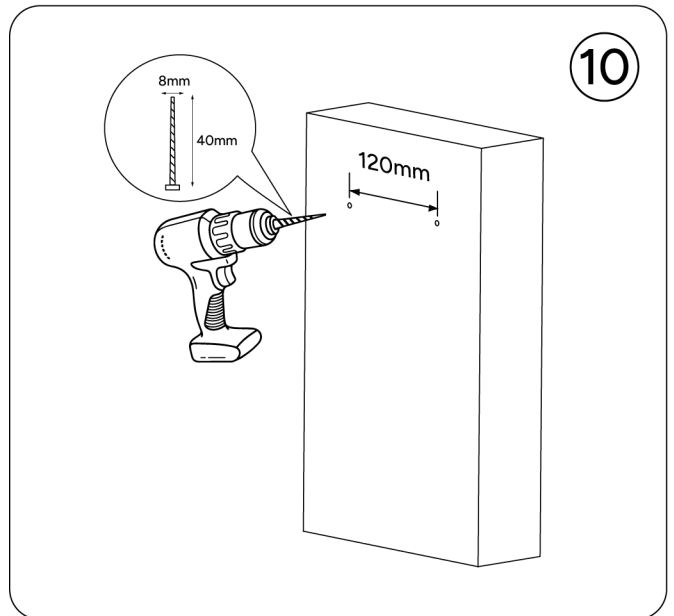

⑩ Drill mounting holes (for fixing the control panel)

- (1) Drill 2 holes horizontally in the wall, 120mm apart.
- (2) Recommended drill diameter 8mm, hole depth 40mm.

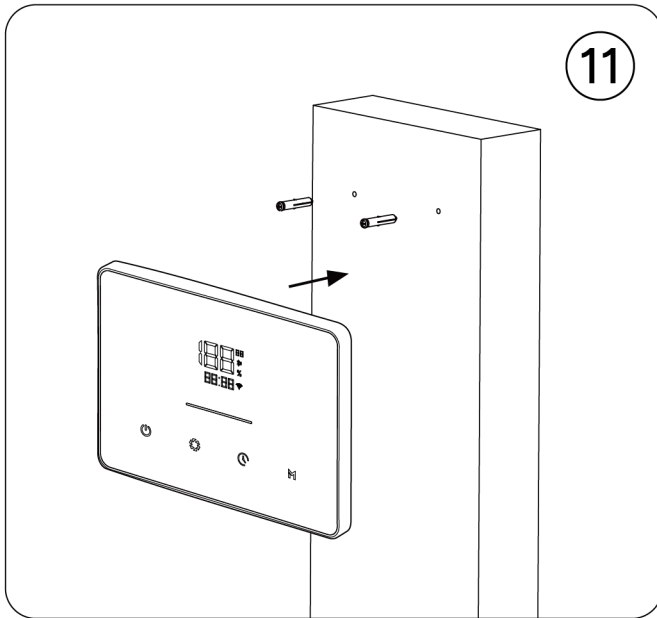

11

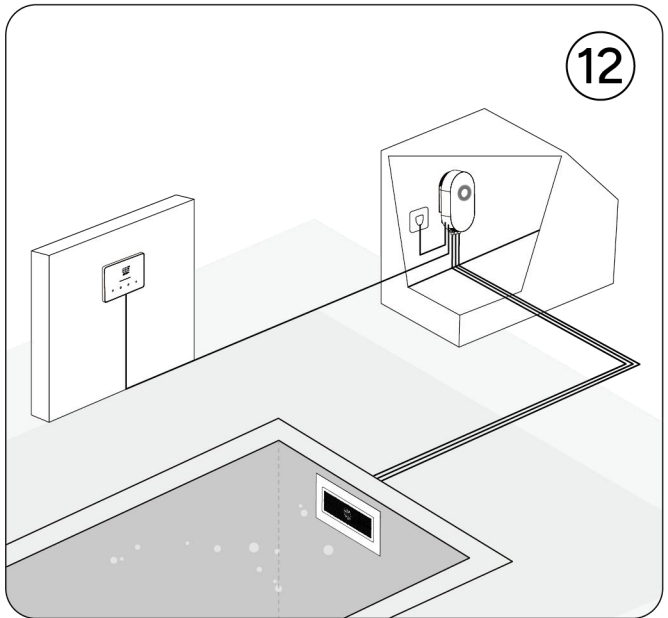

12

⑪ Install the control panel

(1) After installing the expansion tube and self-tapping screws respectively.

(2) Align the screw positions and hang the control panel in place.

Installation direction requirements: The cable socket faces downwards.

Then connect the control panel cable to the RS485 socket of the power box, confirm that the connection is stable, and complete the installation.

⑫ Schematic diagram of the installation of the Swim Jet

As shown in the figure, the Swim Jet installation has been completed:

The Jet is firmly installed in the pool wall, the controller and control panel are firmly fixed on the wall, the wiring is neatly connected, and the sockets are in the correct direction and all face downwards.

5.4 Installation of underwater switch (optional)

5.4.1 Underwater switch structure diagram

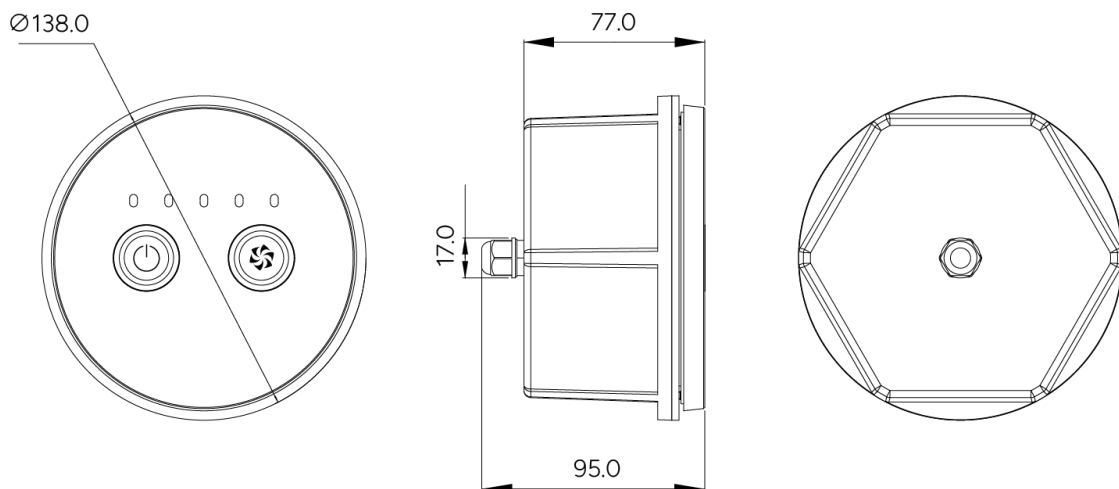

### 5.4.1 Underwater switch explosion diagram

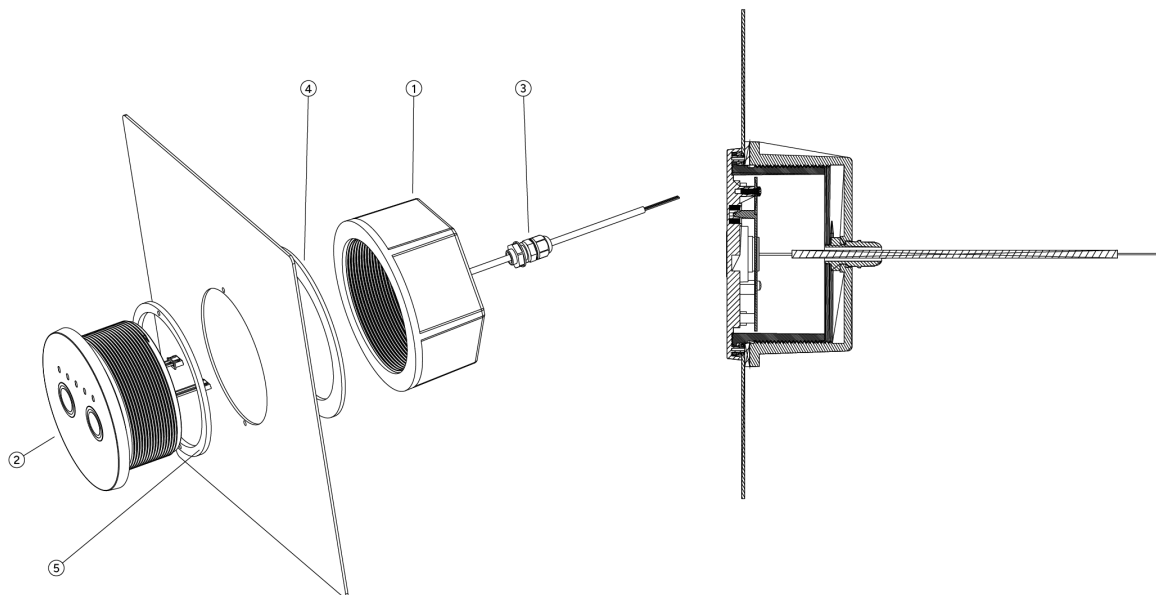

### 5.4.1 Underwater switch configuration

SN	Description	Quantity
①	Underwater switch housing $\varnothing$ 140*63mm ABS	1
②	Underwater switch panel $\varnothing$ 130*60mm ABS	1
③	Waterproof cable connector M12	3
④	gasket $\varnothing$ 138*3mm EPDM	1
⑤	gasket $\varnothing$ 124*4.2mmsilicon rubber	1

### 5.4.4 Underwater switch installation instructions

#### 1. Hole opening and positioning

Open a  $\varnothing$  111 mm through hole on the swimming pool wall; drill two  $\varnothing$  4 mm positioning holes in the vertical direction of the hole center, with a distance of 117 mm (the positioning holes must be vertical, otherwise they will be installed crookedly, and the connection line between the positioning holes passes through the center of the circle of  $\varnothing$  111).

#### 2. Panel component entry hole

Install the ⑤ gasket into the ② underwater switch panel, insert the component into the through hole, and ensure that the positioning posts on ② accurately enter the two positioning holes.

#### 3. Shell and seal

Put the ④ sealing gasket into the ② panel; pass the cables through the ③ M12 waterproof connector ( $\times$ 3) on ① from the inside to the outside.

Screw the ① shell into the ② panel and lock it, then tighten the ③ waterproof connector and check that the two seals (④, ⑤) fit well.

#### 4. Wiring

The cables are connected to the power box through quick connection terminals. The underwater switch cable is 3 m; the electrical box communication line is 27 m by default. The external communication line 2 of the embedded underwater switch is plugged into the corresponding RS485 interface of the power box.

#### 5. Check

Confirm that the appearance level is not skewed, the connectors are tightened, and there is no risk of cable pinching or water seepage; conduct a simple continuity/function test.

### 6. How to Use Swim Jet

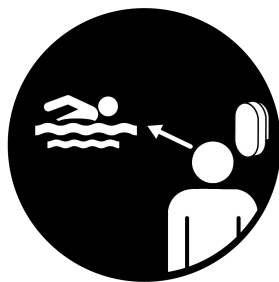

#### 6.1 Check before usage

##### a. Check the power supply and connections;

- Make sure the power is off.
- Check the cables: check that all cables are connected correctly and are not damaged or worn, if damage occurs, do not use the product and contact the agent for repair.

##### b. Check the Jet and pool condition

- Make sure the Jet is fully submerged.
- Clear obstacles: check that there are no obstacles in the pool, especially near the Jet, to ensure that there is no interference with the operation of the Jet.

##### c. Safety check

- Earth leakage protection: Confirm that the residual current device (RCD) is working properly.
- Wear a swimming cap and goggles.

##### d. Operation preparation

- Operation check: Before start-up, make sure there is no one near the Jet; keep watching the Swim Jet while you start it.

- Controller panel: Check the controller panel to see if there is any damage or cable loosen.



**e. Usage tips:**

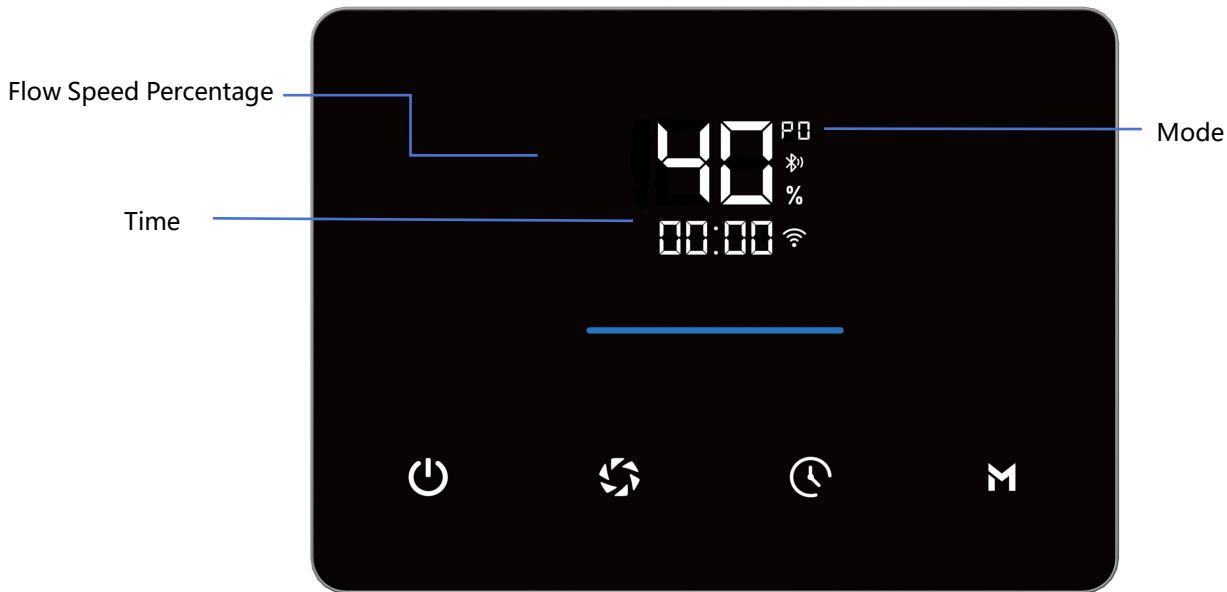

-  DANGER: Do not plug or unplug the power plug with wet hands to prevent electric shock.
- Keep safe distance: Maintain a safe distance of at least 50 cm from the Jet during operation.

**f. After confirming the above safety, the user can power on the power operation**

**6.2 Touch button description**





Name	Function	Description
	1、 Power on	The control panel and the controller are connected normally. After the controller is powered on, press and hold the ON/OFF Button for 2 seconds to power on. The Jet will default to free mode upon startup.
	2、 Power off	Hold for 2 seconds to power off. The memory flow rate will be saved before shutting down and will be used by default when the Jet is turned on next time.
	3、 Pause	Quick click pause while the mode is running. If there is no operation for 30 minutes in the pause state, the system will automatically shut down.
	4、 Resume	Quick click in the paused state to resume the pre-paused state.
MODE 	1、 Switch mode	Tap to switch to different modes, Free Mode(P0), Training Mode(P1-P4) and Surfing Mode(P5).
TIMER	1、 Enter timer	Quick click to enter timer mode.

	2、 Adjust different timer	Tap the TIMER button to adjust, there are six timers:15min, 30min, 45min, 60min, 75min, 90min.
SPEED 	1、 Adjust speed	Click the SPEED button to switch the flow speed, there are five speeds: 20%, 40%, 60%, 80%, 100%

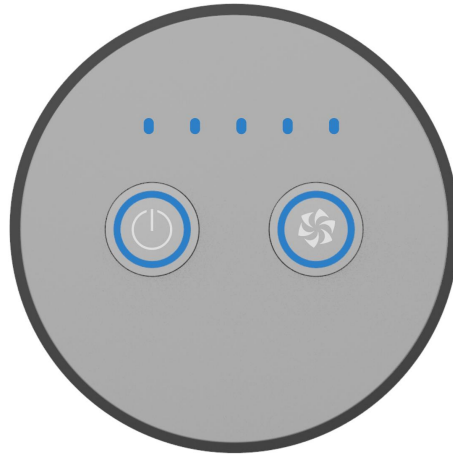
### 6.3 Underwater switch (optional) button description



Name	Function	Description
ON/OFF 	1、 Power on	The control panel and the controller are connected normally. After the controller is powered on, press and hold the ON/OFF Button for 2 seconds to power on. The Jet will default to free mode upon startup.
	2、 Power off	Hold for 2 seconds to power off. The memory flow rate will be saved before shutting down and will be used by default when the Jet is turned on next time.
SPEED 	1、 Adjust speed	Click the SPEED button to switch the flow speed, there are five speeds: 20%, 40%, 60%, 80%, 100%. When the flow rate changes, the gear position will change with the speed change. 20% corresponds to 1 light, 40% corresponds to 2 lights, and so on.

### 6.4 Controller display instructions

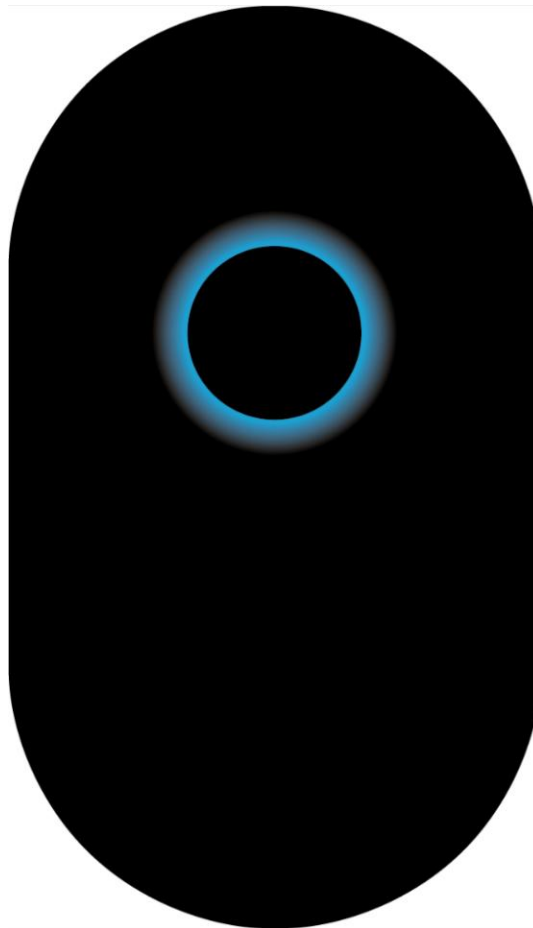

Controller aperture color	Status	illustrate
White	Standby state	Including shutdown, pause, menu settings and other states
Blue	Start state (motor on)	Indicates that the device is running
Red	Fault status	Indicates that there is an abnormality or failure in the equipment

## 6.5 Mode description

### 6.5.1 Mode introduction

Mode Type	P0(Free)	P1(Beginner)	P2(Intermediate)	P3(Advanced)	P4(Endurance)	P5(Surfing)
Duration	Optional	15mins	20mins	25mins	30mins	Optional
Percentage of speed range	20% - 100%	20% - 35%	45% - 70%	70% - 85%	45% - 65%	30% - 100%

Inverter Speed	H240: 1.4m/s~4.2m/s H200: 1.4m/s~3.5m/s H160: 1.4m/s~3.0m/s	H240: 1.4m/s~1.9m/s H200: 1.4m/s~1.8m/s H160: 1.4m/s~1.7m/s	H240: 2.3m/s~3.2m/s H200: 2.0m/s~2.7m/s H160: 1.9m/s~2.4m/s	H240: 3.2m/s~3.7m/s H200: 2.7m/s~3.1m/s H160: 2.4m/s~2.7m/s	H240: 2.3m/s~3.0m/s H200: 2.0m/s~2.6m/s H160: 1.9m/s~2.3m/s	H240: 1.8m/s~4.2m/s H200: 1.6m/s~3.5m/s H160: 1.5m/s~3.0m/s
Feature	Supports manual setting of flow rate levels (20%, 40%, 60%, 80%, 100%), with no time limit, suitable for daily relaxation or technical practice.	Low speed fluctuations with intermittent changes in flow rate, suitable for beginners and recovery training.	The flow rate remains at a moderate level with intermittent changes, ranging from 45% to 70%, with more obvious alternations between strong and weak wave.	The flow rate is continuously at a high level, with intermittent changes, ranging from 70% to 85% with greater wave	Endurance training, focusing more on the continuity of swimming training.	The flow rate switches quickly, simulating a real surfing experience

Note: In surfing mode, the water flow changes at a high rate and has a certain impact force. Users are advised to wear appropriate swimming equipment, such as swimming rings, floating sleeves, back floats, etc., while wearing a swimming cap and goggles to ensure safety.

### 6.3.2 Mode flow speed details

Swim Jet has 6 modes, free mode (P0), training mode (P1, P2, P3, P4), surfing mode (P5). You can switch between different modes by clicking the MODE button .

P0(Free):

Duration	Optional
Inverter Speed	20%, 40%, 60%, 80%,100%

P1(Beginner):

Duration	0-2min	3-5min	6min	7-9min	10min	11-13min	14-15min
----------	--------	--------	------	--------	-------	----------	----------

Inverter Speed	20%	30%	20%	35%	20%	30%	20%
----------------	-----	-----	-----	-----	-----	-----	-----

P2(Intermediate):

Duration	0-3min	4-6min	7-8min	9-12min	13min	14-17min	18-20min
Inverter Speed	45%	55%	45%	70%	45%	55%	45%

P3(Advanced):

Duration	0-5min	6-9min	10min	11-14min	15min	16-20min	21-25min
Inverter Speed	70%	80%	70%	85%	70%	80%	70%



P4(Duration):

Duration	0-7min	8-24min	25-30min
Inverter Speed	45%	65%	45%

P5(Surfing):

Duration	Optional
Inverter Speed	Surfing Wave

## 6.4 Speed adjustment

Click the SPEED button  to switch the speed in sequence (20%/40%/60%/80%/100%). In training modes P1~P4, click the SPEED button  can change the speed, but it is only valid for the current time period and will not affect the entire training plan.

Note: In Surfing mode, the speed cannot be adjusted.

## 6.5 Timing setting

Click the TIMER button  to enter the setting state, click again to select the training time (15/30/45/60/75/90 minutes), and you can also select 5 flow speeds (20%/40%/60%/80%/100%). The timer mode will automatically start after 3 seconds of no operation, and the time will start to count down. After the countdown ends, the running time and speed will flash, and then enter the free mode. The speed can be adjusted at any time during the timer mode.

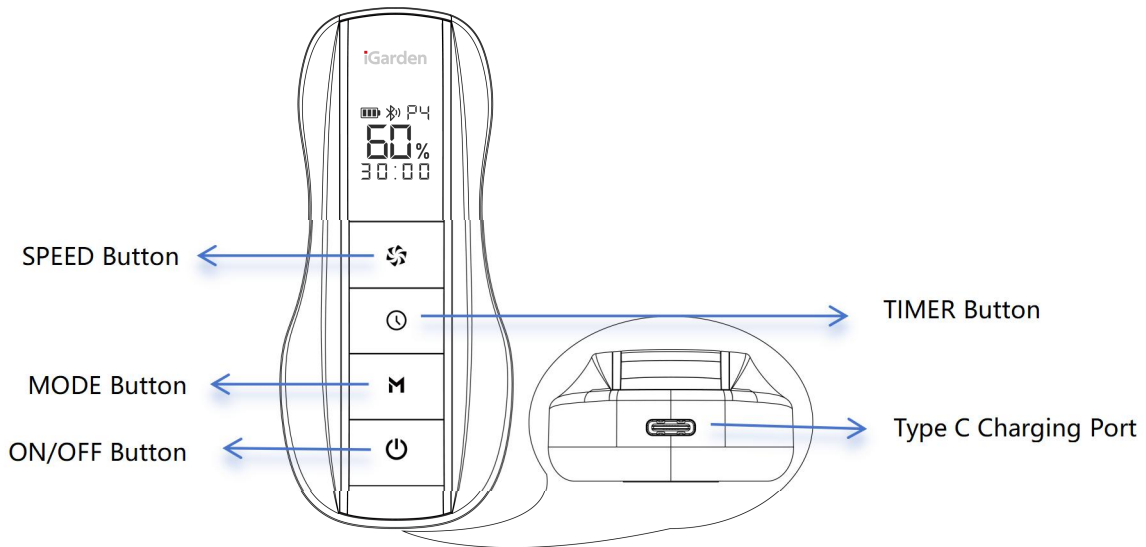

Press the MODE button  switch to exit timer mode , this is also applies to other operating modes.

## 7. How to Use the Remote



### 7.1 Power On

#### 7.1.1 Operating Steps

- In the powered-off state, press and hold the Power On/Off button  for 2 seconds. The remote screen will light up and display  .
- After successful Bluetooth pairing, the screen will synchronize and display real-time information from the controller (e.g., current flow rate intensity, operating time, current mode, Bluetooth connection status).

#### 7.1.2 Remote Placement

- The remote can be magnetically attached to the right side of the controller and the wire upper cover. Both locations have dedicated magnetic attachment points and are marked with stickers for easy identification and placement.

#### 7.1.3 Bluetooth Connection Error Handling

- If the Bluetooth connection fails, the screen will freeze on the current interface, and the Bluetooth icon will flash rapidly, indicating that the device cannot be controlled. At this time, move closer to the controller (signal source) to allow automatic Bluetooth reconnection. Once connected, the controller' s interface information will be displayed synchronously.
- When powered on, the remote' s button operations function the same as the controller, and their information remains synchronized in real time.

#### 7.1.4 Transmission Range Description

- The effective Bluetooth transmission range between the remote and the controller is 20 meters( $\leq 20$  meters) (in an ideal unobstructed environment-there is no obstruction between the remote and the controller). Actual range may be reduced due to obstacles or signal interference. It is recommended to keep the devices within line of sight during use.

### 7.1.5 Water ingress treatment

- Water ingress treatment: If the remote falls into the swimming pool, take it out as soon as possible and follow the steps below to handle it.

1. Shake off water: Gently shake the remote (opening facing downward) to remove water from ports/gaps.

2. Wipe the surface: Use a dry cloth to absorb moisture from the casing, charging port, etc.

**Note:** Do not turn on or charge the device if there is any residual moisture, and do not use high temperature drying.

## 7.2 Power Off

### 7.2.1 Operating Steps

- Press and hold the Power On/Off button  for 2 seconds until the screen turns off.
- If the controller is on, turning off the remote will also trigger the controller to shut down.

## 7.3 Power Management

The power status display bar has 3 battery grids. Please charge in time when the power is low (only one grid left).

**a. Charging method:** Please use the Type-C charging cable for charging. Plug one end of the charging cable into the charging port of the remote (the bottom directly below the remote) and the other end into the power adapter. Make sure the charging cable is firmly connected.

**b. Charging process:** During the charging process, the power status display bar will show the charging progress. When the battery is fully charged, the charging indicator will show the full power grid.

**c. Charging temperature:** Do not charge in high or low temperature environments. The charging environment temperature range is: 0~45°C.

**d. Continuous charging time:** The battery cannot be charged continuously for more than 24 hours.

## 7.4 Storage Requirements

To ensure the performance and life of the remote, please store it within the following temperature range:



- Short-term storage (within 1 month): -20°C to 45°C.
- Medium-term storage (within 3 months): -20°C to 35°C.
- Long-term storage (within 1 year): -20°C to 25°C.

**Note:** If the remote is stored for more than 3 months in the factory state, it is recommended to charge it once, and the





charging capacity can be maintained at 75% (2 grids) to keep the battery healthy.

## 7.5 Bluetooth Re-Pairing

If you replace the remote or controller, you must re-pair them according to the following instructions:

- Before replacing the new remote, make sure that the old remote is not within the effective signal range, or clear the pairing information of the old remote.
- Clearing the pairing information of the old remote: With the controller turned off, press and hold the MODE button  + TIMER button  simultaneously for 2 seconds to clear the pairing information of the remote.

### Pairing steps:

- a. After powering on the supply unit, press and hold the MODE button  + TIMER button  for 2 seconds to enter Bluetooth pairing mode.
  - b. Ensure the remote is within the transmission range (20m).
  - c. On the remote, press and hold the MODE button  + TIMER button  for 2 seconds to enter pairing mode. During pairing, the Bluetooth icon flashes slowly. Once paired, the icon stays lit. If pairing fails within 1 minute, the icon flashes rapidly again.
- If pairing is not completed within 1 minute, the Bluetooth icon will return to the rapid flashing state.

## 7.6 Product specifications

- Communication method: Bluetooth BLE
- Battery type: lithium battery
- Charging interface: Type-C
- Operating temperature: -20-60 °C
- Storage temperature: -20-60 °C

## 8. APP Control

### 8.1 APP Download

Please search “**iGarden**”  in the application market to download.

- Android users: You can search and download through the **Google Play**  application market.

- For iOS users, you can search and download through the **App Store**.



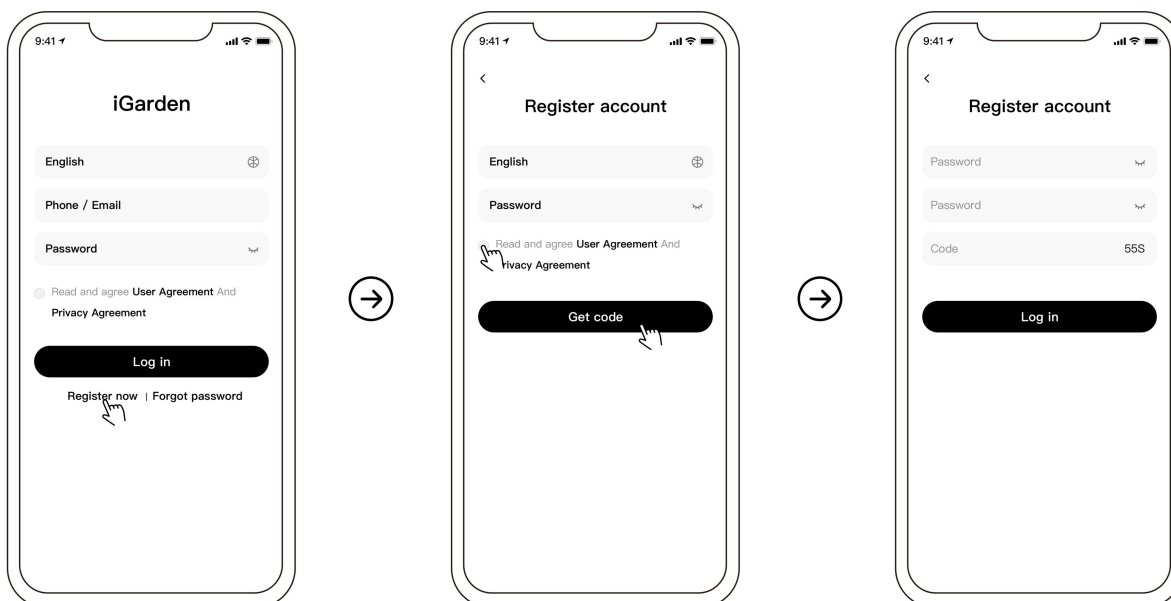

### 8.2 Account Registration and Login

After downloading, you can register and log in your account by **email** or **phone number**.



### 8.3 Adding devices and networking

#### 8.3.1 Bluetooth Networking Mode

1. After the controller is turned on, press and hold  and  at the same time for about 2 seconds until the Wi-Fi icon flashes, and then it enters the network mode.
2. Open **iGarden APP** and click “Add Device” button.
3. Follow the APP instructions to complete the device connection, then your device will be displayed in Home **-My Garden**.

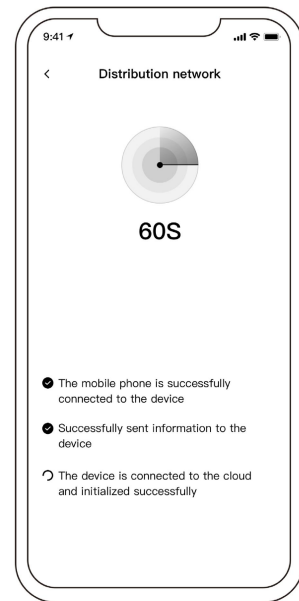
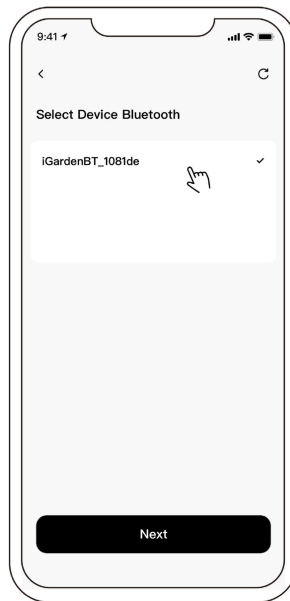
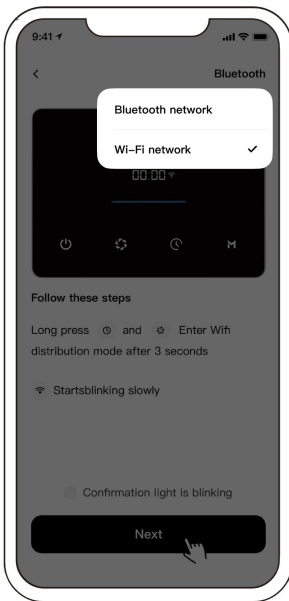
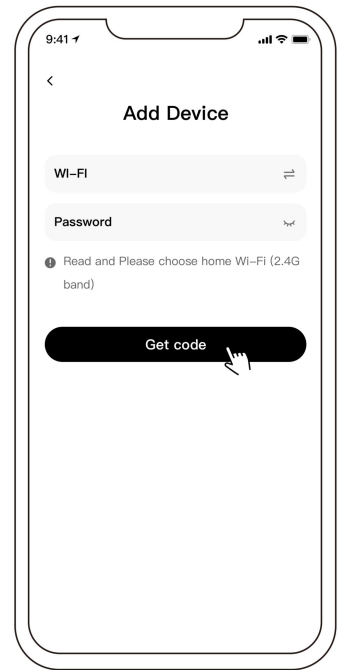
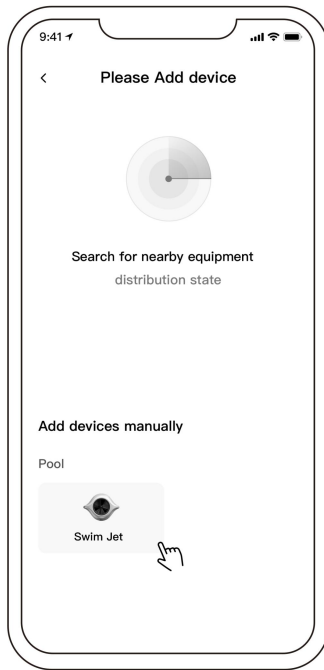
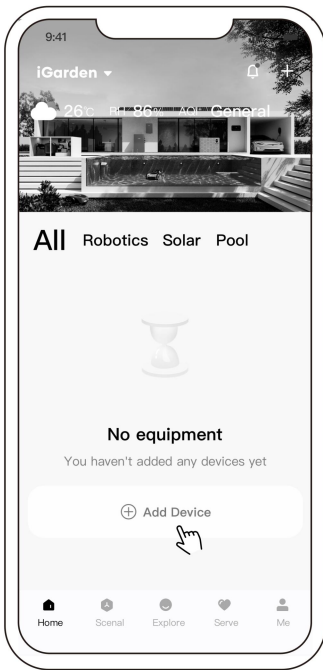

### 8.3.2 WiFi Hotspot Networking Mode

The operation is the same as the Bluetooth mode, select **“WiFi hotspot”** mode to operate, and follow the prompts to complete the connection.

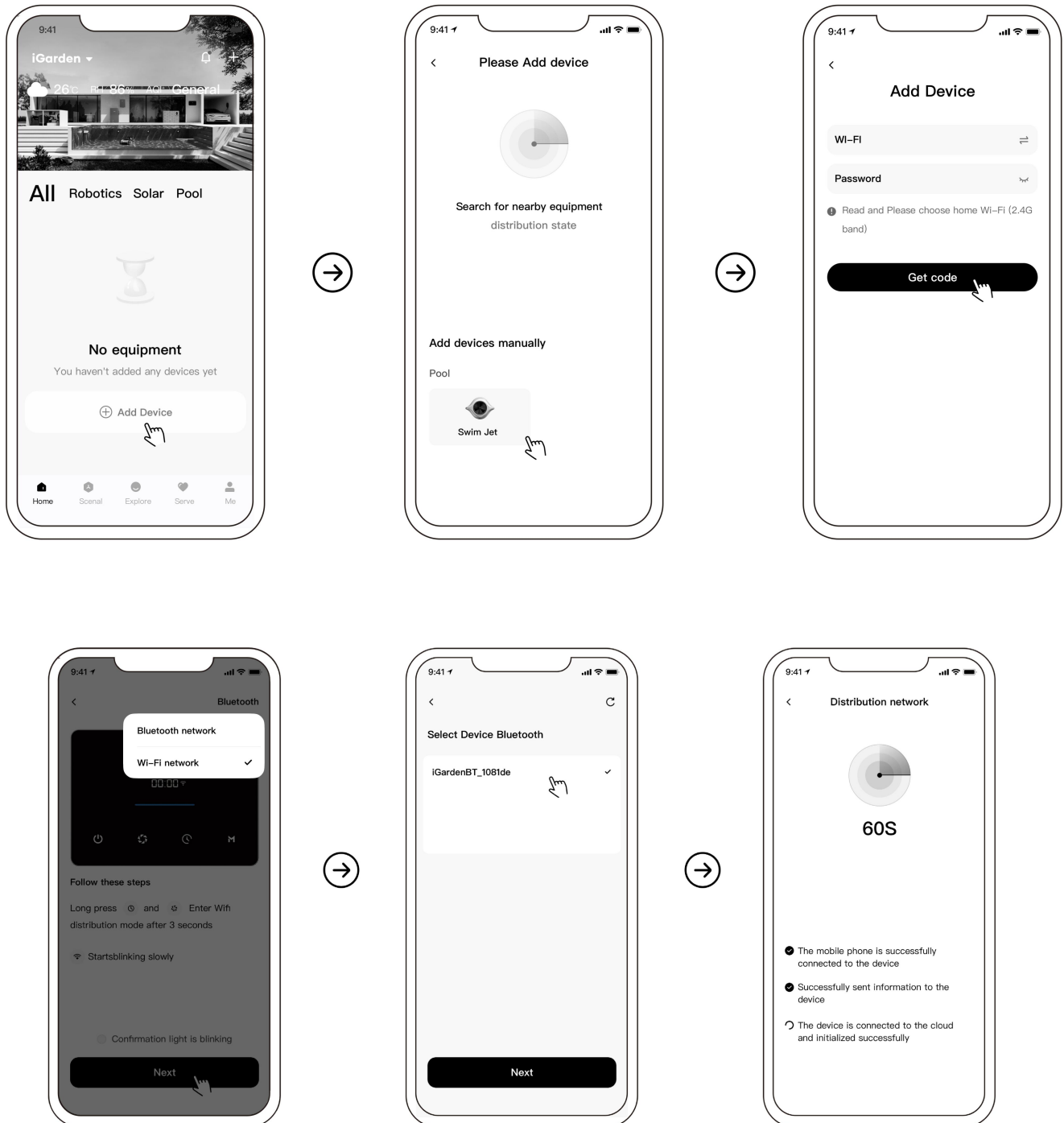

## 8.4 Interface Functions

### 8.4.1 Interface control

After clicking on the device to start, it will enter the free mode by default. The operation page is as follows. Users can switch modes, adjust speed, set time and turn on or off.

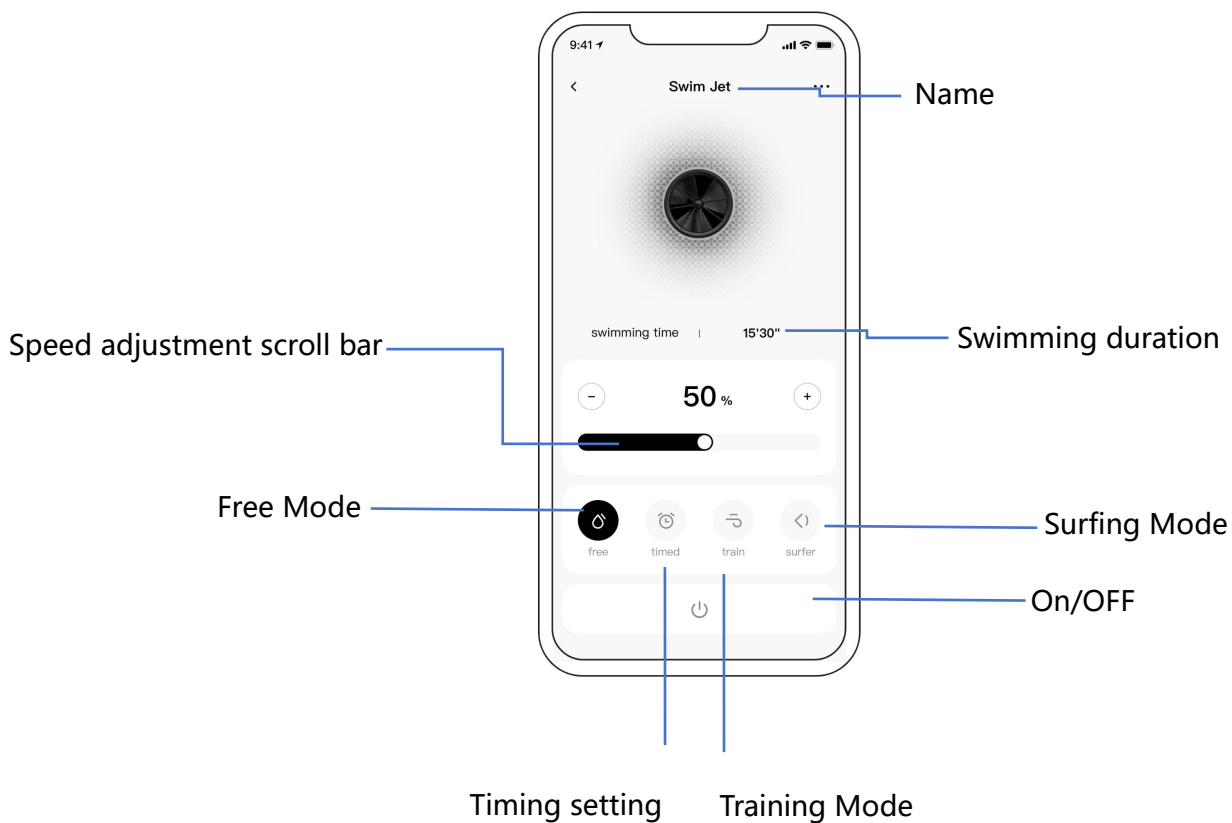

### 8.4.2 Sharing Devices

As a iGarden manager, you can share a device for use by other users via the device details page.

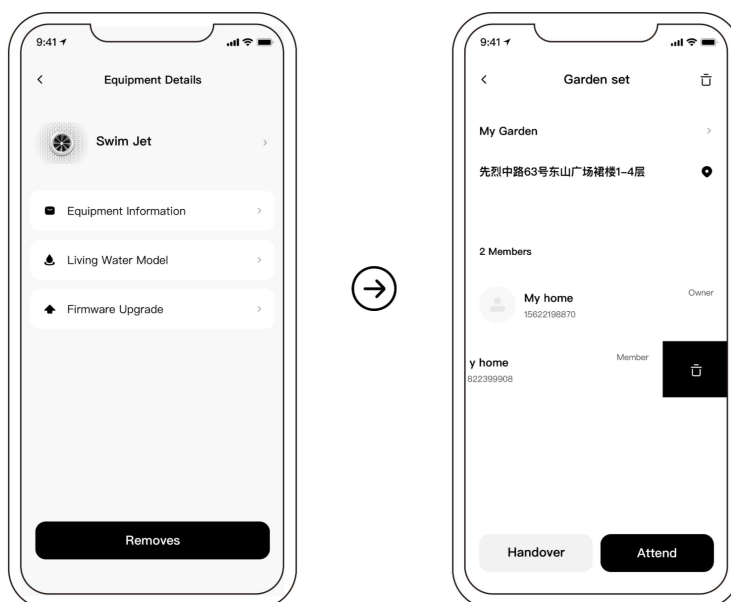

### 8.4.3 Fault Alarm

During the use of the product, if a device fault occurs, the fault name and fault code will be displayed on the device

control page or message center. If the fault cannot be resolved by yourself, please contact the dealer for processing.

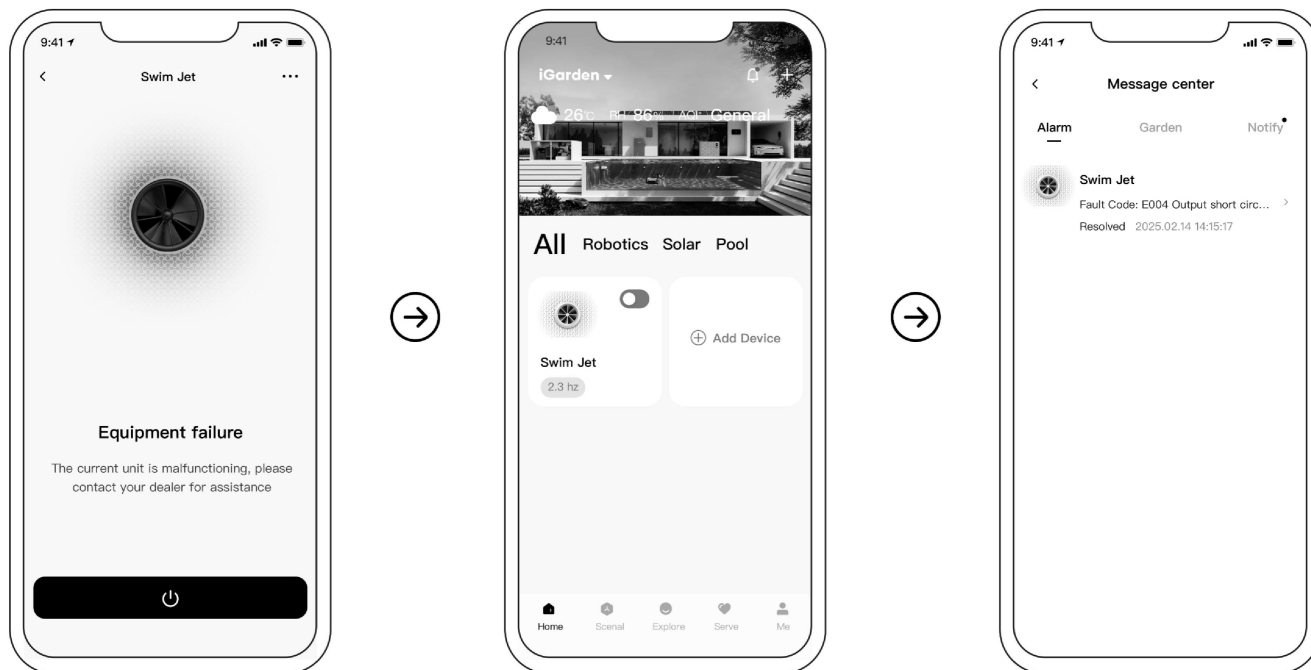

## 9. Product Care and Maintenance

When the product is not used for a long time, disassemble the Jet for indoor storage.

1. Turn off the power;
2. Disconnect the power supply cable;
3. Disconnect the control cable on the bottom of controller;

### Special precautions for winter storage:

In winter, please lower the pool water level to below the Jet to ensure that the Jet is not immersed in water.





**WARNING:** When storing the cable plug of Jet, it needs to be covered with a protective sleeve and not exposed to the air.

## 10. Failure and Protection

### 10.1 Fault detection

- Fault Occurrence: When the Swim Jet detects a fault (except for speed reduction strategies), it will automatically shut down and display a fault code.

- **Auto-Recovery:** After 30 seconds of shutdown, if the fault is resolved, the device will automatically restore to its pre-fault state. If the fault reoccurs, it will shut down again and display the fault code, continuing to wait in 30-second intervals until resolved.

- **Fault Lockout:** If three faults occur within one hour, the system will lock the fault state and disable auto-recovery. In this case, manual power cycling by a technician is required. When multiple faults occur, you can press  and  to switch to view the fault information, if there is no operation, the screen will automatically switch the display every 5 seconds.

- **Note:** The above is the fault detection process except motor stalling. Once the motor is stalled, the Jet will stop immediately. Please cut off the power and reconnect it before resuming to operate.

The fault diagram is as follows, the top right corner of the screen  for the total number of errors, right in the middle  for the current error number, the bottom  for the error code.

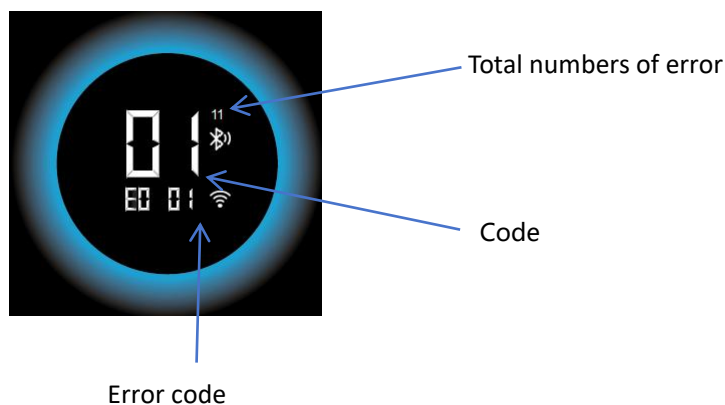

### 10.2 Error codes list:

SN	Error code	Description	Reason
1	E0 01	Abnormal bus voltage	The bus voltage effective value deviates from the normal operating voltage range (too low or too high)
2	E0 02	Output current overcurrent fault	SwimJet current peak is greater than the preset maximum.
3	E0 03	Output current imbalance	The 3 output currents are unbalanced.
4	E0 04	Output shorted	Output wires (wires from the box to the Jet) are short-circuited or high current is present.
5	E0 05	Output Out-of-Phase	Poor contact of output wires or internal wiring problems
6	E0 06	Motor stalling	The motor is tangled or stuck by foreign objects and cannot rotate
7	E0 07	Motor not full of water protection	The motor is not completely immersed in water, and it goes into fault and shuts down after running for 30 seconds.
8	E1 01	MOS overheating	The temperature of the mos tube on the driver board is too high.
9	E1 02	High temperature for controller	The internal temperature of the controller is too high.

10	E2 01	Temperature sensor failure	The temperature sensor on the driver board or the temperature sensor circuit on the display board is damaged.
11	E2 02	Motor drive failure	The driver board is damaged or the motor control is abnormal.
12	E2 03	Driver Board Communication Failure	The driver board fails to communicate with the main control for 30 consecutive seconds.
13	E2 04	Display communication failure	The communication between the display screen and the power box failed for 5 consecutive seconds.

### 10.3 Speed reduction protection

In order to ensure the safe operation of the Jet, the controller is equipped with the following three kinds of downspeed protection mechanisms:

#### 1. MOS tube high temperature speed limit description

- When the temperature of MOS tube exceeds the set value, the system will automatically slow down, at this time, the interface will alternate between the normal working interface and the chassis high temperature warning (interface display A1).

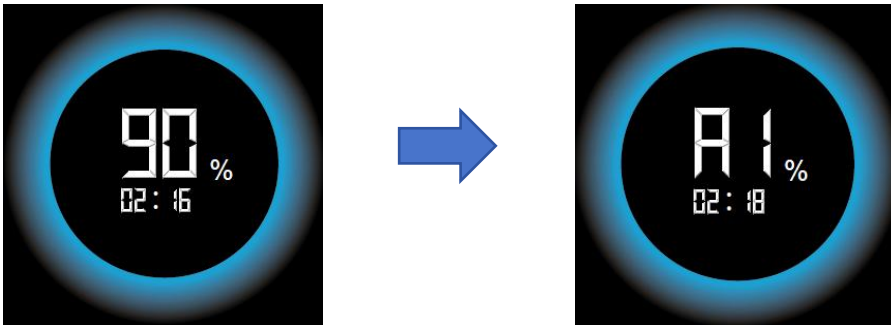

- When the temperature of the MOS tube is too high, the system shuts down and reports an E101 fault.

#### 2. Chassis high temperature protection

- When the chassis temperature exceeds the set value, the system will automatically slow down, at this time the interface will alternate between the normal working interface and the chassis high temperature warning (interface display A2).

- When the chassis temperature is too high, the system will shut down and report E102 fault.

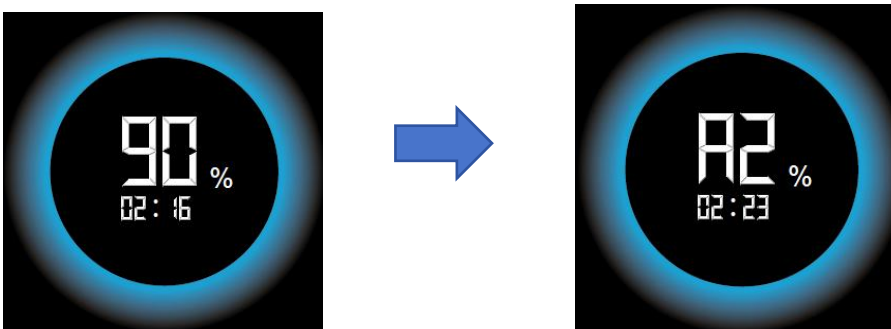

### 3. Output current overload protection

- When the output current exceeds the set value, the system will automatically slow down, at this time the interface will alternate between the normal working interface and the chassis high temperature warning (interface display A3).
- When the output current is too high, the system will shut down and report E002 fault.

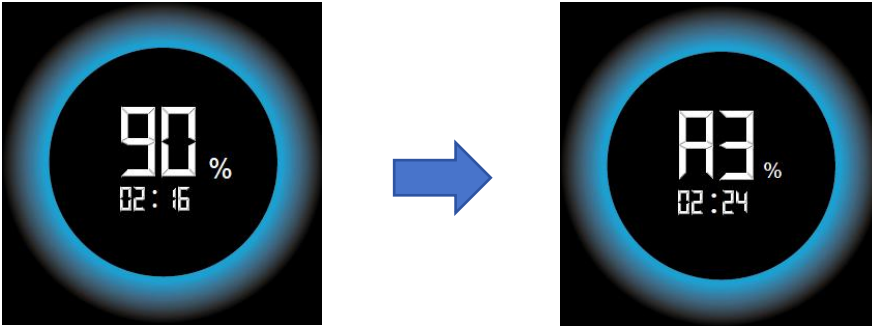

**Note:** In any protection state, the device will automatically adjust the speed to prevent damage and ensure the safe operation of your equipment.

## 11. FAQ & Solutions

Problem	Reason	Solution
Loud noise	<ul style="list-style-type: none"> <li>• The Jet is not fully submerged in water</li> </ul>	<ul style="list-style-type: none"> <li>• Make sure the Jet is fully submerged in water</li> </ul>
Weak flow	<ul style="list-style-type: none"> <li>• The Jet is not parallel to the water surface</li> </ul>	<ul style="list-style-type: none"> <li>• Check that the screw feet are installed correctly</li> </ul>
	<ul style="list-style-type: none"> <li>• Motor doesn' t work</li> </ul>	<ul style="list-style-type: none"> <li>• If the motor does not work properly, please contact your dealer.</li> </ul>
No LCD display	<ul style="list-style-type: none"> <li>• The controller is not connected to the power supply or the switch is off.</li> <li>• Display panel receiving signal failure</li> </ul>	<ul style="list-style-type: none"> <li>• Ensure that the controller is powered on and the switch is open.</li> </ul>

## 12. Disposal

### 12.1 Equipment retirement

- 1.Switch off the power.
- 2.Turn off the power around the pool.
- 3.Disconnect the power cord.
- 4.Disconnect the motor cable under the controller.

## 12.2 Disposal



When disposing of this product, please sort it into electrical or electronic product waste or give it to your local waste recycling system. By recovering and recycling the equipment separately at the point of disposal, you can ensure that it is disposed of in a manner that is beneficial to human health and the environment.

Contact your local authorities to find out where you can recycle your Swim Jet.

## 13. Certification Standards

All Swim Jet models comply with the following specific standards:

LVD Instruction: 2014/35/EU	
■ EN 60335-1	
■ EN 60335-2-41	
■ EN 62233:2008	
EMC Instruction: 2014/30/EU	
■ EN 55014-1	■ EN 55014-2
■ EN 61000-3-2	■ EN 61000-3-3

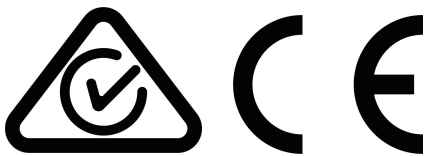

Contact us:

**Aquagem Technology Limited**

Email: [Sales@aquagem.com.cn](mailto:Sales@aquagem.com.cn)

Phone: (0086) 20 3781 4527      Fax: (0086) 20 3781 4527

Add: 5th Floor, C6 Building, Nanlong Industrial Zone, PanYu, GuangZhou, P.R. China