

# SERVICE MANUAL

CDP 40-50-70 & CDP-T 40-50-70

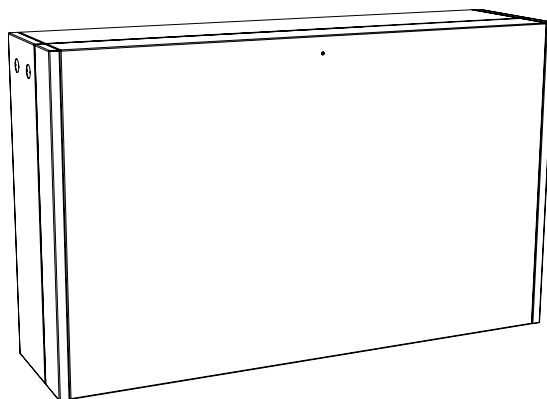

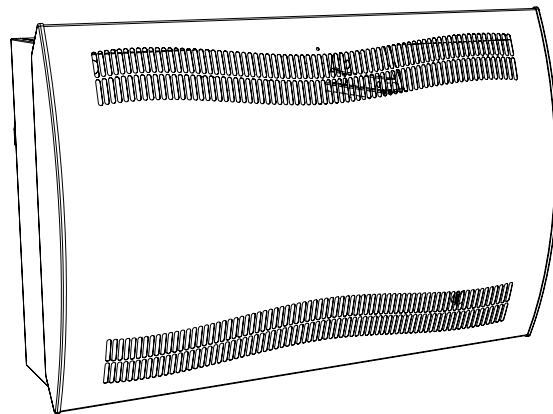

# Introduction

## Table of contents

---

<b>Introduction</b> .....	<b>3</b>
Table of contents .....	3
Overview .....	4
Declaration of Conformity .....	5
<b>Product description</b> .....	<b>6</b>
Overall description .....	6
Enclosure dimensions .....	10
Technical data .....	11
<b>Installation</b> .....	<b>12</b>
Installation environment .....	12
Wall mounting .....	13
Electrical connection .....	18
<b>Operation</b> .....	<b>21</b>
Control panel .....	21
<b>Maintenance and care</b> .....	<b>24</b>
Preventative maintenance .....	24
Software update and log files .....	25
Trouble shooting .....	27
Spare parts .....	34
<b>Schematics</b> .....	<b>35</b>
Cooling circuit .....	35
Main PCB .....	36
Wiring diagram .....	37

---

## Overview

---

**Target group** The target group for this service manual is the technicians who install and maintain the CDP 40-50-70 and CDP 40T-50T-70T dehumidifier. Thus the manual covers instructions about installation, operation and maintenance.

---

**Safety precautions** It is the responsibility of the operator to read and understand this service manual and other information provided and to use the correct operating procedure.  
Read the entire manual before the initial start-up of the unit. It is important to know the correct operating procedures for the unit and all safety precautions to prevent the possibility of property damage and/or personal injury.

It is the responsibility of the installer to ensure the conformity of all, not supplied cables towards national regulations.

---

**Copyright** Copying of this service manual, or part of it, is forbidden without prior written permission from Dantherm.

---

**Reservations** Dantherm reserves the right to make changes and improvements to the product and the service manual at any time without prior notice or obligation.

---

**Recycling** The unit is designed to last for many years. When the time comes for the unit to be recycled, it should be recycled according to national rules and procedures to protect the environment. The CDP dehumidifiers contain R407C refrigerant and compressor oil. The compressor must be returned to authorities for disposal according to local regulations.

---



**DANGER**

**Type and source of hazard**

This symbol in connection with the word "Danger" warns of a high risk or severe injury or acute danger to life.

- Measures to avert danger or immediate measures if the risk occurs are described in this way
- 



**WARNING**

**Type and source of hazard**

This symbol in connection with the word "Warning" warns of a risk involving severe injury.

- Measures to avert danger or immediate measures if the risk occurs are described in this way
- 



**CAUTION**

**Type and source of hazard**

This symbol in connection with the word "Caution" warns of a risk of minor or moderate injury and material damage.

- Measures to avert danger or immediate measures if the risk occurs are described in this way
- 



**NOTICE**

In connection with this symbol you will find further tips and information concerning the use of the device.

---

## Declaration of Conformity

---



**Declaration**

Dantherm hereby, declare that the unit mentioned below:

No.: 351510, 351516, 351511, 351517, 351512 & 351518  
Type: CDP 40, CDP 40T, CDP 50, CDP 50T, CDP 70 & CDP 70T

- complies with the following directives:  
2006/42/EC Machinery Directive  
2014/30/EU EMC Directive  
2011/65/EU RoHS Directive  
1907/2006/EC REACH Regulation

- and is manufactured in compliance with the following harmonized standards:  
DS/EN ISO 12100-2010 Safety of machinery - General principles for design  
EN 60 335-1:2012 Household and similar electrical appliances - Safety - Part 1  
EN 60 335-2-40:2003 Household and similar electrical appliances - Safety - Part 2-40  
EN 60335-2-40: A1 2006 Household and similar electrical appliances - Safety - Part 2-40  
EN 378-1:2016 Refrigerating systems and heat pumps  
- Safety and environmental requirements - Part 1  
EN 378-2:2016 Refrigerating systems and heat pumps  
- Safety and environmental requirements - Part 1

Skive, 18.03.2021

  
Mikkel Haldrup Jensen  
Project manager designer

  
Jakob Bonde Jessen  
Managing director

## Product description

### Overall description

**Air flow direction** This illustrates the functional principle of the CDP 40-50-70.

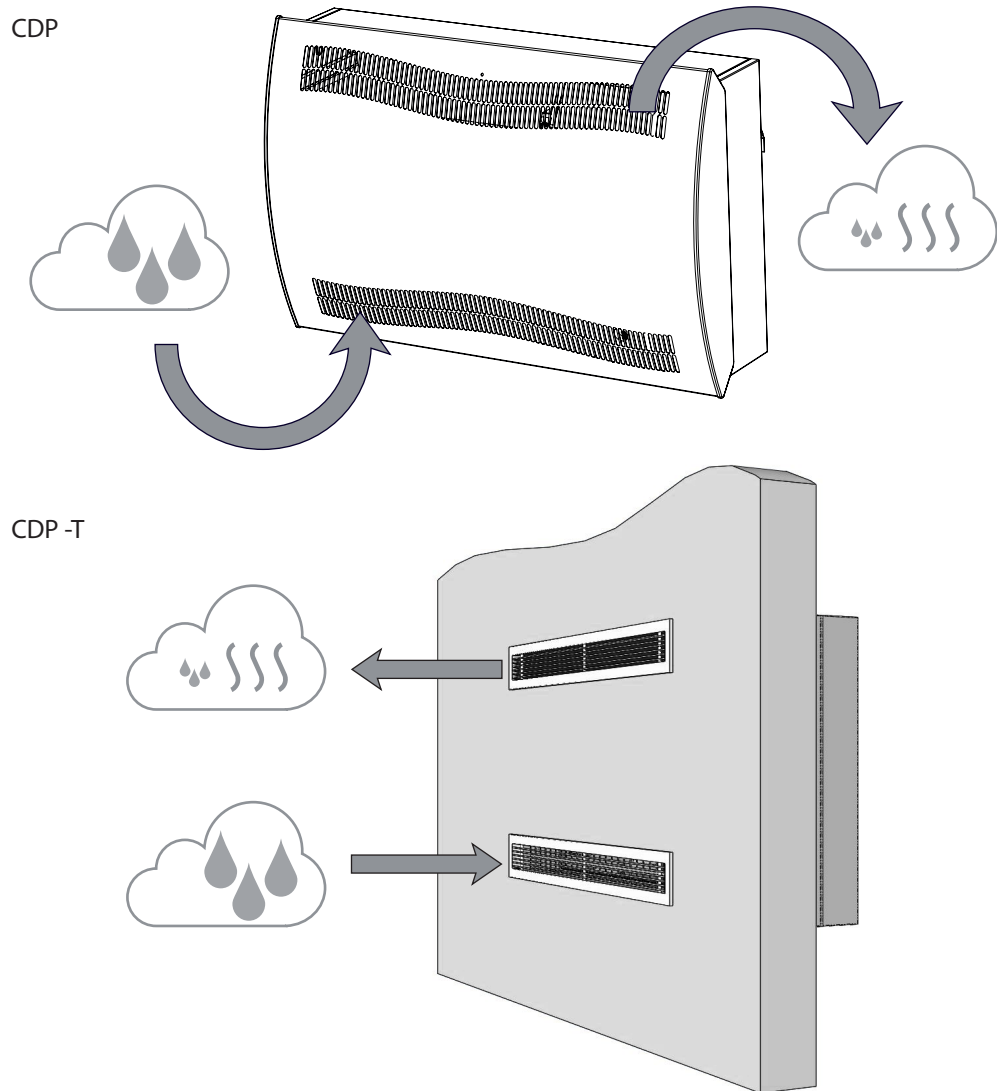

Fig. 1

### Functionality of the dehumidifier

CDP 40-50-70 and CDP 40T-50T-70T work in accordance with the condensation principle. Humid air from the pool room is drawn into the unit by one or two fans. When passing through the evaporator the air is cooled down to below dew point and water vapour is condensed into water, which is drained. The dry air is then passed through the condenser where it is heated and returned to the pool room. As a result of the latent heat from the condensation process and the compressor energy the return air temperature to the pool room is approx. 5°C higher than the air from the pool room.

**Fan control**

When the dehumidifier is started by the hygrostat, the fan(s) are activated at the same time as the compressor.

In order to check the humidity level the units are starting the fan(s) once an hour for one minute (**NOTE: only applicable to CDP 40T-50T-70T units**):

- If the humidity is above the selected setpoint, the unit starts dehumidifying.
- If the humidity is below the setpoint, the unit will remain off and check the humidity level again after one hour.

**Compressor control**

To protect the compressor against overloading there is a timer which prevents the dehumidifier from starting more than 10 times pr hour. It means, that there is at least 6 minutes between every start up.

**Defrosting**

This unit is equipped with an intelligent defrosting strategy.

The unit monitors the temperature of the evaporator, and when the temperature has been below a certain temperature for a period of time, the dehumidifier will switch to active defrosting, the fans will stop, and the magnetic valve will open.

The hot gas can now pass through the evaporator.

When the evaporator has the right temperature again the magnet valve will close and the dehumidification will continue.

**Safety circuit**

If the temperature in the dehumidifier increases to a temperature of more than 55 °C (in case of fan failure or room air temperature higher than 36 °C), the compressor stops automatically to avoid damaging it. When the temperature allows it the dehumidification will continue.

**Cable groove (accessory)**

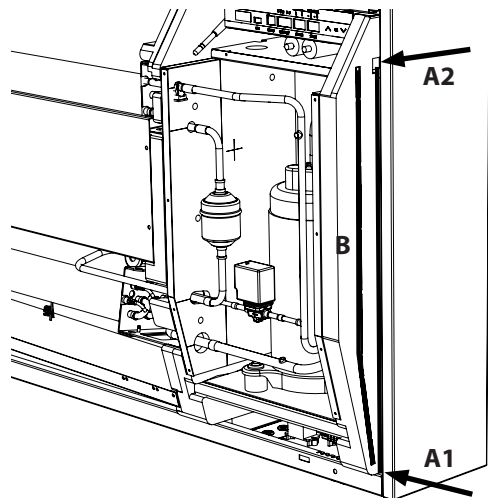

Two cable grooves for accessory make it easy to guide the cables from the control panel to the mains electricity connection and out of the unit.

Groove B is for use with cable from external RH sensor as it requires a separate groove to avoid interference.

All other accessory cables are to be placed in groove A1-A2.

**LED**

An LED is placed at the front of the unit. The LED light indicates different modes of the unit.

Find a description of the different modes in section "LED light and troubleshooting" on page 28.



**CDP  
Presentation**

Pos.	Part	Illustration
1	LED lamp	<p>The illustration consists of four technical drawings of a rectangular Dantherm CDP unit.   <b>Front cover:</b> Shows the front face with two horizontal grilles. Callout 1 points to the top grille, callout 2 to the top edge, and callout 3 to the bottom grille.   <b>Inside (front cover removed):</b> Shows the interior with a control panel (5) on the right, a cable groove (6) below it, and a humidity sensor (7) at the bottom right. Callout 4 points to the bottom edge.   <b>Rear view:</b> Shows the back of the unit with wall mounting spacers (8) and a wall bracket (10) on the right side.   <b>Bottom view:</b> Shows the base of the unit with a water drain (11) on the left and a mains electricity connection (9) on the right.</p>
2	Air outlet	
3	Air inlet	
4	Drip tray	
5	Control panel (behind the cover)	
6	Cable groove (for accessory only)	
7	Humidity sensor	
8	Wall mounting spacers (incl. in delivery)	
9	Mains electricity connection (behind the lid)	
10	Wall bracket	
11	Water drain	

Fig. 2



**CDP-T  
Presentation**

Pos.	Part	Illustration
1	LED lamp	<p>The illustration consists of four technical drawings of the CDP-T device. 1. 'Front cover' view showing a rectangular panel with a callout '1' pointing to the top edge. 2. 'Inside (front cover removed)' view showing the internal components: a control panel (2) at the bottom, a drip tray (3) at the top, and a cable groove (4) on the right side. 3. 'Rear view' showing the back of the device with a wall bracket (5) on the left, an air outlet (7) at the top, a humidity sensor (8) in the middle, and an air inlet (9) at the bottom. 4. 'Bottom view' showing the underside with a water drain (10) on the left and a mains electricity connection (6) on the right.</p>
2	Control panel (behind a cover)	
3	Drip tray	
4	Cable groove (for accessory only)	
5	Wall bracket	
6	Mains electricity connection (behind the lid)	
7	Air outlet	
8	Humidity sensor	
9	Air inlet	
10	Water drain	

Fig. 3

**Enclosure dimensions**

**CDP 40-50-70**

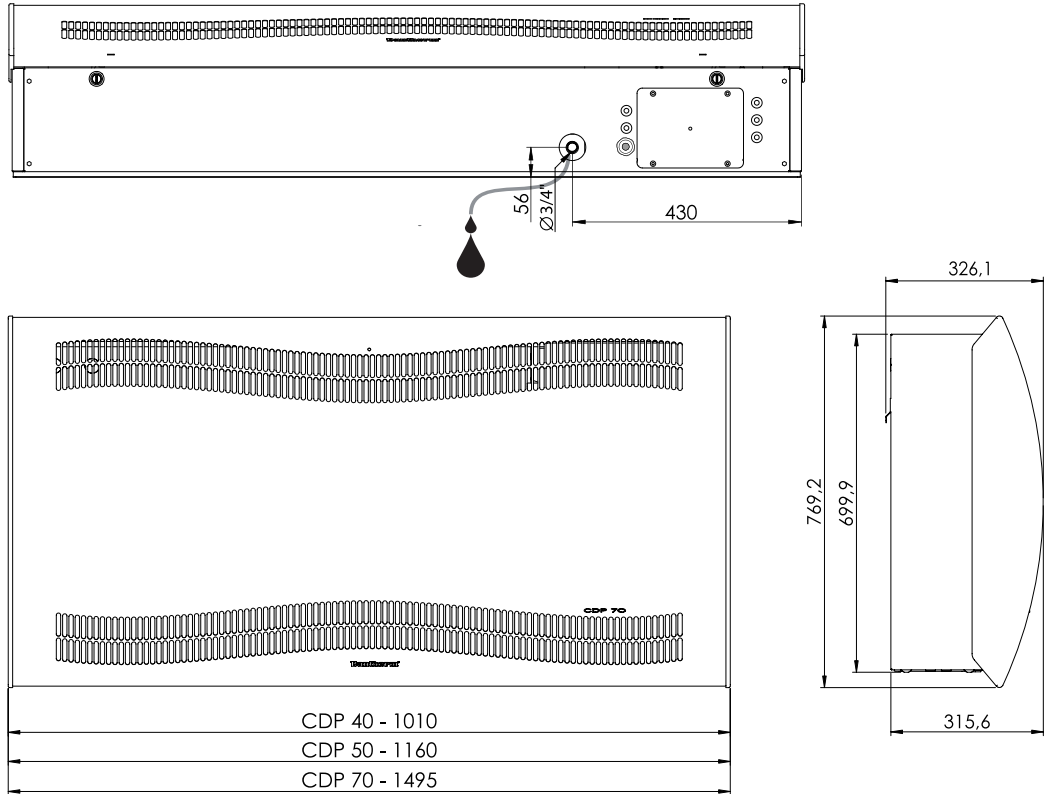

Fig. 4

**CDP 40T-50T-70T**

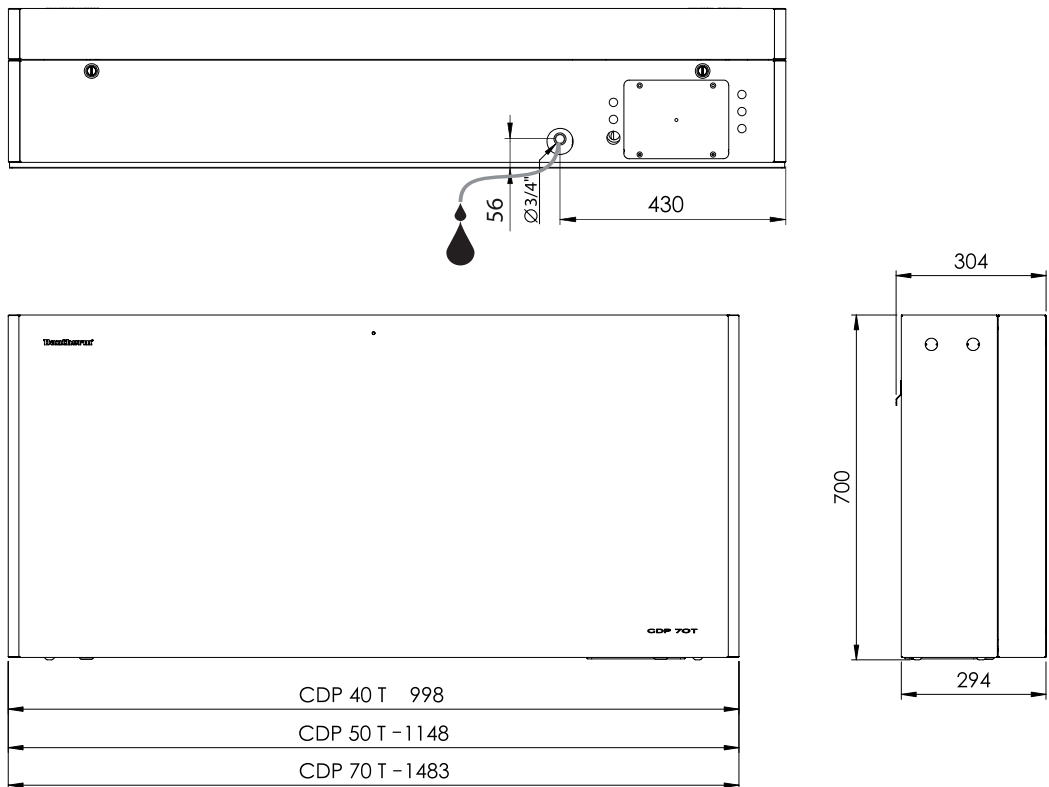

Fig. 5



## Technical data

### Data sheet

Specification	unit	CDP 40	CDP 40T	CDP 50	CDP 50T	CDP 70	CDP 70T
Operating range, humidity	%RH	40-100	40-100	40-100	40-100	40-100	40-100
Operating range, temperature	°C	10-36	10-36	10-36	10-36	10-36	10-36
Air volume at max. external pressure	m <sup>3</sup> /h	400	400	680	680	900	900
Capacity at 28°C - RH 60	l/day	34	34	52	52	69	69
SEC 28°C - RH 60	kWh/l	0,47	0,47	0,48	0,48	0,43	0,43
Power supply	V/Hz	1×230/50	1×230/50	1×230/50	1×230/50	1×230/50	1×230/50
Max. power consumption	kW	0.9	0.9	1.5	1.5	1.8	1.8
Max Ampere consumption	A	3,8	3,8	6,6	6,6	8	8
Refrigerant	-	R407C					
Quantity of refrigerant	kg	0.7	0.7	0.9	0.9	1.2	1.2
GWP (Global Warming Potential)	-	1774					
Noise level* (1 m from unit)	dB(A)	46	43	47	44	50	47
Weight	kg	56,5	57,5	65,0	66	75,5	77,5
Filter Type		PPI 15					
Protection class		IPX4					

## Installation

### Installation environment

#### Water quality in indoor pools

The correct combination of chemicals in an indoor swimming pool is crucial, both for the health of users and for the inventory inside the pool room and the swimming pool's technical room. Insufficiently treated water results in poor hygiene, while water that has been excessively treated results in gases in the air that contain chlorine, which can irritate the eyes and cause breathing difficulties.

At the same time, the incorrect composition of chemical ingredients in the water can destroy all of the inventory in a very short space of time, including the dehumidifier and other equipment that have been installed to process the air.

Shown below are the threshold values, which apply to products for indoor swimming pools in accordance with EN/ISO 12944-2, protection class C4. These threshold values must be complied with for the warranty to be valid.

#### When adding chemicals

The following guideline values are applicable to swimming pools with the addition of chemicals.

Chemicals	ppm
Free chlorine content	1.0-2.0
Combined chlorine content	Max. 1/3 of free chlorine content
pH	7.2-7.6
Total alkalinity	80-150
Calcium hardness	250-450
Total dissolved solids	< 2000
Sulphates	< 360

#### With own production of chlorine

The following guideline values are applicable to swimming pools with self-production of chlorine:

Chemicals	ppm
Salt (NaCl)	< 30,000
Total dissolved solids	< 5500
pH	7.2-7.6
Total alkalinity	80-150
Calcium hardness	250-450
Sulphates	< 360

#### Langelier Saturation index

It is advisable to use the Langelier Saturation index to ensure that the combination of the different water parameters is acceptable. Contact Dantherm A/S if necessary.

#### Optimal conditions



**NOTICE**

- The CDP 40T-50T-70T units are designed for installation in a heated room, adjacent to the pool room.
- Do not place the dehumidifier close to a heating source, e.g. a radiator.
- Doors and windows must be kept closed when the dehumidifier is in function.
- To make sure that the room air passes freely through the dehumidifier, air inlet and air outlet openings must be free.

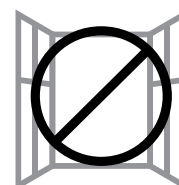
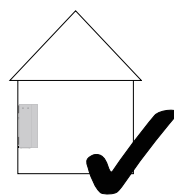
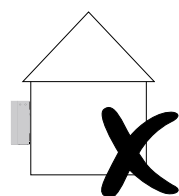



## Wall mounting

### Mounting CDP 40-50-70

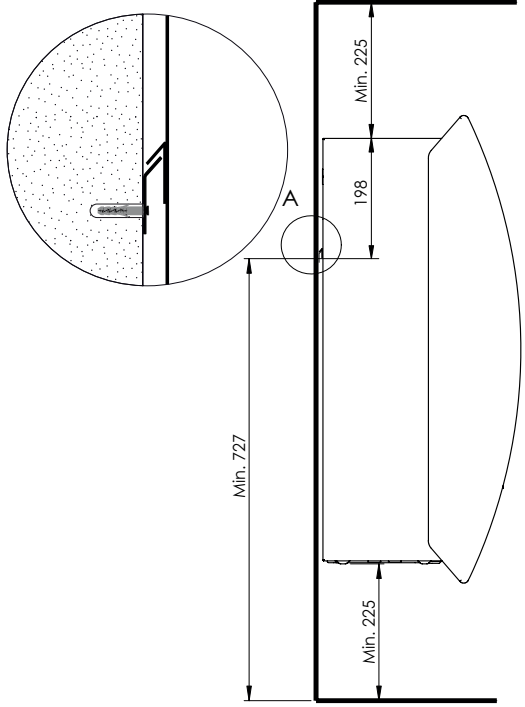
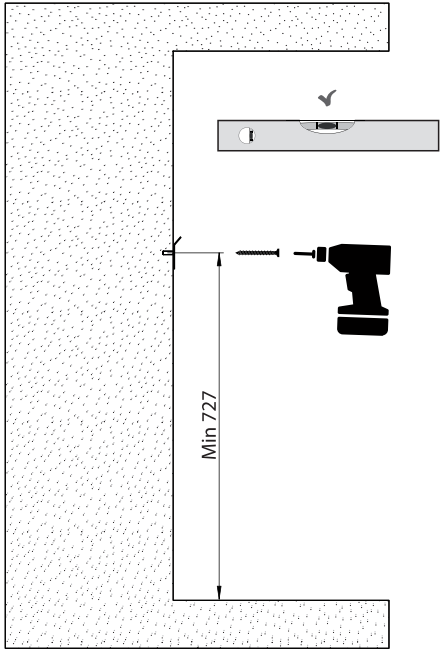
Please follow this procedure to mount the CDP 40-50-70:  
(Go to page 15 for instructions on wall mounting of the CDP-T range)

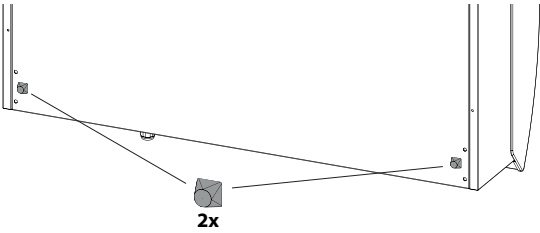

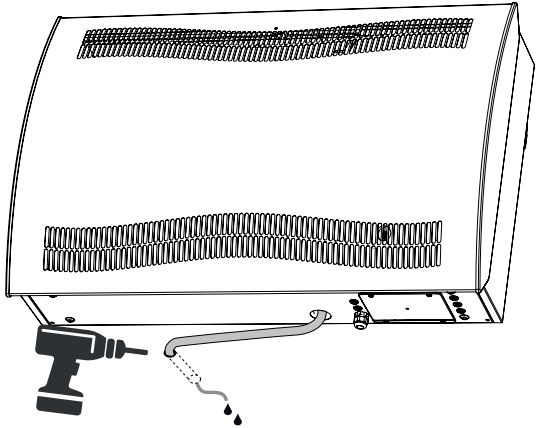
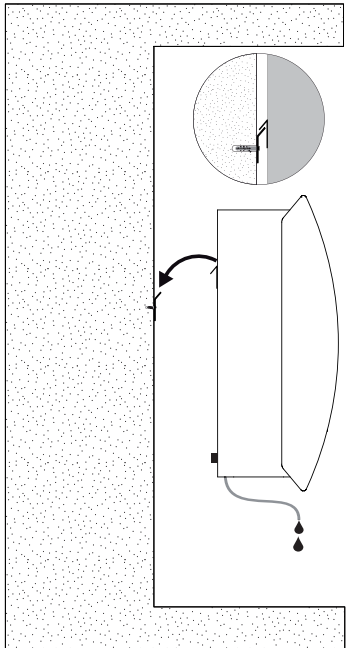
Step	Description	Illustration
1	<p>Find the right spot for the CDP dehumidifier and measure where the wall suspension bar has to be mounted.</p> <p>Recommended distance from dehumidifier to:</p> <ul style="list-style-type: none"> <li>• Ceiling: min 225 mm</li> <li>• Floor: min 225 mm</li> </ul>	
2	<p>Fix the wall suspension bar supplied with the unit to the wall.</p> <p><b>NB:</b> It is important to fix it horizontally to ensure correct condensate outlet.</p>	

<p>3</p>	<p>Fasten the two wall mounting spacers (included in the delivery) on the back of the unit.</p>	
<p>4</p>	<p><b>Drain outlet:</b> Connect a drain hose and make a condensate outlet through the wall.</p> <p> Connect a 3/4" flexible or fixed water hose to the spigot at the base of the dehumidifier. Make sure the drainage has a drop of at least 2 %.</p> <p><b>Alternatively:</b></p> <ul style="list-style-type: none"> <li>• A condensate pump can be fitted at the water outlet in order to pump the water to a drain.</li> </ul>	
<p>5</p>	<p>Hang the dehumidifier on the wall suspension bar.</p>	

**Mounting**  
**CDP 40T-50T-70T**

Please follow this procedure to mount the CDP 40T-50T-70T:  
(Go to page 13 for instructions on wall mounting of the CDP 40-50-70 units)

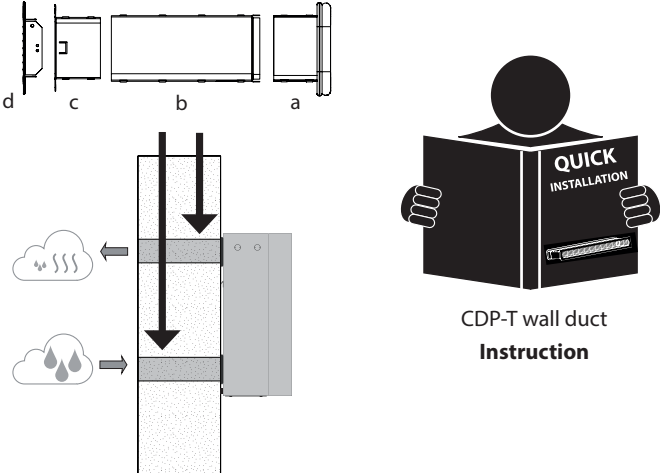
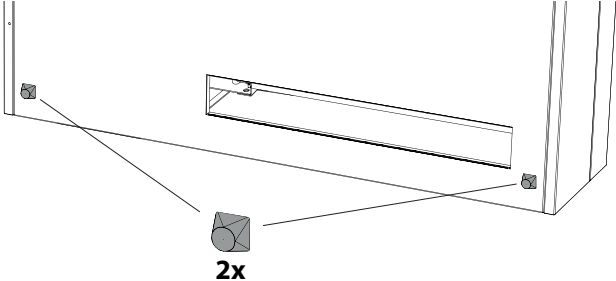
Step	Description	Illustration								
1	<p>Find the right spot for the CDP-T dehumidifier and measure where the wall suspension bar has to be mounted.</p> <p>Fix then the wall suspension bar supplied with the unit to the wall.</p> <p><b>NB:</b> It is important to fix it horizontally to ensure correct condensate outlet.</p>	<table border="1"> <thead> <tr> <th></th> <th>CDP 40T</th> <th>CDP 50T</th> <th>CDP 70T</th> </tr> </thead> <tbody> <tr> <td><b>Y</b></td> <td>437</td> <td>341</td> <td>450</td> </tr> </tbody> </table>		CDP 40T	CDP 50T	CDP 70T	<b>Y</b>	437	341	450
	CDP 40T	CDP 50T	CDP 70T							
<b>Y</b>	437	341	450							
2	<p>Make a hole in the wall according to the measurements of the illustration.</p>	<table border="1"> <thead> <tr> <th></th> <th>CDP 40T</th> <th>CDP 50T</th> <th>CDP 70T</th> </tr> </thead> <tbody> <tr> <td><b>Z</b></td> <td>610</td> <td>760</td> <td>1095</td> </tr> </tbody> </table>		CDP 40T	CDP 50T	CDP 70T	<b>Z</b>	610	760	1095
	CDP 40T	CDP 50T	CDP 70T							
<b>Z</b>	610	760	1095							

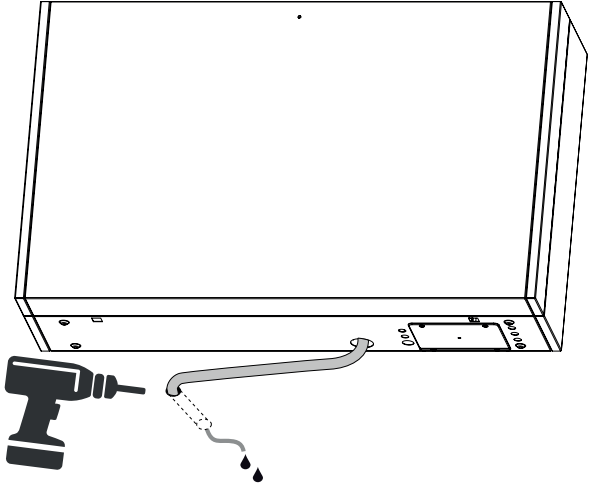
<p>3</p>	<p>Use CDP-T wall duct in order to seal between unit and wall.</p> <p>See how to mount the wall duct correctly in the CDP-T wall duct instruction.</p>	
<p>4</p>	<p>Fasten the two wall mounting spacers (included in the delivery) on the back of the unit.</p>	
<p>5</p>	<p><b>Drain outlet:</b> Connect a drain hose and make a condensate outlet through the wall.</p> <p> Connect a 3/4" flexible or fixed water hose to the spigot at the bottom of the dehumidifier. Make sure the drainage has a drop of at least 2 %.</p>	
<p><b>Alternatively:</b></p> <ul style="list-style-type: none"> <li>• A condensate pump can be fitted at the water outlet in order to pump the water to a drain.</li> </ul>		



6 Hang the dehumidifier on the wall suspension bar.

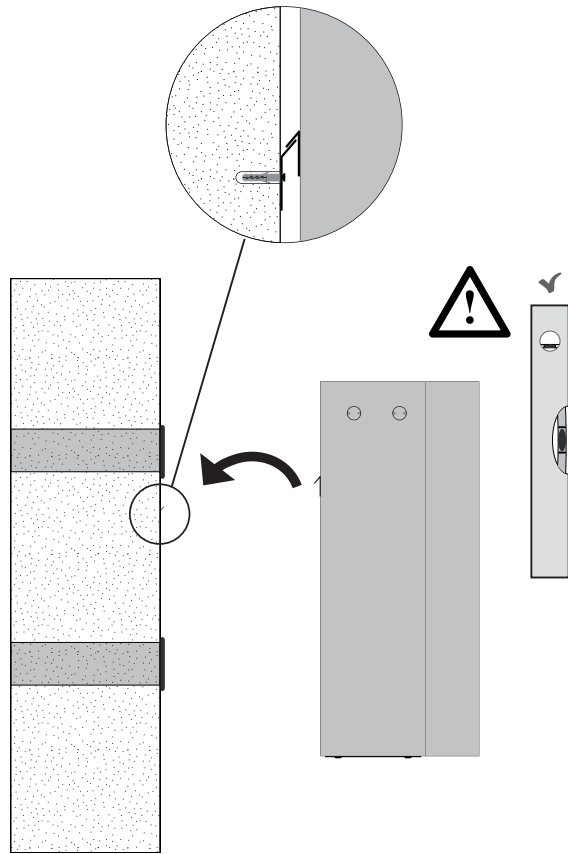

## Electrical connection



**CAUTION**

### Risk of damaging the dehumidifier, if it has been lying down.

The compressor can be damaged permanently, when the unit is started up just after it has been lying down.

- Wait 1 hour with the start up of the dehumidifier, if the unit has been lying down (e.g. during transport or installation).



**DANGER**

### Risk of electric shock

An electric shock can cause severe burning and in most extreme cases shock to the brain, strain to the heart, injury to other organs or result in death.

- Switch off the power on the main switch, while you open the dehumidifier.
- Remember also to switch off the power, while you close the dehumidifier.

### Connection of power supply

Step	Description	Illustration
1	Loosen the two screws that secure the lid to the mains electricity connection. Tilt the lid in order to get access to the terminals.	
2	Guide the cable for the power supply through the PG cable restrainer.	
3	Connect the power to the unit in accordance with the description stated on the name plate.  See also "Wiring diagram" on page 35.	
4	Close the lid and fix it with screws again.	

**NOTICE**

It is the responsibility of the installer to ensure the conformity towards national regulations of all, not supplied cables.

**Control panel interfaces**

The interfaces and terminals on the control panel make it possible to communicate with the dehumidifier and connect accessory such as a RH/T sensor, an alarm and a heating coil. The figure and table below describe the different functions of the interface.

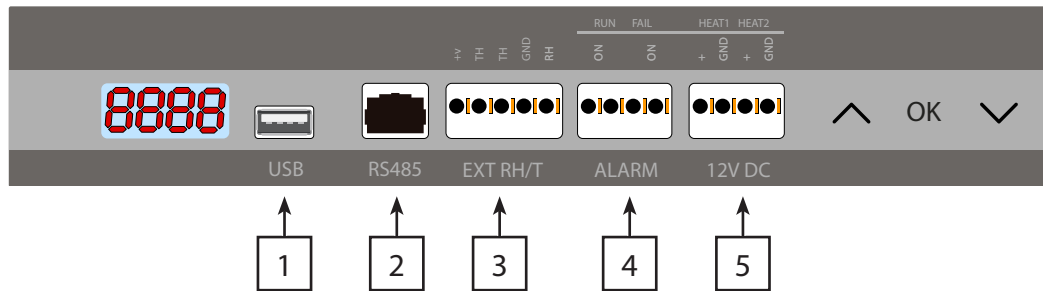

Fig. 6

Pos.	Interface	Description
1	USB	USB is used for datalogging/ software update. See more information in section "Software update and log files" on page 25.
2	Modbus RTU (RS-485)	Connection via modbus. A list of data for the Modbus interface can be downloaded on support.dantherm.com
3	External RH/T sensor	Terminals for connecting an external humidity/ temperature sensor. See wiring example in Fig. 7
4	Alarm	An external alarm can reveal, if the dehumidifier is operating normally or has an error. See wiring example in Fig. 8
5	12 VDC Heat control	Connection of LPHW (water) or electric heating helps controlling the indoor temperature. Contact your Dantherm dealer for more information.

**External RH/T sensor connection (Optional)**

There is an option for connecting an external RH/T sensor, which makes it possible to overrule the internal sensors. In Fig. 7 there is an example on how it could be connected.

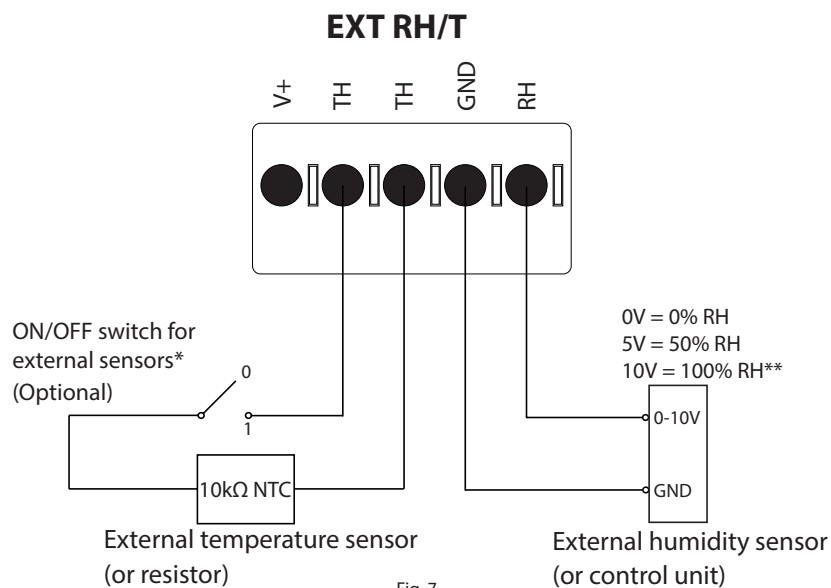

Fig. 7

\*Switch in position: 0 = Internal sensors in use, 1 = External sensors in use

\*\*Note, operational range is within 40-99% RH, if out of range the dehumidifier will be in stand by mode

**Alarm  
Run/ fail  
connection  
(Optional)**

There is an option for connecting an external alarm, which makes it possible to see, when the dehumidifier is operating normally or has an error. In order to use this option you must create your own external electrical circuit and connect it to the run/fail terminal on the main PCB (see page 34).

This illustration is an example of how the run/fail circuit could be used.

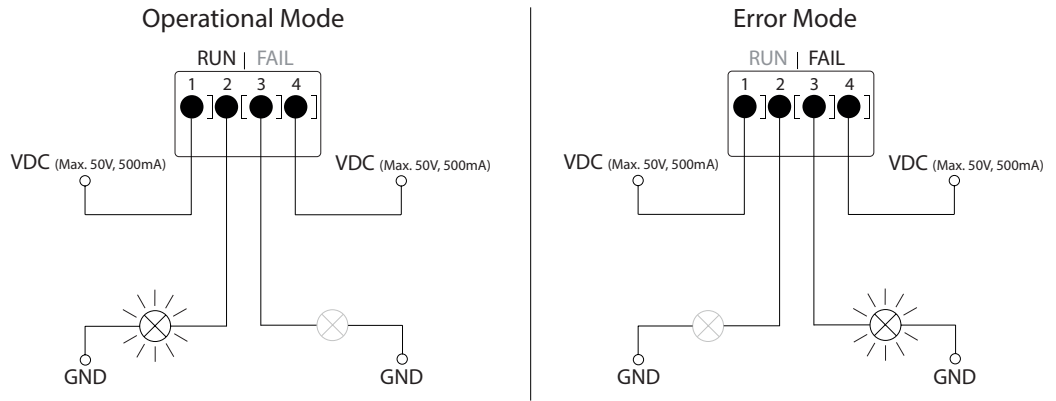

Fig. 8

## Operation

### Control panel



**DANGER**

#### Risk of electric shock

An electric shock can cause severe burning and in most extreme cases shock to the brain, strain to the heart, injury to other organs or result in death.

- Switch off the power on the main switch, while you open the dehumidifier.
- Remember also to switch off the power, while you close the dehumidifier.

#### Accessing the control panel

Follow the steps below in order to access the control panel.

Step	Description	Illustration
1	<p>Open the dehumidifier:</p> <p>a) Loosen the two screws at the bottom of the unit. Check that the locks release the front cover.</p> <p>b) Pull upwards and remove the front cover.</p>	
2	<p>Loosen the two screws and remove the upper plate (covering the control panel).</p>	

#### Display

4 digit Display divided into 2 sections: The first 2 digits show the code and the last 2 show the value of the code.



#### Default view

By default the display will show the relative humidity RH %. This reading can be from the external humidity/temperature sensor when available, if not the RH will be from the internal humidity sensor.

*Example*



Menu overview

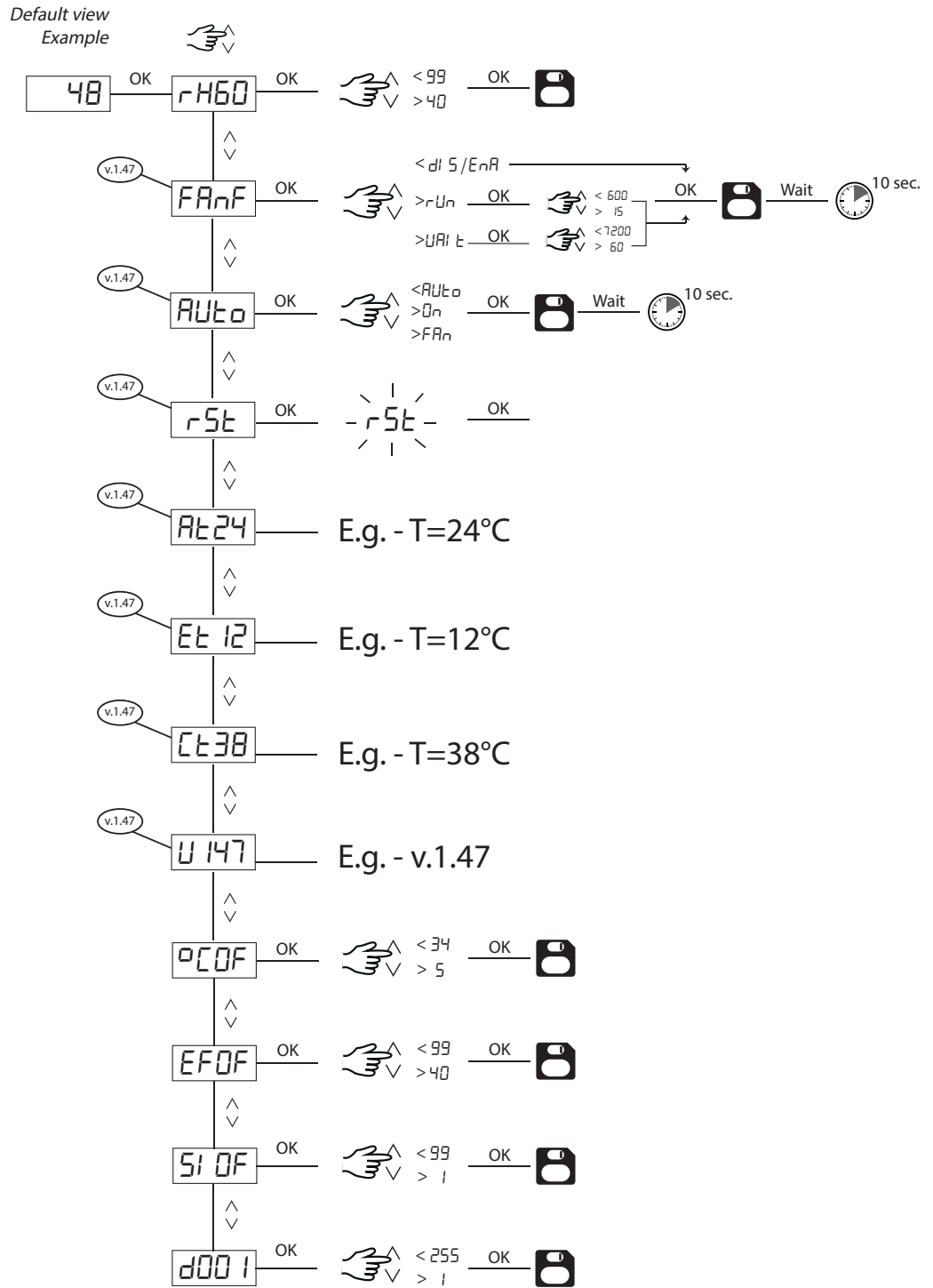

Update to latest software version, if the menu looks different.

**Menu description**

Code	Function	Default value	Value range	Description	
rH	Relative humidity (%)	60	40-99	The unit will start dehumidifying, when the sensor measures a relative humidity higher than the set value. (Note the +/- 2% hysteresis)	
FanF	Fan function				
	diS	Disable / enable	diS (disable)*	Dis/enA Sub menu. Enable or disable fan function. Fan will run periodically when idle to sample air. *in CDP-T the function is enabled as default	
	Run	Run time	60	15-600	Sub menu. Fan run time in seconds.
	wait	Wait time	3600	60-7200	Sub menu. Fan wait time in seconds.
AUTO	Mode selection	AUTO			
			AUTO	Sub menu. Fan + compressor automatic operation based on Rh set point	
			On	Sub menu. Fan + compressor always active when power is connected (Manual mode)	
			Fan	Sub menu. Fan always active. Compressor automatic operation based on RH set point.	
rSt	Reset	-	rSt	Soft reset unit. Corresponds to switching power supply Off and On. When 'rSt' blinks in display press OK button to reset	
At##	temperature	-	-	Ambient temperature reading from RH-probe. Not adjustable	
Et##	temperature	-	-	Evaporator temperature sensor current value. Not adjustable	
Ct##	temperature	-	-	Condenser temperature sensor current value. Not adjustable	
U147	SW version	-	-	Current application software version. Not adjustable	
°C	°Celsius (accessory only)	OF (OFF)	5-34	The el/water heating coil (accessory) will start to heat, when the temperature is lower than the set value. (Note the +/- 2 °C hysteresis)	
EF	Extractor fan (accessory only)	OF (OFF)	40-99	The extractor fan (accessory) will start, when the humidity is higher than the set value, completely independent of the dehumidifier. The value is measured in % relative humidity. (Note the +/- 2% hysteresis)	
SI	Service Interval (weeks)	OF (OFF)	1-99	When the Service Interval function is enabled, the unit will display SEr, when it is time for service.	
d001	Modbus Slave ID	001	1-255	Connection via modbus is possible. The default modbus slave ID of the unit is 1 and can be changed to a value between 1-255.	

**Menu buttons**



Press and hold OK button for 3 sec to enter menu mode



Toggle Menu Page / change value

Note: If no button is pressed for 10 seconds it will return to Standard view.

## Maintenance and care

### Preventative maintenance

#### Introduction

The dehumidifier requires very little attention for trouble free running. All the necessary safety and control functions have been built in. The fan motor(s) and the compressor have permanent lubrication and require no particular maintenance.



CAUTION

#### **Injury - risk of cuts and minor skin burns, when you access the inside of the CDP**

Be cautious of sharp edges when opening the unit. Internal parts can be very hot or cold.

- Switch off CDP for half an hour prior to opening it. Avoid touching very hot and cold parts as e.g. the pipes or evaporator.
- Avoid touching sharp edges or wear gloves.

#### Monthly service

The air inlet filter is to be cleaned once a month. The filter is placed in a stand behind the grill of the air inlet duct. Drip tray and outlet should also be cleaned, so water can run off freely. Please follow this procedure to perform the monthly service:

Step	Action
1	Unlock the two locks underneath the dehumidifier
2	Dismount the front cap by lifting it up and take out the filter. The filter is located on the rear of the front cap
3	Wash the filter in tepid soapy water or vacuum clean thoroughly. If the filter is faulty, replace it.
4	Insert filter in the filter holder, reattach the cap and lock the two locks. (From Step 1)

**NB:** If the filter (one size PPI filter with order no. 094686) has to be replaced, you can order it through a Dantherm dealer.

#### Annual service

The dehumidifier should be inspected once a year.

Please follow this procedure to perform the annual service:

Step	Action
1	Remove the front from the dehumidifier
2	Inspect the inside of the dehumidifier
3	Vacuum clean the dehumidifier to remove any dust or debris Important: Vacuum clean the condenser thoroughly
4	If necessary wash the lamella evaporator in tepid soapy water if it is badly soiled





## Software update and log files

### Access data log/ USB

If you wish to read the log file from the unit without updating the software follow these steps.

Step	Action
1	Insert an empty FAT32 USB memory stick. Supports total drive volume of max 16Gb only (see section "Formatting to FAT32" on page 26).
2	After connecting the USB memory stick all collected records will be stored to file data_log.csv in CSV format. Records won't be deleted from board so it is possible to get data onto several USB memory sticks.
3	When the display has shown the "Log" message and went back to default view, the log records have been stored successfully and the USB memory stick can be removed.

Data log uses 2KB of backup SRAM (under battery) for data records.

Interval for storing records is 3 hours. State change to fail mode also invokes record store.

If whole space is filled by record then new one will replace the oldest.

### Data log record content

Excel column	Output text	Description
Timestamp	<dd:mm:hh:ss>	Time for log since last compressor start sequence
T_amb	<-40....100>	Temperature of ambient air (-40 = Not conn.)
T_amb_int	<-40....100>	Temperature from internal RH/T sensor (-40 = Not conn.)
T_amb_ext	<-40....100>	Temperature from external RH/T sensor (-40 = Not conn.)
T_aux	<-40....100>	Auxiliary temperature (input) (-40 = Not conn.)
T_cond	<-40....100>	Temperature from condenser (-40 = Not conn.)
T_evap1	<-40....100>	Temperature from evaporator 1 (-40 = Not conn.)
T_evap2	<-40....100>	Temperature from evaporator 2 (-40 = Not conn.)
T_set	<5....34>	Setpoint value of desired temperature (Default OFF)
RH_amb	<0....100>	Humidity of ambient air (0 = Not conn.)
RH_amb_int	<0....100>	Humidity from internal RH/T sensor (0 = Not conn.)
RH_amb_ext	<0....100>	Humidity from external RH/T sensor (0 = Not conn.)
RH_set	<40....99>	Humidity set point (Default 60)
ExtFanSet	<40....99>	Extractor fan set point (Default OFF)
Service	[Blank]	Service interval disabled
	"ENABLED"	Service interval enabled
Mode	"SB"	Stand-by mode state
	"STARTUP"	Start-up mode state
	"DEH"	Dehumidifying state
	"ICE"	Deicing state
	"LP"	Low-pressure fail mode state
	"HP"	High-pressure fail mode state
	"SENS"	Sensor fail mode state
	"AMBT"	Ambient temperature fail mode
Error	"AMBRH"	Ambient humidity fail mode
	"EVAP"	Evaporator sensor Fail
	"COND"	Condenser sensor Fail
	"AUX"	Auxiliary sensor Fail
	"AMB_INT"	Internal ambient sensor error
Reason (For log)	"AMB_EXT"	External sensor error (Always shown when no conn.)
	"IDLE"	Automatically made every 3 hours
Sensor	"ERROR"	If an error occurred
	"SHT31"	New sensor type
	"ChipCap2"	Old sensor type



**Software update**

Follow these steps in order to update the software version.

Step	Action
1	Use an empty USB memory stick.
2	Obtain latest software version from Dantherm and copy the file to the USB memory stick.
3	Insert the USB memory stick in the USB port of the control panel of the unit.
4	The unit will now auto detect the new software and install it. The installation process should take no more than 30 seconds. During the process the display shows: "Erasing - Flashing - Done - Log" and a log file is stored on the USB memory stick.  <b>Note:</b> If the display only shows the "Log" message, when the USB is inserted and returns back to default view some seconds later, the software has NOT been updated successfully. The reason may be a wrong format of the USB memory stick. Try to format the USB memory stick to FAT32 (see description below) and repeat the software update procedure again.
5	When the display went back to default view the memory stick can be removed.

**Formatting to FAT32**

Format the USB memory stick to FAT32 file system by following the below steps.  
(Note: All data on the USB memory stick will be erased during the formatting process.)

Step	Action
1	Insert a USB memory stick in the USB port of the computer. Supports total drive volume of max 16Gb only.
2	Press WIN key (  )+r
3	Type: CMD - press enter
4	Type: format /FS:FAT32 X: - press enter.   X = letter of the USB drive
5	When you get the following message: Insert new disc for drive X: and press ENTER when ready - press enter.
6	When the disc has been formatted with a 100% - press enter to complete the formatting process.

## Trouble shooting

**Display messages** The CDP can display a number of Information and Error Messages to help finding a fault. Every single message and associated problems are explained in the following sections.

### Information messages

Display	Description
<i>AbRh</i>	The relative humidity is out of range. <ul style="list-style-type: none"> <li>The display will automatically return to standard view when the relative humidity is within range again.</li> </ul>
<i>Abt</i>	The ambient temperature is out of range. <ul style="list-style-type: none"> <li>The display will automatically return to standard view when the temperature is within range again.</li> </ul>
<i>LOSS</i>	The connection to the Remote Panel is lost. <ul style="list-style-type: none"> <li>When the connection is reestablished the error message can be cleared by pressing OK.</li> </ul>
<i>SEr</i>	It is time for service inspection. <ul style="list-style-type: none"> <li>When a new service interval is set, the display will return to standard view.</li> </ul>
<i>PAI r</i>	The unit tries to connect to a remote control. <ul style="list-style-type: none"> <li>The display will automatically return to standard view after some seconds.</li> </ul>
<i>LPCo</i>	Low Pressure preliminary warning <ul style="list-style-type: none"> <li>The unit will reset and returns to standard view, if the problem is solved after restart. If the error persists the display will switch to an LP error (see table "Error messages").</li> </ul>

### Error messages

Display	Description
<i>SEnS</i>	<p>This message indicates a sensor fault and will cause the unit to stop.</p> <p> Press either Up or Down to determine which sensor is faulty. The faulty sensor can be:</p> <p><i>COnd</i> Condenser sensor (displayed COnd)</p> <p><i>EUAP</i> Evaporator sensor (displayed EVAP)</p> <p><i>rh°t</i> Humidity sensor (displayed rh°t)</p> <p>If no button is pressed for 10 seconds it will return to SEnS.</p>
<i>LP</i>	If the Code LP (Low Pressure detection) is shown, the fault must be found and rectified. (See also "LED light and troubleshooting" on page 28)
<i>HP</i>	If the Code HP (High Pressure detection) is shown, the fault must be found and rectified. (See also "LED light and troubleshooting" on page 28)

The errors described above automatically lock the unit.



Press OK and access the unlock sequence in order to dismiss the error.

**Unlock Sequence**

**Loc** The message indicates that the unit is locked. If no buttons are pressed within 5 seconds the display will return to previous fail state.

Follow the steps below in order to unlock the unit.

Step	Action	Description
1		<b>UnLo</b> (unlock function) is displayed
2		<b>tEst</b> (test function) is displayed
3		test is activated. The test will detect if the error is fixed.  <b>CCCC</b> indicates that the error has been fixed and the unit is unlocked successfully.  <b>FAI L</b> indicates that the error is NOT fixed yet and the unit will still be locked.



**NOTICE**

If the dehumidifier is not functioning correctly, shut it down immediately!

**LED light and troubleshooting v.1.45 and prior**

Use this table to understand the LED lights or localize and solve a possible problem/ fault (v.1.45):

LED	Audible alarm	Reason
OFF	-	No power to PCB
Blue	Burst	Single 1s beep
	Slow flashing	-
	Constant	Single short beep every 1 min.
Green	Constant	-
Green/Yellow	Flashing	-
Yellow	Constant	Single short beep every hour
	Flashing	Triple beep every 10 min.
Yellow/Red	Flashing	Single short beep
Red	Constant	3 sec. beep
	Flashing	Double beep every 1 min.
		Single short beep every 5 min.

If you cannot find the reason for the fault, switch off the unit immediately in order to prevent further damage. Contact a service technician or a Dantherm representative.

**LED light and troubleshooting v.1.47**

Use this table to understand the LED lights or localize and solve a possible problem/ fault (v.1.47):

LED	Audible alarm		Reason
OFF	-	-	No power to PCB
Blue	Burst	Single 1s beep	Power up sequence
	Slow flashing	-	Self-test sequence activated. LED will blink until self-test has completed.
Green/Yellow	Flashing	-	Unit in remote pairing mode
Green	Constant	-	Unit operating normally
Yellow	Constant	-	Service timer expired. Perform service and set new interval
Red	2x flash	Single 3s beep	LP alarm. See fault finding guide page 31
	4x flash		HP alarm. See fault finding guide page 31
	6x flash		Sensor alarm. See fault finding guide page 31

If you cannot find the reason for the fault, switch off the unit immediately in order to prevent further damage. Contact a service technician or a Dantherm representative.

**Fault finding guide**

Display text	Type	Fault	Possible cause	Unit behaviour	Fault finding	Solution
None	-	-	Power supply disconnected Fuse 'F1' on main PCB blown	LED + display off	Check 230V supply Check PCB fuse	Re-establish power supply Replace fuse
Abt	Info	No fault	Ambient temperature is out of operating range	Unit in standby	-	-
Abrh	Info	No fault	Ambient humidity is out of operating range	Unit in standby	-	-

Display text	Type	Fault	Possible cause	Unit behaviour	Fault finding	Solution
LPCo	Alarm	LP condition	Refrigeration circuit leak causing loss of refrigerant	LPCo will persist until LP fault is triggered after 3 separate attempts to clear the fault condition. *Condition is similar to Expansion valve failure	* confirm compressor is running * confirm fan is running * confirm defrost valve is closed (no leak) --> No temperature difference between coils  compressor does not start at all: *Confirm there is voltage at compressor terminals.  compressor tries to start but will not run (clicking/humming from compressor): *Confirm that compressor voltage is 230V +/- 10 % *Confirm run capacitor is within specifications	Repair refrigeration circuit  Replace compressor"
			Compressor defective	LPCo will persist until LP fault is triggered after 3 separate attempts to clear the fault condition No or irregular noise from compressor housing		Replace compressor Replace run capacitor
			Thermostatic Expansion Valve (TEV) defective	LPCo will persist until LP fault is triggered after 3 separate attempts to clear the fault condition. Evaporator coil can build up a small amount of ice around the TEV  * condition can be similar to refrigeration circuit leak	Verify if TEV is visually damaged: Check for cracks and/or corrosion in TEV head / capillary tube / TEV sensor bulb	Replace TEV
			*Defective temperature sensor for evaporator coil or condensor outlet tube. *Bad contact to evaporator coil / condensor outlet tube *Bad connection in plug on PCB *PCB failure *Sensor wire break	Unit seemingly functions normally with no apparent fault. Evaporator coil cold, condenser coil warm.  Permanent or periodic LP failure	Confirm sensor resistance Check connection to PCB for corrosion Confirm sensor wire integrity  Sensor resistance and connection OK --> defective PCB	Replace sensor Clean connection to PCB Perform PCB reset procedure Replace PCB
			Special operation conditions: Ambient temperature and humidity low can cause insufficient temperature difference between condenser and evaporator coil, which will trigger LPCo fault	No or limited water from dehumidifier LPCo fault will be periodically present LP fault can be triggered  Self check will reset fault condition	"Confirm compressor is running Confirm fan is running Confirm magnetic defrost valve is closed (no leak)"	Perform self check Wait for room temperature to increase
			Defrost valve leak PCB failure causing incorrect operation of defrost valve	No water from dehumidifier LPCo will be periodically present LP fault can be triggered	Hissing from defrost valve Voltage at defrost valve coil when there is no ice on evaporator coil"	Exercise valve by means of external magnet or by applying 230VAC to valve coil Replace defrost valve Perform PCB reset procedure Replace PCB

Display text	Type	Fault	Possible cause	Unit behaviour	Fault finding	Solution
LP	Alarm	LP fault	LPCo fault has been triggered too many times consecutively	LP fault is triggered.	See LPCo fault finding procedures	-
			Fan failure, periodic	HP fault is triggered Unit seemingly operating normally, self check will reset fault condition	Confirm fan is working. If fan switches off for no apparent reason it is likely caused by the internal fan motor thermal protection circuit. It will disable the fan if the winding temperature is too high.	Replace fan
			Fan failure	HP fault is triggered. Self-test will not reset the fault condition	Confirm fan is working.	Replace fan
HP	Alarm	HP fault	HP temperature sensor fault	HP fault is triggered self check will not reset fault condition	Measure resistance of the temperature probe between the "cond" and "gnd" terminals in the "temp" section of the PCB. Resistance should be in the range 190kOhm - 0,14kOhm, corresponding to -50..98°C.  If resistance is not within this range the sensor is defective or sensor cable is broken/short circuited	Replace temperature sensor
			Condenser coil clogged		Inspect condenser coil fins for dust/debris.	Clean condenser coil
SENS	Alarm	Sensor failure	Sensor malfunction	Display shows SENS error followed by EVAP or COND when arrow keys are pressed, indicating fault in either condenser or evaporator sensor	Measure resistance of the temperature probe between the terminals of the corresponding sensor in the "temp" section of the PCB. Resistance should be in the range 190kOhm - 0,14kOhm, corresponding to -50..98°C.  If resistance is not within this range the sensor is defective or sensor cable is broken/short circuited	Replace temperature sensor
LOSS	Info	-	Lost communication to paired remote control panel	Display shows SENS error followed by Rh*t when arrow keys are pressed indicating failure of the combined temp./RH-sensor.	Confirm if the sensor and/or cable is visibly damaged.	Replace sensor
					Check that remote control panel is On. Check batteries in remote control panel.	Move display closer. Change batteries in remote control panel.



## Spare parts

---

### Find spare parts

If the need for spare parts occurs, please visit: [shop.dantherm.com](https://shop.dantherm.com)

---



## Schematics

### Cooling circuit

#### Illustration

This illustration shows the cooling circuit of the CDP/CDP-T range.

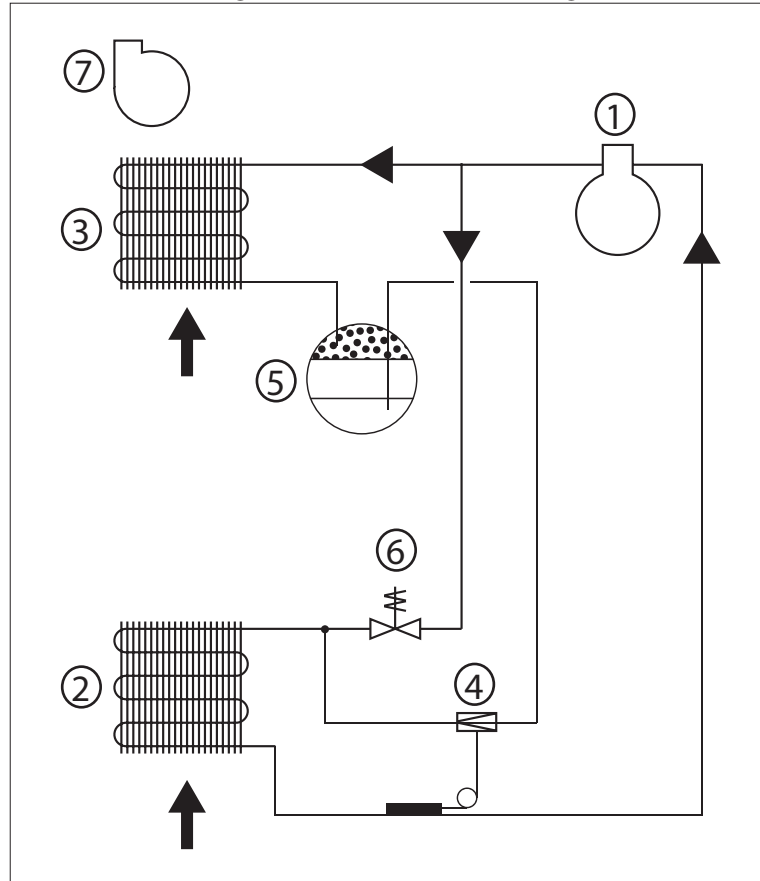

Fig. 9

#### Description

This table lists the different parts of the cooling circuit according to Fig. 9.

Pos.	Description
1	Compressor
2	Evaporator
3	Air-cooled condenser
4	Thermostatic expansion valve
5	Receiver/liquid line drier
6	Solenoid valve for pressure equalization
7	Fan

Main PCB

Illustration

This illustration shows the main PCB and its terminals.

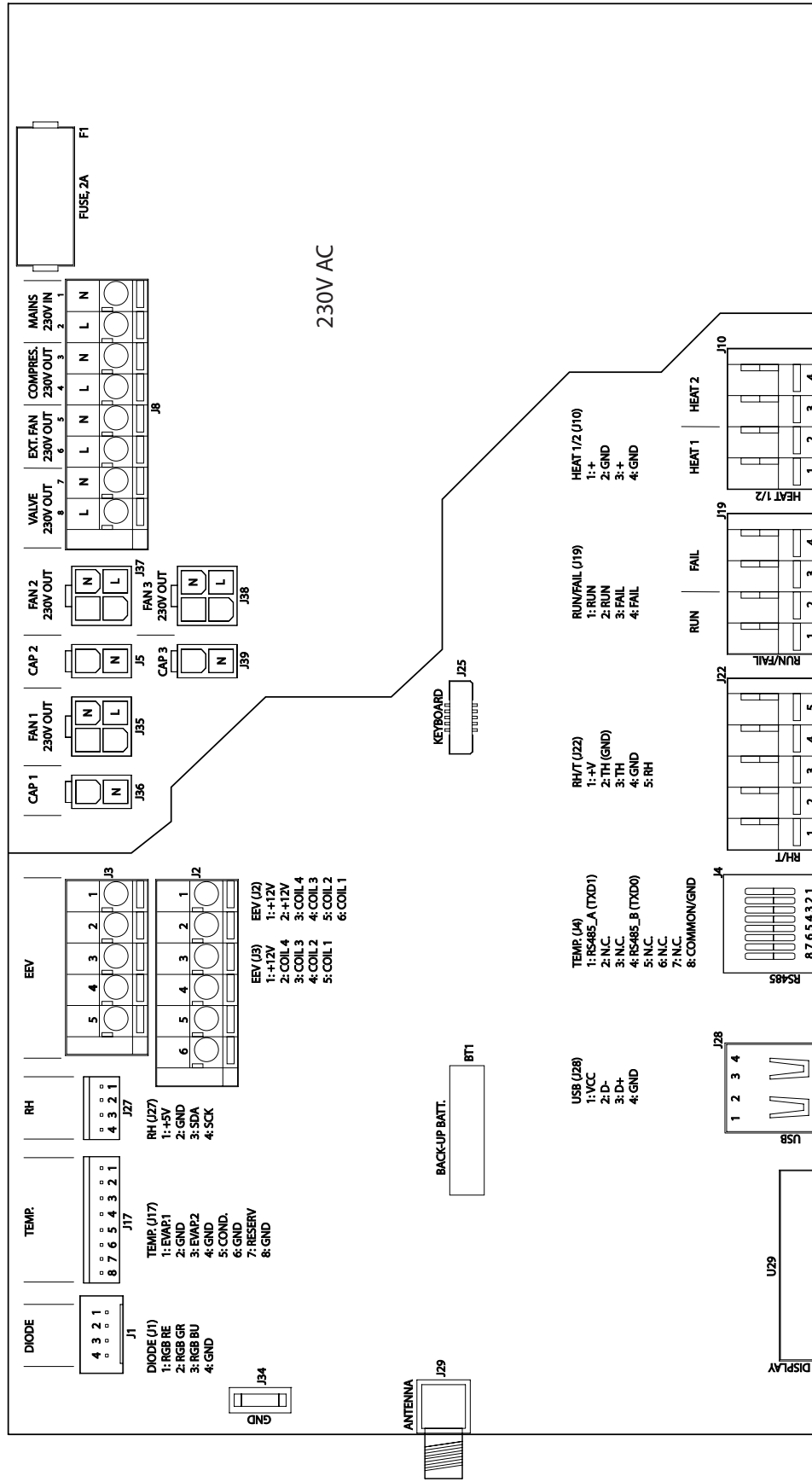

Fig. 10

# Wiring diagram

## Illustration

This illustration shows the standard connection of the unit.

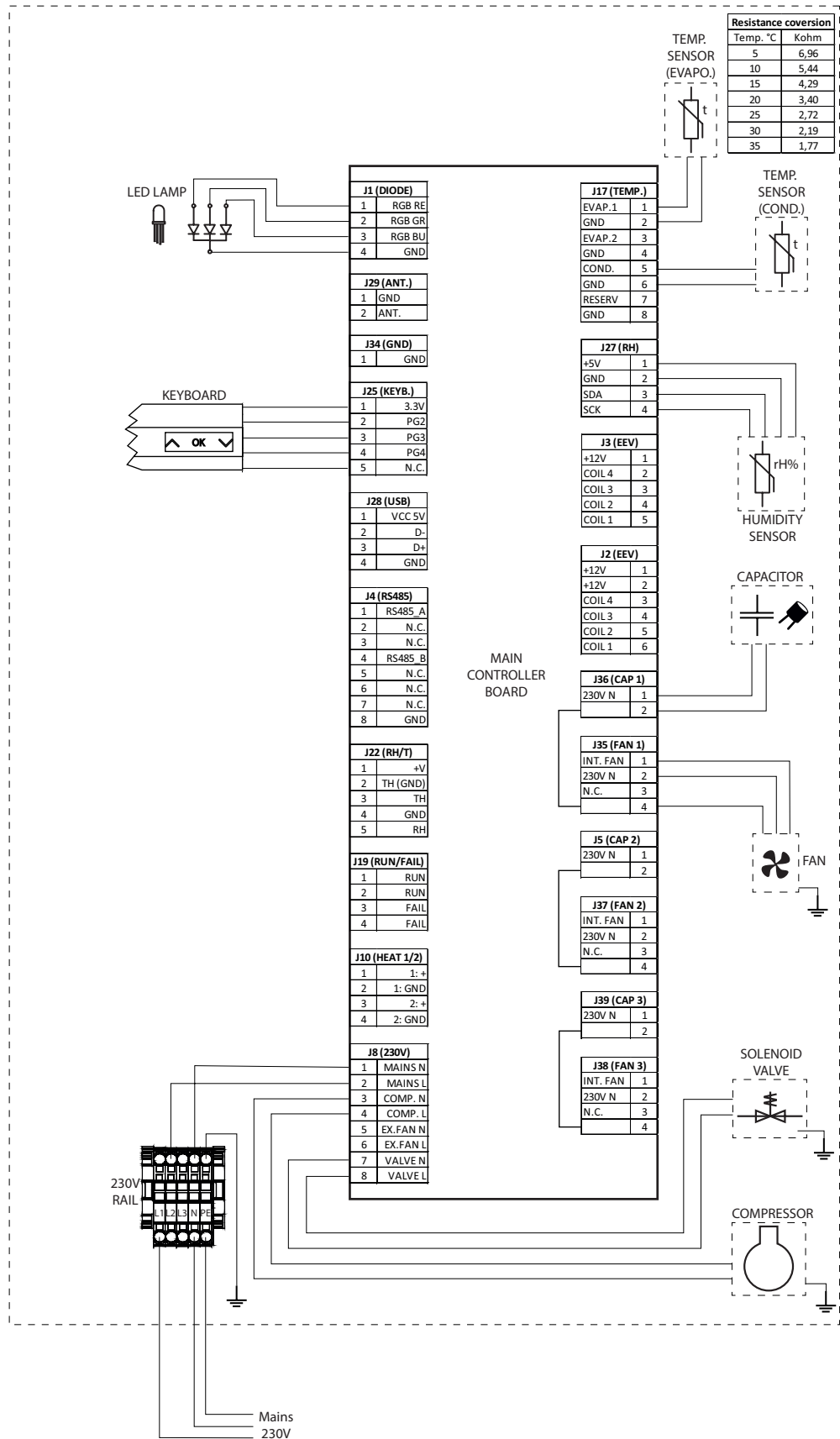

Fig. 11











**Dantherm A/S**  
Marienlystvej 65  
7800 Skive  
Denmark

[support.dantherm.com](http://support.dantherm.com)



094017

---

Dantherm can accept no responsibility for possible errors and changes (en)

Der tages forbehold for trykfejl og ændringer (da)

Irrtümer und Änderungen vorbehalten (de)

Dantherm n'assume aucune responsabilité pour erreurs et modifications éventuelles (fr)

