



CDP 85-135-175
SERVICE MANUAL

| en |



116540

Rev. 1.8 - 2024-04-22

Table of contents

Introduction	4
Symbols used in the operating instructions	5
Safety	6
Product and functional description	7
Dimensions of the units	8
Display	11
Description of the icons	11
Default view and navigation	12
Main display layout	12
Display and menu overview	13
Menu overview	13
Settings	15
Other control options	17
External RH/T sensor	17
Dew point sensor	17
De-icing sequence	17
Ice build-up prevention	17
HP-prevention	17
Mounting and installation instructions	18
Placing of CDP 85, 135, 175	18
Air outlet through the top	19
Changing the inspection side	19
Duct connection	19
Outdoor air duct connection	20
Maximum quantity of outdoor air	20
Water heating coils	20
Electric heaters	20
Connection of water heating coils	20
Water-cooled condenser connection	20
Water cooling coils	20
Connection of water cooling coils	20
Connection of water-cooled condenser	21
Connection of mains supply	21
Main power supply	21
Adding chemicals	21
Self-production of chlorine	21
Langelier Saturation index	21
Service guide	22
Fault finding guide	23
Fault finding	23
Cooling diagram	26
Schematics of cooling diagram	26
Wiring diagram CDP 85-135, 230V	27
Wiring diagram CDP 135-175, 3x400V	28
Technical information	29
Technical data	29
Spare parts	30
How to order	30
Disposal	31
Disassembly	31
CE - Declaration of Conformity CDP 85	32
CE - Declaration of Conformity CDP 135, CDP 175	33

Introduction

General information

This is the service manual for the CDP-85-135-175.
The control strategy and configuration of the units through the touch display will be covered in this manual.
This section provides general information about the unit and this Service Manual.

User groups

This Service Manual is for the technicians who install, maintain and repair the unit

Accessibility

The unit may be placed where it is accessible to the general public

Products

This Service Manual covers the following products:

Name	Type no.
CDP-85-135-175	351590, 351591, 351592

Copyright

No part of this manual may be reproduced without the prior written permission of the manufacturer.

Recycling

This unit is designed to provide a long service life. At the end of its service life, the unit must be recycled in accordance with national regulations and with high environmental protection considerations. The dehumidifier contains R454C refrigerant and compressor oil. The compressor must in connection with disposal be returned to authorities.

Reservations

The manufacturer reserves the right to make changes and improvements to the product and the manual at any time without any obligation to give prior notice.

Quality Management System

The manufacturer has implemented a quality management system in accordance with EN/ISO9001. The system is supplemented with an environmental management system in accordance with EN/ISO14001.

WARNING

It is the responsibility of the operator to read and understand this service manual and other information provided and to use the correct operating procedure.

Read the entire manual before the initial start-up of the unit. It is important to know the correct operating procedures for the unit and all safety precautions to prevent the possibility of property damage and/or personal injury.

Abbreviations in this document

Abbreviations	Description
kWh	Kilowatts per hour
SerNo.	Serial number
Rh	Relative humidity
Ah	Absolute humidity
DewP	Dew point
VOC	Volatile organic component
AuxT	Auxiliary temperature
EC	Electronically commutated
LP	Low pressure
HP	High pressure
Occ	Occupied
UnOcc	Unoccupied

Symbols used in the operating instructions

In these operating instructions, particularly important text passages are highlighted with signal words and symbols that are described below.

DANGER

...indicates a hazard which, if not avoided, will result in death or serious injury.

WARNING

...indicates a hazard which, if not avoided, could result in death or serious injury.

CAUTION

...indicates a hazard which, if not avoided, could result in a minor or moderate injury.

NOTE

...indicates important information (e.g. property damage) but does not indicate hazards.

INFORMATION

...information marked with this symbol helps you to carry out your tasks quickly and safely.

Hazard symbols



This symbol is used to warn you of potential risk of injuries. Follow all safety instructions indicated in the manual next to the warning triangle to avoid potential injury or death.



Electrical voltage

This symbol indicates that there are dangers to the life and health of persons due to electrical voltage when handling the system.



Protective gloves

This symbol indicates that it is required to wear protective gloves when performing a specific operation.



Protective mask

This symbol indicates that it is required to wear a protective mask when performing a specific operation.



Disconnect from mains

This symbol indicates that the plug of the unit should be pulled/disconnected from the mains.

Safety

Note! Read carefully before use. Keep for future reference.

It is the responsibility of the operator to read and understand this manual and other information provided and to apply the correct operating procedures.

Read the entire manual before starting up the unit for the first time. It is important to be familiar with the correct operating procedures for the unit and all related safety precautions to avoid the risk of personal injury and/or property damage.

Safety instructions The following safety instructions must be observed:

- Ensure that all electric cables outside of the unit are protected from damage (e.g. caused by animals). Never use the unit if electric cables or the power connection are damaged!
- Only apply power when the supply cable is properly fused (earthed).
- Only install the unit in accordance with the national regulations for electrical connection.

Before carrying out maintenance, care or repair work on the unit:

- Observe the operating conditions specified in the “Technical information” chapter.
- Check accessories and connection parts for possible damage prior to every use of the unit. Do not use any defective units or unit parts.
- Do not cover any air intakes or outlets at any point – except with accessories intended for this purpose.

NOTE

The unit does not have an integrated safety switch. In case a safety switch is required due to regulations, the safety switch must be added by the installer

WARNING

Risk of fire or explosion!

Flammable refrigerant used

- Repair and disposal must be carried out by trained service personnel
- No naked flame allowed during service or repair

Foreseeable misuse

Any operation other than as described in this manual is prohibited. Non-observance renders all claims for liability and guarantee null and void.

If any unauthorised modifications are made, any claims for liability and guarantee are rendered null and void.

Personnel qualifications

Dehumidifiers may be accessible to the general public, but repair of the cooling circuit and the electrical system is to be performed by qualified personnel only.

Failure to do so may result in personal injury or damage to the equipment.

Stage of life	Activity	Target group
Installation		Qualified personnel
Operation		Qualified personnel
Maintenance	Monthly maintenance activities	Operating personnel
	Annual maintenance activities	Qualified personnel
Repair		Qualified personnel

Product and functional description

Illustration Illustration of the functional principle of the CDP 85/135/175

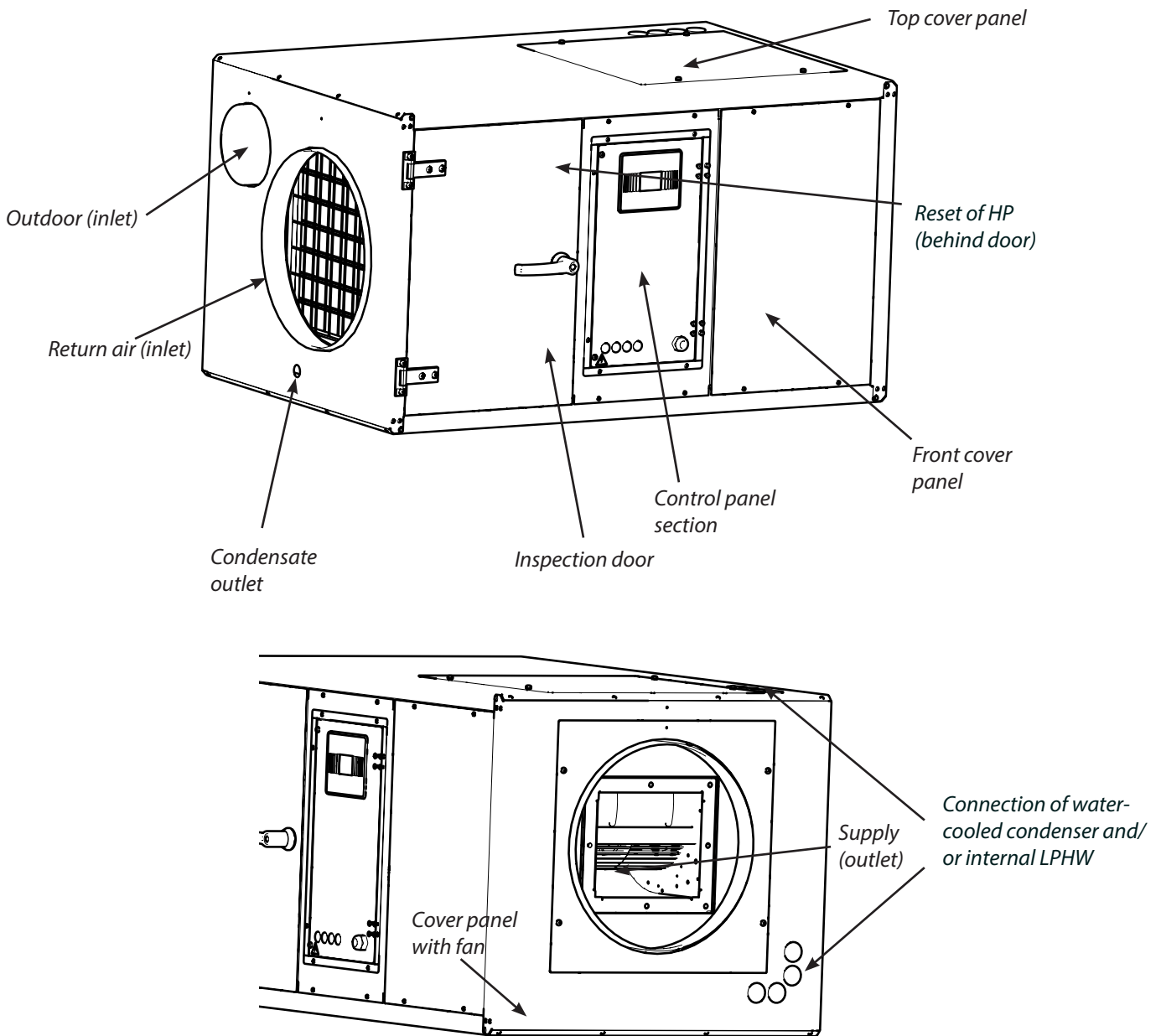

Fig. 1: CDP

Functionality of the dehumidifier

The CDP 85/135/175 utilize the condensation principle.

The humid air is drawn into the unit by a fan.

In the evaporator the air is cooled to below the dew point, the water vapour condenses into liquid, which is led to a drain.

The heat extracted from the return air through the evaporator and the applied work by the compressor, are recovered by the supply air through the condenser, resulting in an increase in temperature compared to the return air temperature at the inlet. Warm dry air is thereby reintroduced to the room.

The repeated circulation of air through the unit reduces the room's relative humidity, resulting in very rapid but gentle drying.

Dimensions of the units

CDP 85

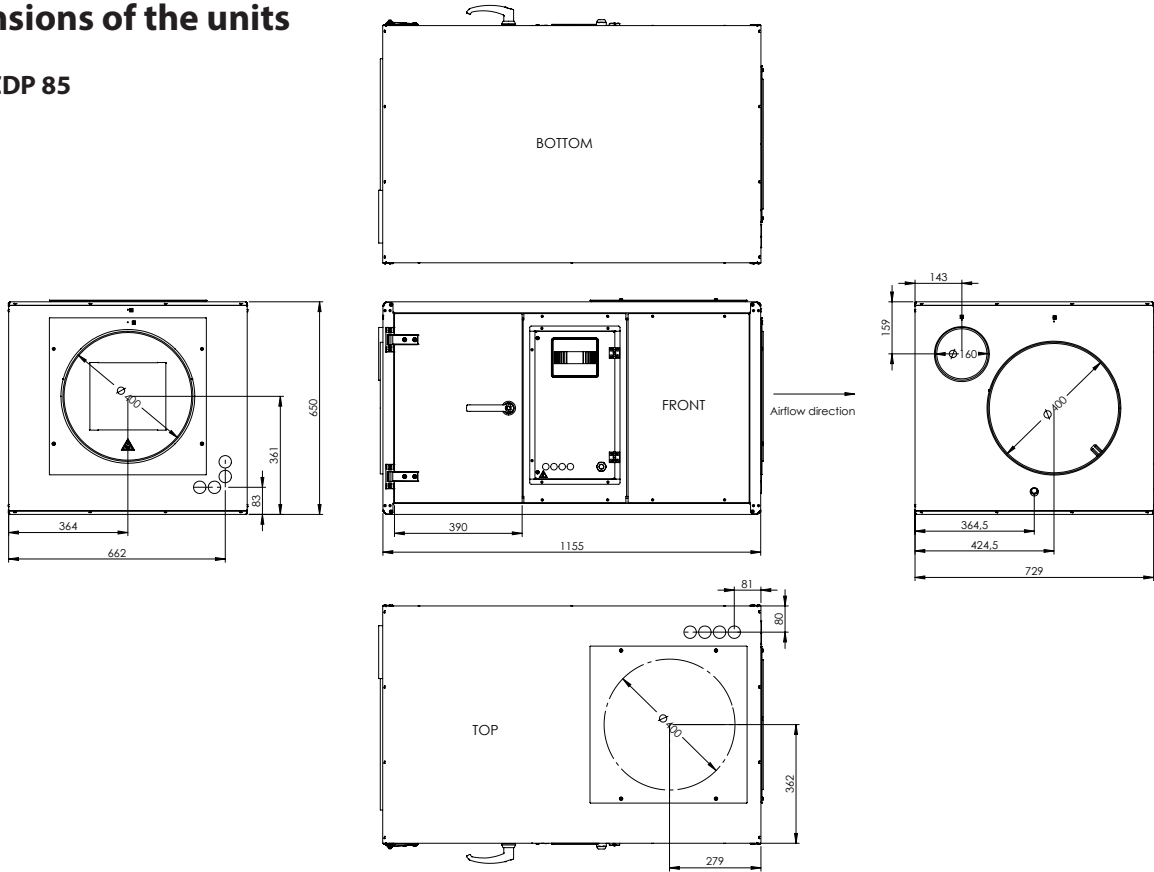

CDP 135

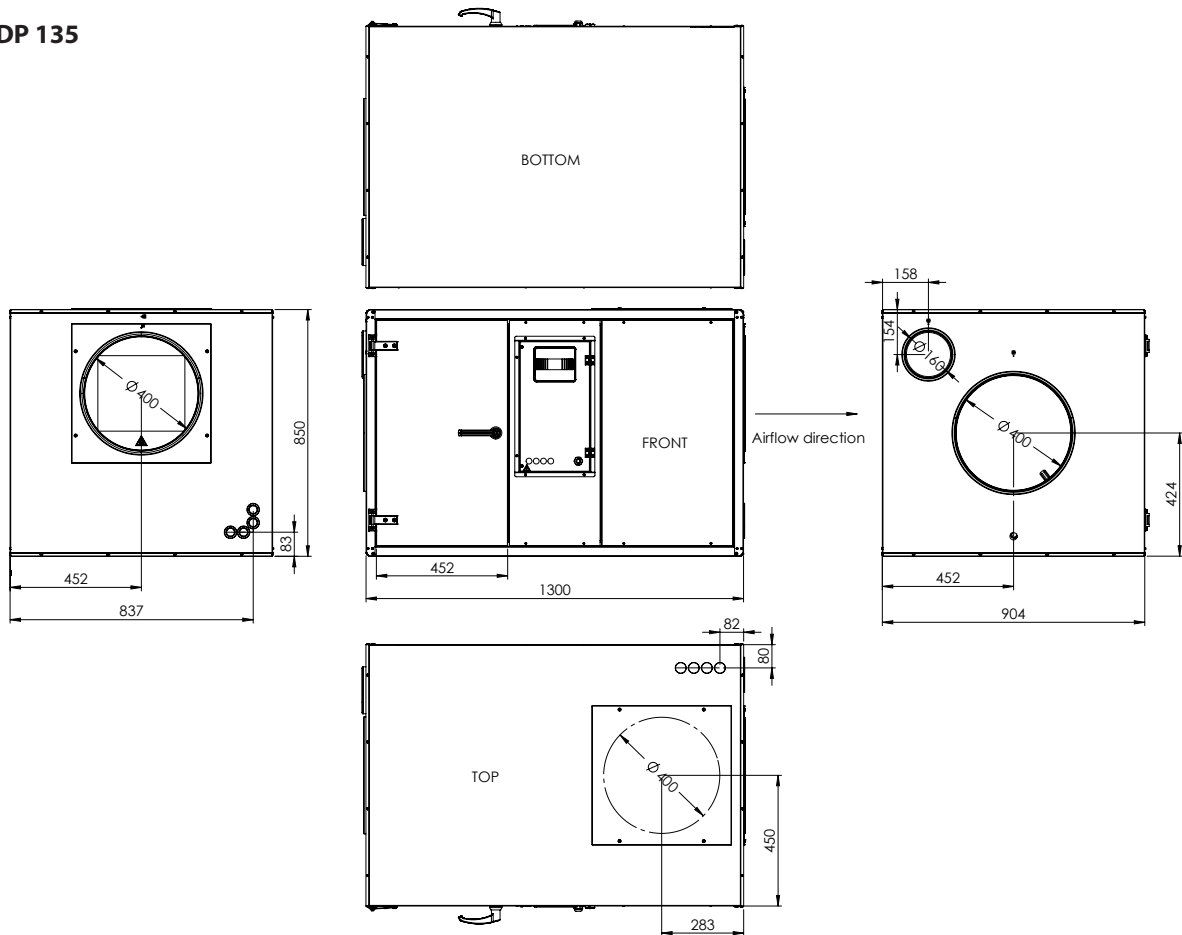

Product and functional description: Dimensions of the units

CDP 175

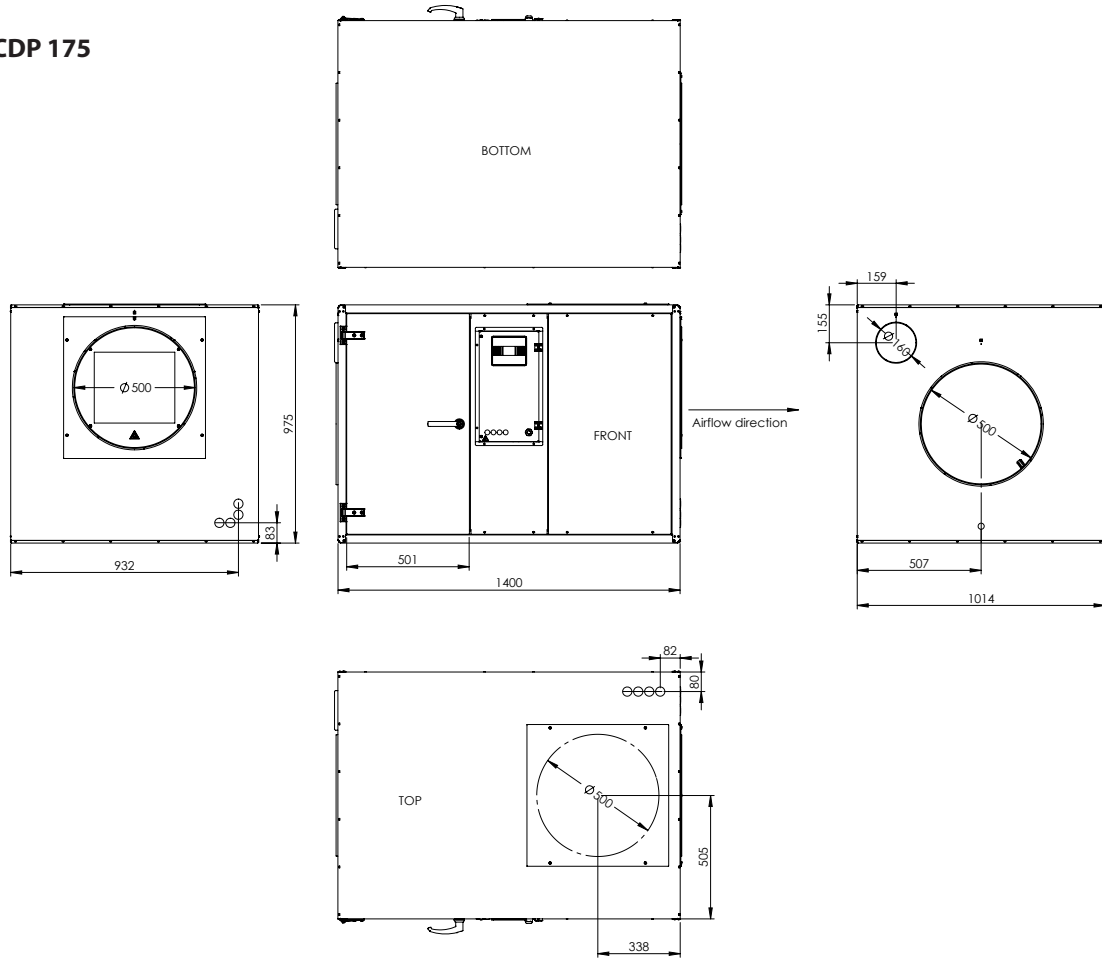

Product and functional description, *continued*

Fan

Three fan modes are available:

Sense mode: When the dehumidifier is on standby, the fan will start every 15 minutes for 1 minute to circulate the room air over the internal sensor element. Is used if installation has long air ducts.

Continuous mode: Fan runs continuously to circulate room air.

Intermittent mode: Fan runs only when heating, cooling or dehumidification is active. If installation has long return air ducts, use external RH/T room sensor.

Compressor

The time between compressor start-ups is limited by a 10 minutes timer, where the compressor must run for minimum 6 minutes, and must be off for minimum 4 minutes before it is started again.

The restart timer will prevent instant start of compressor when power is switched on.

The timers protect the compressor against overloading caused by too frequent starting cycles.

HP pressostat

The dehumidifiers are fitted with a HP pressostat with manual reset. The HP pressostat can be located by opening the inspection door from the front side of the dehumidifier, where the touch panel is located.

Note that it is not possible to relocate the HP pressostat if the inspection side is switched around. A soft HP/LP function has also been implemented to protect the system. If the soft HP/LP function is activated, the system will stop for a fixed duration before attempting to return to normal operation. If the soft HP function has been activated 6 times within an hour, the compressor will be blocked from starting again until reset. The soft LP and HP function will automatically be reset by the controller unless it is activated 6 times within an hour, which requires manual reset.

Schrader valves

The unit is fitted with 'Schrader' type service valves on the LP side of the cooling circuit.

CAUTION

The equipment has to have means of disconnection from power supply according to the local regulations.

The power cord must comply with local legislation, where the equipment is used.

If the supply cord is damaged, it must be replaced by the manufacturer, its service agent or similarly qualified persons in order to avoid a hazard. Only connect power via a properly earthed power cable that is fused according to relevant regulation.

Display

Display

The inspection side of the unit has a touch display panel with a graphical user interface.

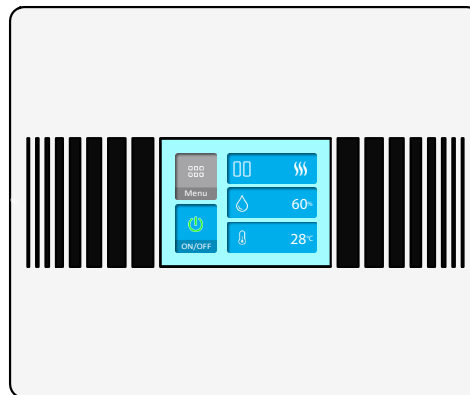

Fig. 2: Default display

Icons

The icons in the display panel indicate various operation modes. When a blue icon turns grey after pressing it, it means the function is turned off. Selecting it again activates the function. An overview of the description of the icons is given below.

Description of the icons

The following table gives an overview of the meaning of the icons in the display:

Icons	Description	Icons	Description
	Active		Settings
	Pause		Temperature
	Stop		Unlock set value
	ON/OFF switch (ON state)		Move up or increase selected value
	ON/OFF switch (OFF state)		Move down or decrease selected value
	De-icing ongoing		Confirm
	Dew point		Alert/error
	Fan ON		Heating ON
	Unoccupied mode		Service timer expired
	Language		High pressure error (soft)
	Room RH/Temperature		Low pressure error (soft)
	Compressor in pause mode		Wireless connection
	Relative humidity %		Cooling ON
	Information		Fresh air
	Set value lock		Exit
	Menu		

Default view and navigation

Main display layout

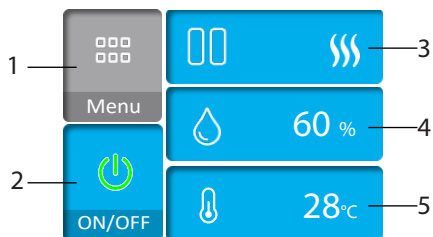

Fig. 3: Main display layout in RH control mode

Item	Button/Indication	Description
1	Menu	Select the menu button to navigate to the screen in figure 3
2	ON/OFF	Turns the device ON and OFF
3	Status	Indicates the current status of the device
4	Humidity	Shows the actual relative humidity in percent in the room. Press to navigate to the screen in figure 4, where the desired RH setpoint can be adjusted.
5	Temperature	Shows the actual temperature in °C in the room. Press and navigate to the screen in figure 5, where the desired temperature setpoint can be adjusted.

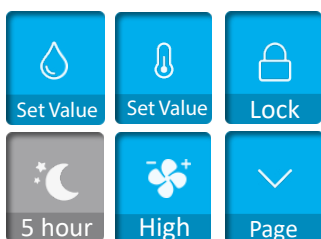

Fig. 4: Submenu display layout

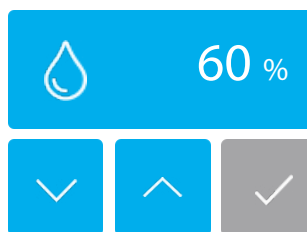

Fig. 5: Set Value display layout

Setpoint humidity: 40 - 100%

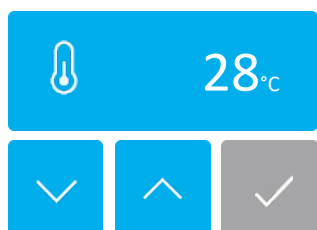
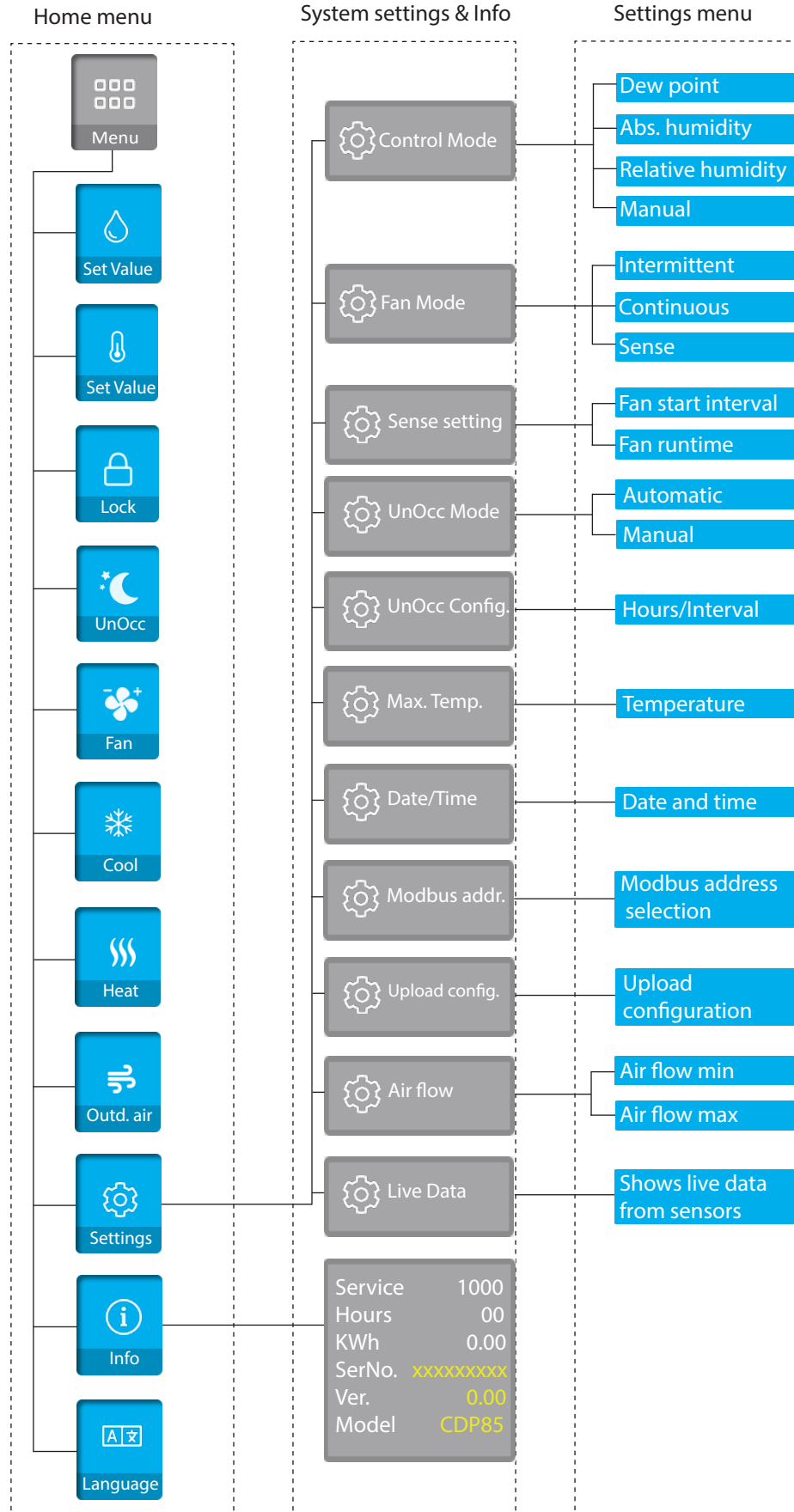

Fig. 6: Set Value display layout

Setpoint temperature: 0 - 38°C

Display and menu overview

Menu overview



Display and menu overview, *continued*

Humidity control settings



The relative humidity setpoint can be adjusted by selecting the up and down arrows. It is not possible to deactivate dehumidification using this function.

Temperature settings



The temperature setpoint can be adjusted using this function. Adjust the temperature by selecting the up and down arrows.

Lock mode



Here you can lock the settings. Setpoint is locked and cannot be adjusted from the main screen without unlocking.

UnOcc mode settings



When UnOcc mode is activated, the dehumidifier will run at low fan speed for a time interval or fixed time, depending on which night mode is selected. To use this function, the current date and time must be set.

Fan



This function selects high or low fan speed. It is not possible to deactivate the fan using this function. The EC centrifugal fan utilizes a build-in constant flow regulation of the airflow. The user may define a min./max. volumetric airflow within the specified range of the given product.

External cooling ON/OFF



A cooling unit can be connected to reduce the room temperature. Disable/enable the cooling signal by pressing the button. Select Temperature settings in order to adjust the temperature setpoint. Remember to activate the cooling control signal through the menu when a cooling coil is connected.

External heating ON/OFF



A heating unit can be connected to ensure that a heating demand is satisfied. Disable/enable the heater signal by pressing the button. Select Temperature settings in order to adjust the temperature setpoint. Remember to activate the heating control signal through the menu when a heating coil is connected.

Outdoor air ON/OFF



An outdoor air duct can be connected to the dehumidifier to satisfy minimum outdoor air requirements of min. 15%. Disable/enable the outdoor air ON/OFF signal by pressing the button. The signal may be utilised to activate/deactivate a damper and/or exhaust fan within the room. Remember to activate the outdoor air signal through the menu when the outdoor air duct is connected.

Display and menu overview, *continued*

Settings

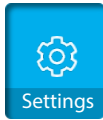

You can make the following settings:

Menu Item	Setting/Value	Description
Control Mode	Dew point	Dew point control via ext. sensor
	Abs. humidity	Absolute humidity control
	Relative humidity	Relative humidity control
	Manual	Dehumidification always ON
Fan Mode	Intermittent	Fan only runs when a demand for dehum. or heat/cooling is present (ext. sensor recommended)
	Continuous	Fan is running continuously
	Sense	Fan will run periodically
Sense Timing	5-30	Time interval between fan start sensing, in minutes
	1-10	Duration for fan sensing mode, in minutes
UnOcc. Mode	Automatic	Fan runs at min. speed for a defined time
	Manual	Fan runs at min. speed for a number of hours after activation
UnOcc. Config.	Hours	Duration of UnOcc. mode
Max. Temp.	Maximum operational temp.	Set the maximum ambient temperature
Date/Time	Date and time	Set the date and time for the unit
Modbus addr.	Modbus address selection	Set modbus address for the unit
Upload config.	Upload configuration	Upload new configuration from MicroSD card
Air flow	Air flow minimum	Set the minimum air flow for the unit
	Air flow maximum	Set the maximum air flow for the unit
Live Data	Shows live data of sensors	Various live engineering and operational data of the unit

Info

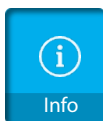

The information menu shows the following:

Menu Item	Description
Service	Timer indicating the next (user specified) service
Hours	Number of hours the compressor has been running
kWh	Function is not active in this product
SerNo.	The serial number of the unit
Ver.	The version of the software
Model	The name of the unit model (eg. CDP 85)

Language settings



No other languages other than English are currently available.

Display and menu overview, *continued*

Error warning



If the unit experiences an error in any of the functions, a warning will appear in the display. The error warnings will correspond to any of the following:

Menu Item	Description
LP Error	The LP error is activated when the temperature difference between the condenser and evaporator coil is less than 5°C ($T_c - T_e < 5^\circ\text{C}$). This is indicative of a loss of refrigerant in the circuit, but the LP Error can also be activated by other faults such as HP switch trip, compressor malfunction or TEV malfunction. See fault finding section for further information. If the LP Error is activated the dehumidifier is stopped and blocked from automatic operation pending user intervention. After troubleshooting the cause of the LP Error the unit can be restarted by pressing the "ON/OFF" button in the touch display.
HP Error	When condenser coil temperature exceeds the software HP setting the HP Error will be activated. The HP Error is configured to disable the dehumidifier before the pressure in the refrigeration circuit exceeds the trip limit of the mechanical HP switch. Once the HP Error is active the unit stops and goes into pause state to cool down and the HP counter is incremented. When the condenser coil temperature has decreased to more than 10°C below the software HP setting the HP Error is reset automatically. The dehumidifier will be able to resume operation again once the cool down timer has expired. If the HP Error occurs 5 consecutive times the dehumidifier is stopped and blocked from automatic operation pending user intervention. After troubleshooting the cause of the HP Error the HP counter is reset by the user by pressing the "ON/OFF" button in the touch display. Remember to verify if the mechanical HP switch has also been tripped.
Low Tempr.	Ambient temperature less than specified operating range. Dehumidifier will not run until ambient temperature increases.
High Tempr.	Ambient temperature higher than specified operating range. Dehumidifier will not run until ambient temperature decreases.
C. Sensor	Condenser coil temperature sensor malfunction / sensor value out of range. Short circuit or wire break / bad connection.
E. Sensor	Evaporator coil temperature sensor malfunction / sensor value out of range. Short circuit or wire break / bad connection.
RH Sensor	RH sensor malfunction. Fault on I2C communication to controller.

See Fault finding guide for further information.

Other control options

External RH/T sensor

The control is prepared for the connection of an external RH/T sensor, which is placed in the room to be dehumidified or in the supply air duct – (air inlet).
The external RH/T sensor is available as an accessory.

Dew point sensor

An external NTC temperature sensor can be connected as a dew point sensor.
This sensor can be attached to any cold surface to prevent condensation.
The dehumidifier will automatically keep dew point below the cold surface temperature.

De-icing sequence

When the evaporator sensor registers a temperature below 5°C, the control interprets this as ice building up on the evaporator coil and lets the unit run for another 30 minutes. If the evaporator sensor still registers below 5°C after the 30 minutes have passed, the compressor then stops and the fan draws in warm air from the room to de-ice the evaporator until the evaporator sensor registers that the temperature is above 5°C.

Ice build-up prevention

The fan speed is automatically adjusted to minimize ice build-up in the evaporator at low ambient temperature. When the evaporator coil temperature drops below 3°C the fan speed will increase gradually until it reaches full speed to raise the evaporator temperature and prevent the forming of ice. When the evaporator coil temperature exceeds 5°C the fan speed will gradually decrease to the chosen setting.

HP-prevention

The fan speed is automatically adjusted to prevent HP Error due to high ambient temperature when running at reduced fan speed setting. When the condenser coil temperature is less than 10°C below the software HP setting the fan speed will automatically increase to prevent HP Error. The fan speed will increase until it reaches maximum speed. If increase is insufficient the HP Error will be activated and the unit stops automatically. See 'HP Error' description.

Mounting and installation instructions

Introduction This section contains all necessary information for correct mounting of the dehumidifier. The electrical installation is described at the end of this section.

Placing of CDP 85, 135, 175 CDP 85, 135, 175 can be placed in one of the following ways:

Placement	Comments
Floor	The dehumidifier can be placed directly on the floor. Make sure that there is sufficient space for the drain outlet and the water trap.
Footstands	The dehumidifier can be placed on shock absorbing footstands. The footstands are available as accessories on request.
Suspension brackets	When mounting the units onto a wall, it is recommended to fit oscillation dampers between the unit and the suspension brackets. The suspension brackets are available as options on request , expect for the largest unit.

NOTE

When placing the dehumidifier, unimpeded access to the inspection door should be ensured.
When the unit has been mounted, the handles are to be fixed to the inspection door.

Condensate outlet

The condensate outlet is located on the air inlet side. The dehumidifier is delivered with a 0.5 meter water hose, which is fixed to the 3/4" connector using the clip delivered with the hose. Make sure that the unit is mounted horizontally to ensure correct function of the condensate outlet.

NOTE

The hose from the unit to the external drainage must have at least a 2° decline.
Optimally, the drainage pipe has to be fitted with a water trap to prevent air getting sucked in through the pipe.
As an alternative, a condensate pump can be fitted at the water outlet to pump the water to a drain.

Mounting and installation instructions, *continued*

Air outlet through the top

Depending on the design of the plant room, it is possible to blow the warm dry air out through the top of the unit. In that case, the fan must be moved from the end to the top. It is done as follows:

Step	Action
1	Remove the fan cable and loosen it from terminals 5/6 in the control panel
2	Remove the cover panel with the fan fixed to it
3	Remove the top cover panel
4	Refit the cover panel with the fan to the top of the unit
5	Refit the top cover panel to the front of the unit
6	Connect the fan cable to the terminals in the control panel

Changing the inspection side

The inspection side of the unit can be changed to the opposite side. It is done as follows:

Step	Action
1	Remove the rear cover panel
2	Remove the inspection door and the cover panel on the front of the unit
3	Remove the middle control panel section and move it through the unit to the rear side
4	Remount the inspection door and the cover panel on the rear of the unit
5	Remount the cover panels on the front of the unit

Duct connection

The inlet and outlet ducts and any inlet and outlet grilles, must be dimensioned so that external back pressure never exceed the values mentioned in the table below. If pressure losses are higher, there is a danger of the unit cutting out via the high-pressure presostat due to insufficient air flowing over the condenser.

	CDP 85	CDP 135	CDP 175
Pa	300	350	450

Mounting and installation instructions, *continued*

Outdoor air duct connection On the air inlet side is an opening for connection of a fresh air duct. The opening is covered by a cover, which has to be removed before connecting the fresh air duct. If a fresh air duct is connected, we recommend that an external air exhaust fan is mounted for drawing out the extra air in order to maintain a negative pressure difference in the room and to avoid moisture and chlorine-containing vapours diffusing through the walls. An external exhaust fan for maintaining the negative pressure difference due to the introduction of outdoor air may be connected on X1 terminal points 3 and 4 on the PCB together with the outdoor air damper. The external exhaust fan will then start along with the fresh air damper. Maximum load on points 3 and 4 is 2 A.

Maximum quantity of outdoor air The quantity of outdoor air should not exceed the values mentioned in the table below. Too much outdoor air, particularly during winter, could lead to ice formation on the evaporator.

	CDP 85	CDP 135	CDP 175
m ³ /h	225	375	540

Water heating coils The CDP 85, 135, 175 can be fitted with low pressure hot water heating coil (LPHW). Depending on the desired solution, an internal or external LPHW can be installed together with the unit. The internal LPHW is designed for installation inside the unit, where as the external is a box build duct mounted LPHW. The technical specifications for the water heating coils are given in the table in the Service section.

Electric heaters The CDP 85, 135, 175 can be fitted with electric heaters. The electric heaters are designed for installation in the unit.

Connection of water heating coils The control signal for the LPHW coil control valve can be connected to X1 terminal points 5 and 6. Control output is 230V/2A. The control valve will be switched on and off automatically depending on the heat demand.

Water-cooled condenser connection A water-cooled condenser may be fitted allowing transfer of the excess heat from the supply air to a water source instead of the room air. CDP 85, 135, 175 with water-cooled condenser are supplied with coupling pipes (Ø15 mm). The coupling pipes can be coupled together with PEX pipes by means of clamping ring fittings. The technical specifications for the water-cooled condenser are shown in the Service section.

Water cooling coils The CDP 85, 135, 175 can operate in series with an externally duct mounted low pressure cooling water coil (LPCW). The cooling coil should be fitted on the supply air side at a recommended minimum distance of 1.0 meter to the previous component (eg. outlet of the dehumidifier).

Connection of water cooling coils The control signal for the LPCW coil control valve can be connected to X1 terminal points 1 and 2. Control output is 230V/2A. The control valve will be switched on and off automatically depending on the cooling demand.

Mounting and installation instructions, *continued*

Connection of water-cooled condenser

The water-cooled condenser is normally activated by a temperature controlled water pump, which starts up automatically when it reaches a specified room temperature and pumps water through the condenser. Alternatively, the cooling signal from the dehumidifier may be applied. A 230V/2A cooling signal will be available whenever there is a cooling demand. The cooling signal can be accessed through X1 terminal points 1 and 2. The inflow is connected with the connector marked "IN" and the outflow with the connector marked "OUT".

Connection of mains supply

Power is connected to the unit in accordance with the name plate. Please refer to the wiring diagrams. Important! All electrical connections must be made in accordance with the local regulations. The main supply cable can be fitted through the electrical panel under the touch panel, or through any of the four connection points on either the air outlet side and top of the unit.

NOTE

The unit does not have an integrated safety switch. In case a safety switch is required due to regulations, the safety switch must be added by the installer

Main power supply

All electrical connections must be made in accordance with the regulations of the local power supply company.

Adding chemicals

The following guidance values are applicable to swimming pools where chemicals are added:

Chemicals	ppm
Free chlorine content	1,0-2,0
Combined chlorine content	Max. 1/3 of free chlorine content
pH	7,2-7,6
Total alkalinity	80-150
Calcium hardness	250-450
Total dissolved solids	< 2000
Sulphates	< 360

Self-production of chlorine

The following guidance values are applicable to swimming pools with self-production of chlorine:

Chemicals	ppm
Salt (NaCl)	2700-3400
Total dissolved solids	< 5500
pH	7,2-7,6
Total alkalinity	80-150
Calcium hardness	250-450
Sulphates	< 360

Langelier Saturation index

It is advisable to use the Langelier Saturation index to ensure that the combination of the different water parameters is acceptable. Contact the manufacturer, if necessary.

Service guide

Introduction The dehumidifier is designed to require minimal attention in order to run without issues. All the necessary safety and control functions have been built in. The fan motor and the compressor have permanent lubrication and require no particular maintenance.

Monthly service Once a month, the inlet air filter should be inspected and if necessary cleaned. Please follow the following procedure to perform the monthly service on the filter:

Step	Action
1	Open the inspection door
2	Take out the filter frame and remove the filter
3	Clean the filter in luke-warm soapy water or, if only slightly soiled, with a vacuum-cleaner
4	Replace the filter in its frame, which can then be pushed back into the unit

NOTE

Drip tray and drain must be cleaned so the water can flow out without obstruction.

Annual service Once a year, the interior of the unit should be checked for cleanliness. A service timer can be configured through the menu. Please follow this procedure to perform the annual service:

Step	Action
1	Cut the power, open the inspection door and remove the front cover panel
2	If the unit is dirty, it may be cleaned with a vacuum cleaner Important: Especially the condenser, and the fan rotor in particular, should be thoroughly vacuum-cleaned
3	If the evaporator fins are badly soiled, they may be cleaned with a long haired soft brush or with lukewarm soapy water

Service on components

In most cases, the components are accessible for service after having removed the inspection door and the cover panels. Otherwise pull out the entire bridge/rail onto which the components are fixed.

Important: Only qualified service technicians may carry out service on the components. Service on components is done as follows:

Step	Action
1	Switch off the unit
2	Open the inspection door and remove the front cover panel
3	Remove the section in the middle with the control panel
4	Undo the screws along the bridge/rail
5	Pull out the bridge/rail. Important: If the bridge/rail has to be pulled entirely out of the unit, then the fan wires must also be disconnected.

NOTE

Shut down the dehumidifier immediately, if it is not functioning correctly!

Fault finding guide

Fault finding Use this table to localize and solve a possible problem or fault:

More help If you cannot find the reason for the fault, switch off the unit immediately in order to prevent further damage. Contact a service technician or a representative from the manufacturer.

Display text	Type	Fault	Unit behaviour	Possible cause	Fault finding	Solution(s)
No text	-	-	Unit not operating / non responsive	Power supply interrupted 12VDC power supply malfunction Controller malfunction	- Check fuses in main switch-board - Verify that supply voltage is present at input terminals - Verify 12VDC output from PSU	Replace / re-connect supply fuse(s) Replace 12VDC PSU Replace controller
No text	-	-	Display dark or white with no text or graphic Dehumidifier operating normally	Display malfunction	Restart controller	Replace controller
-	-	No fault	Excessive fan noise	Inlet/outlet clogged Excessive back pressure	Verify if filter is clogged Verify if inlet/outlet has been restrained Verify dampers are open (if installed) Verify back pressure is within specified limits	Unrestrict air inlet / outlet
Low Temp.	Info	No fault	Unit in standby	Ambient temperature at RH sensor is too low	- Check actual ambient temperature	Unit will restart when ambient temperature is within operating limits
High Temp				Ambient temperature at RH sensor is too high	- Read measured ambient temperature in 'live data' menu view	
C. Sensor E. Sensor RH Sensor	Alarm	Sensor failure	Sensor failure can result in irregular behavior, LP Error or HP Error	Sensor malfunction	Read sensor value in 'live data' view Verify temperature sensor resistance (ohm)* Verify sensor wire integrity	Replace sensor

Display text	Type	Fault	Unit behaviour	Possible cause	Fault finding	Solution(s)
LP Error	Alarm	LP Error	LP Error reoccurring persistently Unit will pause and restart continuously No or irregular noise coming from compressor Evaporator coil can build up a small amount of ice around expansion valve No or limited condensate being produced	HP switch trip Refrigeration circuit leak causing loss of refrigerant Compressor malfunction	Verify if HP switch has been tripped due to prior HP error - confirm compressor is running - confirm fan is running - confirm solenoid valve is closed (no hissing sound from valve) Compressor does not start at all: - Confirm contactor K1 is functional - Confirm there is voltage at compressor terminals. Compressor attempts to start but will not run (clicking/humming from compressor): - Confirm that compressor voltage is within +/- 10% of nominal supply voltage - Confirm run capacitor / hard start capacitor (if installed) is within specifications	Press HP switch reset button Repair refrigeration circuit Replace compressor Replace run capacitor / hard start capacitor (if installed) Replace compressor
				Thermostatic Expansion Valve (TEV) defective	Verify if TEV is visually damaged: Check for cracks and/or corrosion in TEV head / capillary tube / TEV sensor bulb NOTE: The TEV can malfunction even without externally visible damage	Replace TEV
			Unit seemingly functions normally with no apparent fault. Evaporator coil cold, condenser coil warm. Permanent or periodic LP Error	Defective temperature sensor for evaporator coil or condenser outlet tube. Sensor wire break Bad contact to evaporator coil / condenser outlet tube Bad connection to Controller Controller failure	Verify temperature sensor resistance (ohm)* Verify sensor wire integrity Verify if sensor is fixed to the tube Verify plug is connected to controller Verify 12VDC controller supply voltage	Replace sensor Re-fit sensor Clean plug / reconnect to Controller Replace controller

Display text	Type	Fault	Unit behaviour	Possible cause	Fault finding	Solution(s)
LP Error	Alarm	LP Error	No or limited condensate draining from dehumidifier LP Error can be periodically present	Low ambient temperature and/or humidity can result in limited condensation of water Solenoid valve leak	Confirm compressor is running Confirm fan is running Confirm solenoid valve is closed (no hissing sound from valve) Hissing from solenoid valve Voltage at solenoid valve coil when there is no ice on evaporator coil	Wait for room temperature/humidity to increase Exercise valve by means of external magnet or by applying 230VAC to valve coil Replace solenoid valve
HP Error	Alarm	HP Error	Periodic HP Error Unit seemingly operating normally, fault condition will disappear Persistent HP Error Unit blocked for restart	Precondition of refrigerant leak or TEV failure Fan failure Air inlet/outlet clogged Coil(s) clogged HP temperature sensor fault Condenser coil clogged	See above Restart unit Verify fan is working. If fan switches off for no apparent reason it can be caused by the internal overload protection Verify dampers are open (if installed) Verify if inlet and/or outlet are clogged/restrained Verify if coils are clogged Verify temperature sensor resistance (ohm)	See above Replace fan Unrestrict inlet/outlet Replace temperature sensor Clean condenser coil

*Measure the resistance between the two wires coming from the NTC temperature sensor. Resistance should be within the range from 190kΩ - 0,14kΩ corresponding to -50..98°C

Cooling diagram

Condensation dehumidifier principle diagram.

1	Compressor	6	Filter drier
2	HP pressostat	7	Thermostatic expansion valve
3	Water-cooled condenser	8	Evaporator
4	Air-cooled condenser	9	Solenoid valve
5	Receiver		

**Schematics
of cooling
diagram**

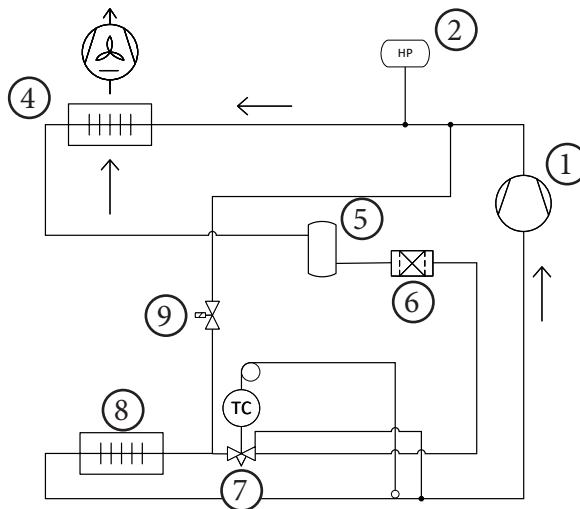

Condensation dehumidifier principle diagram with integrated water-cooled condenser.

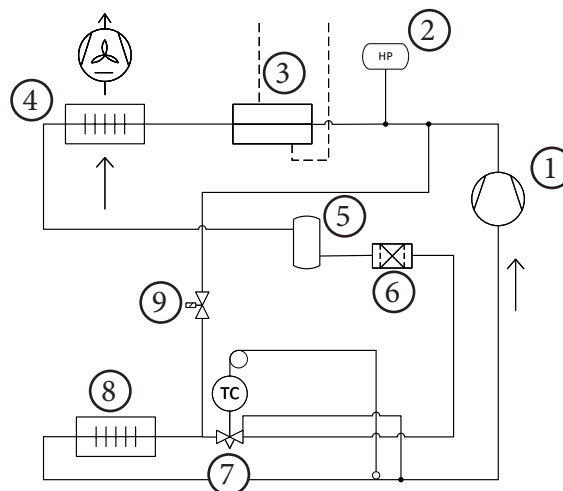
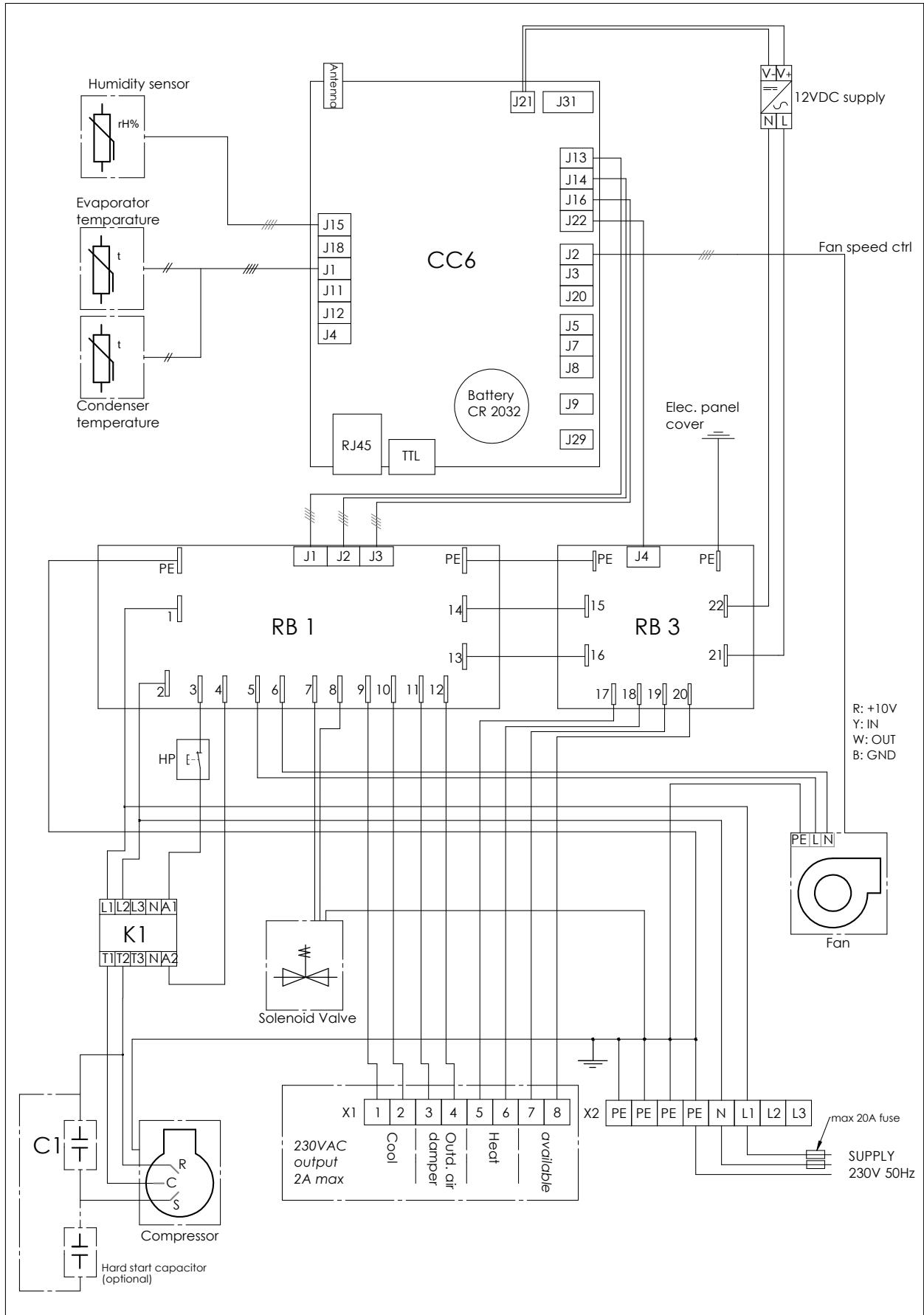
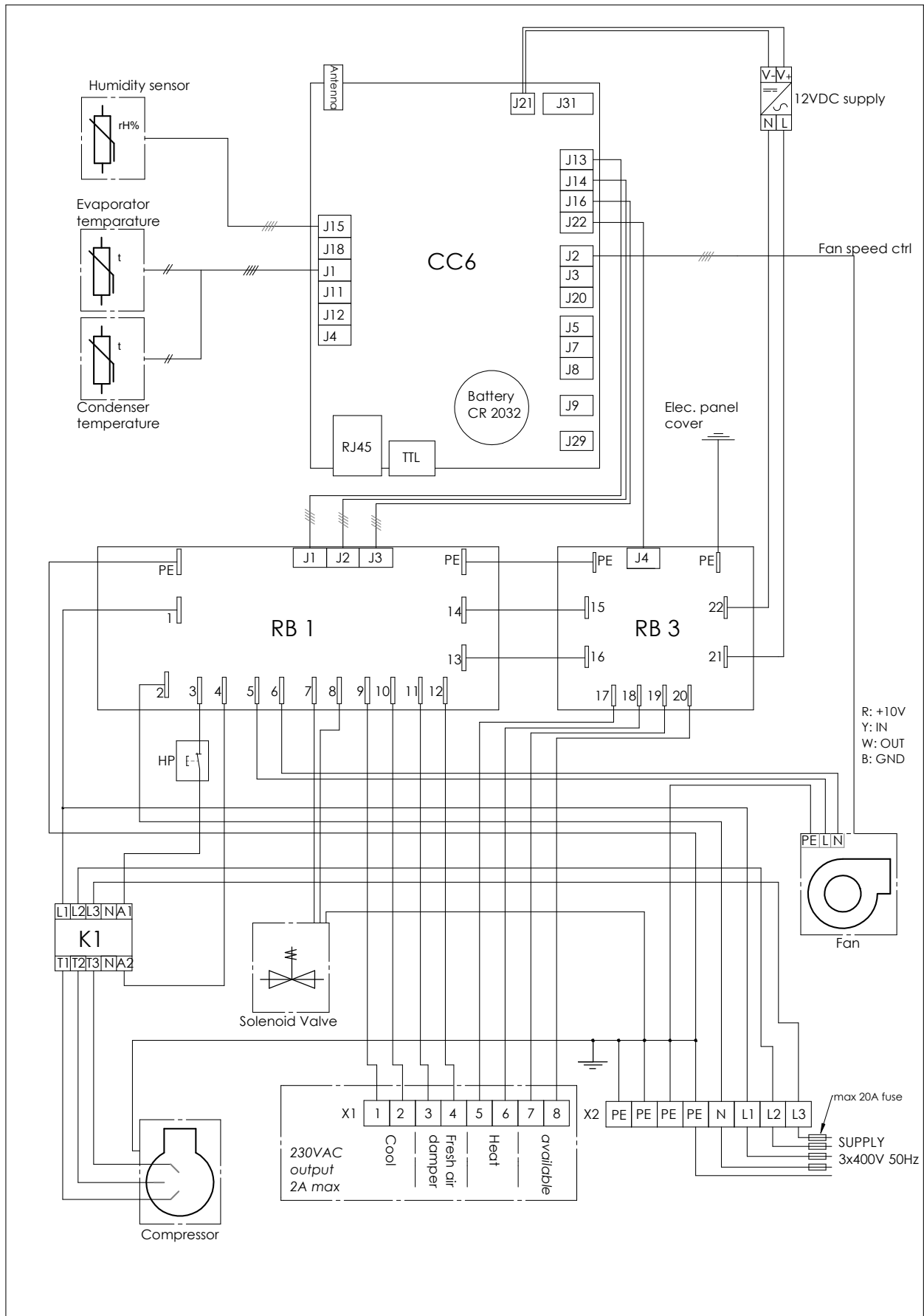

Fig. 7: Cooling diagram

Wiring diagram CDP 85-135, 230V



Wiring diagram CDP 135-175, 3x400V



Technical information

Technical data

Specification	Unit	CDP 85	CDP 135	CDP 175
Operational humidity range	% RH	40-100	40-100	40-100
Operational temperature range	°C	15-38	15-38	15-38
Air volume, nominal	m ³ /h	1500	2500	3600
Air volume, range	m ³ /h	500-1500	1200-2500	1500-3600
Dehumidification capacity***				
@ 20°C/60%	l/24h	56	75	N/A
@ 30°C/60%	l/24h	88	165	N/A
Max. external pressure loss ***	Pa	300	350	N/A
Power supply	V/Hz	1 × 230/50	1 × 230/50	-
		-	3 × 400/50	3 × 400/50
Max. power consumption	kW	2,0	3,6*/N/A**	6,0
Max. current	A	9,5	16,3* / N/A**	9,1
Locked Rotor Amps (LRA)	A	21	70*/25**	38
R454C gas weight/CO ₂ equivalent	kg/t	1,2 / 0,18	1,5 / 0,22	1,7 / 0,25
GWP (Global Warming Potential)	-	148		
Sound level @ 1 meter (nominal)	dB(A)	58	60	63
Weight	kg	130	160	190
Dimensions (w x d x h)	mm	1155x725x650	1300x900x850	1400x1010x975

*1x230V, **3x400V, ***Nominal air volume

Spare parts

This page contains the general information needed when ordering spare parts.

How to order

Spare parts can be ordered at <http://www.shop.dantherm.com>

When ordering, please specify the following:

- Spare parts number/text
 - Unit type
 - Production number and serial number from the nameplate of the unit (or approximate date of delivery).
-

Reservations

Not every item will be available individually if it is part of an assembly that forms a whole or if it is part of a complete component that has been purchased. The manufacturer reserves the right to make this assessment.

The manufacturer further reserves the right to make any necessary changes to the construction and selection of components without notice, but will, as far as possible, keep the changed parts in stock.

Disposal

General notes

Removal and disposal of the unit may only be performed by professionals.

All supply lines like electricity and hot water must be shut down before decommissioning and dismantling the equipment. Make sure that no water-glycol mixture is leaking.

Empty the refrigerant circuit for oil and refrigerant before dismantling.

Recycle all material according to national rules and procedures to protect the environment.

The controller contains a button cell battery. The battery must be removed before disposal. It is advisable to replace the battery after 5 years of use.



Batteries and accumulators are not to be disposed of with regular household waste. Directive 2006/66/EC OF THE EUROPEAN PARLIAMENT AND OF THE COUNCIL of 06 September 2006 on batteries and accumulators requires users to dispose the unit in a professional manner. Please dispose of batteries and accumulators in compliance with the applicable statutory provisions.



The symbol of the crossed-out waste bin on an old electrical or electronic appliance means that this appliance must not be disposed of in the household waste at the end of its service life. Collection points for old electrical or electronic appliances for free-of-charge return are provided to you locally. The addresses can be retrieved from your town or local administration. The separate collection of old electrical and electronic appliances is to enable the reuse, recycling and other forms of utilisation of old appliances and is to prevent negative impacts on the environment and human health when disposing of the hazardous substances potentially contained in the units.

Disassembly



DANGER

Risk of electric shock!

You can be severely injured by an electric shock.

- Disconnect the controller from the mains by unplugging the mains plug from the socket outlet before you open the controller!

CE - Declaration of Conformity CDP 85

Stationary Drying & Ventilation

Dantherm A/S
Marienlystvej 65
DK - 7800 Skive
Tel.: +45 96 14 37 00
Fax: +45 96 14 38 00

Declaration of following products:

Product name: **CDP 85**
Product no.: **351590**

The product is in conformity with the following directives:

2014/53/EU Radio Equipment Directive
2011/65/EU Restriction of the use of certain hazardous substances (RoHS) Directive

and is manufactured in conformity with the following standards:

EN 60335-1:2012 Household and similar electrical appliances – Safety – Part 1 (+AC:2014 + A11:2014 + A13:2017 + A1:2019 + A2:2019 + A14:2019+A15:2021)
EN 60335-2-40:2003 Household and similar electrical appliances – Safety – Part 2-40 (+A11:2004 + A12:2005 + A1:2006 + AC/2006 + A2:2009 +AC:2010 + A13:2012 + A13:2012/AC:2013)
EN 61000-3-2:2014 Electromagnetic compatibility (EMC) – Part 3-2
EN 61000-6-1:2007 Electromagnetic compatibility (EMC) – Part 6-1
EN 61000-6-3:2007 Electromagnetic compatibility (EMC) – Part 6-3 (+A1:2011 + A1:2011/AC:2012)
EN 50106:2008 Safety of household and similar electrical appliances – Particular rules for routine tests referring to appliances under the scope of EN 60335-1
EN 301 489-1 V1.9.2 Electromagnetic compatibility (EMC) standard for radio equipment and services; Part 1
EN 301 489-12 V3.2.1 ElectroMagnetic Compatibility (EMC) standard for radio equipment and services; Part 12
EN 300 220-2 V3.1.1 Short Range Devices (SRD) operating in the frequency range 25 MHz to 1 000 MHz; Part 2
EN IEC 63000:2018 Technical documentation for the assessment of electrical and electronic products with respect to the restriction of hazardous substances

Skive, May 06, 2024



Managing director Jakob Bonde Jessen

CE - Declaration of Conformity CDP 135, CDP 175

Stationary Drying & Ventilation

Dantherm A/S
Marienlystvej 65
DK - 7800 Skive
Tel.: +45 96 14 37 00
Fax: +45 96 14 38 00

en

Declaration of following products:

Product name: **CDP 135, CDP 175**
Product no.: **351591, 351592**

The product is in conformity with the following directives:

2014/53/EU	Radio Equipment Directive
2014/68/EU	Pressure Equipment Directive
2011/65/EU	Restriction of the use of certain hazardous substances (RoHS) Directive

and is manufactured in conformity with the following standards:

EN 60335-1:2012	Household and similar electrical appliances – Safety – Part 1 (+AC:2014 + A11:2014 + A13:2017 + A1:2019 + A2:2019 + A14:2019+A15:2021)
EN 60335-2-40:2003	Household and similar electrical appliances – Safety – Part 2-40 (+A11:2004 + A12:2005 + A1:2006 + AC/2006 + A2:2009 +AC:2010 + A13:2012 + A13:2012/AC:2013)
EN 378-2:2016	Refrigerating systems and heat pumps – Safety and environmental requirements – Part 2
EN 61000-3-2:2014	Electromagnetic compatibility (EMC) – Part 3-2
EN 61000-6-1:2007	Electromagnetic compatibility (EMC) – Part 6-1
EN 61000-6-3:2007	Electromagnetic compatibility (EMC) – Part 6-3 (+A1:2011 + A1:2011/AC:2012)
EN 50106:2008	Safety of household and similar electrical appliances – Particular rules for routine tests referring to appliances under the scope of EN 60335-1
EN 301 489-1 V1.9.2	Electromagnetic compatibility (EMC) standard for radio equipment and services; Part 1
EN 301 489-12 V3.2.1	ElectroMagnetic Compatibility (EMC) standard for radio equipment and services; Part 12
EN 300 220-2 V3.1.1	Short Range Devices (SRD) operating in the frequency range 25 MHz to 1 000 MHz; Part 2
EN IEC 63000:2018	Technical documentation for the assessment of electrical and electronic products with respect to the restriction of hazardous substances

Notified Body:

Force Certification
Park Allé 345
DK-2605 Brøndby

NOBO ID: 0200
NOBO Approval No: 15645-1

Skive, May 06, 2024

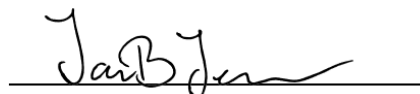

Managing director Jakob Bonde Jessen



Dantherm Denmark A/S

Marienlystvej 65

7800 Skive

Denmark

support.dantherm.com

Dantherm can accept no responsibility for possible errors and changes (en)

Der tages forbehold for trykfejl og ændringer (da)

Irrtümer und Änderungen vorbehalten (de)

Dantherm n'assume aucune responsabilité pour erreurs et modifications éventuelles (fr)

