

**NOTE:** 2'-0" [60 cm] ACCESS AROUND PERIMETER RECOMMENDED FOR SERVICE

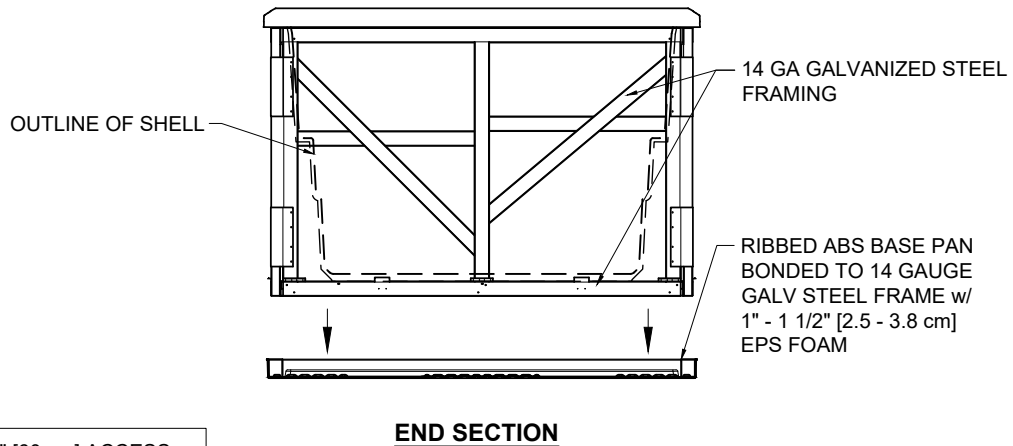

**E500 (58" Tall)**  
**Endless Pools® Fitness System**  
**General Information**  
AQUATIC FITNESS SYSTEMS DETAILS

DETAIL NUMBER:  
**WM-18.0.5**  
REV: 2019/01/09

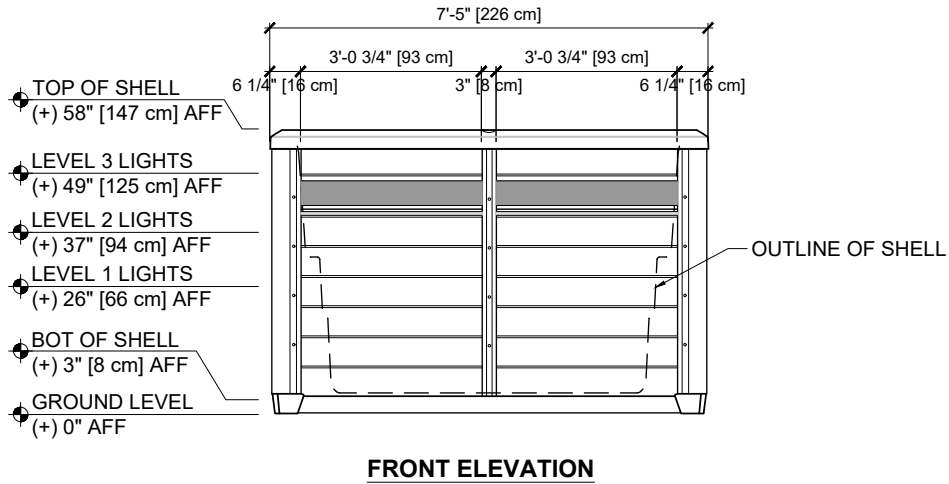
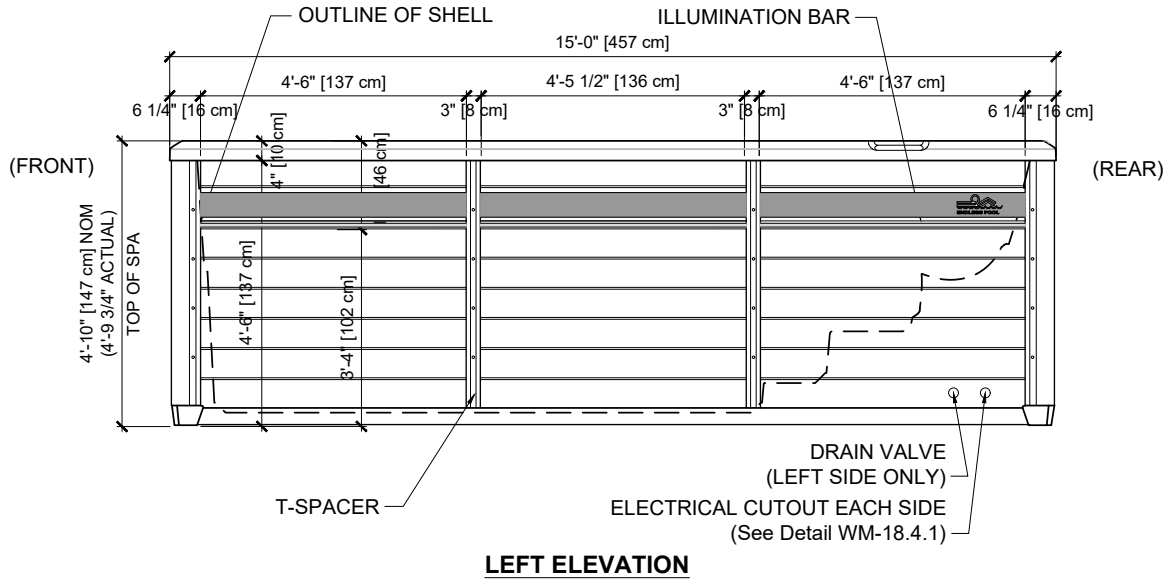

**NOTE:** 2'-0" [60 cm] ACCESS  
AROUND PERIMETER  
RECOMMENDED FOR SERVICE

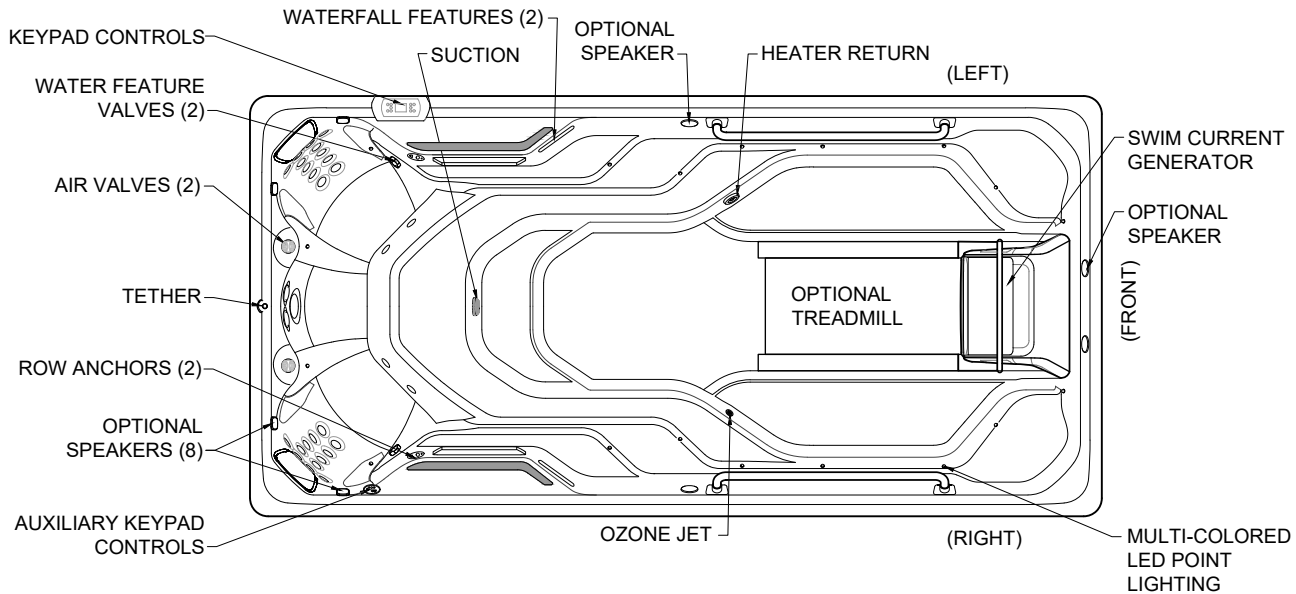

**SYSTEM PARTS**

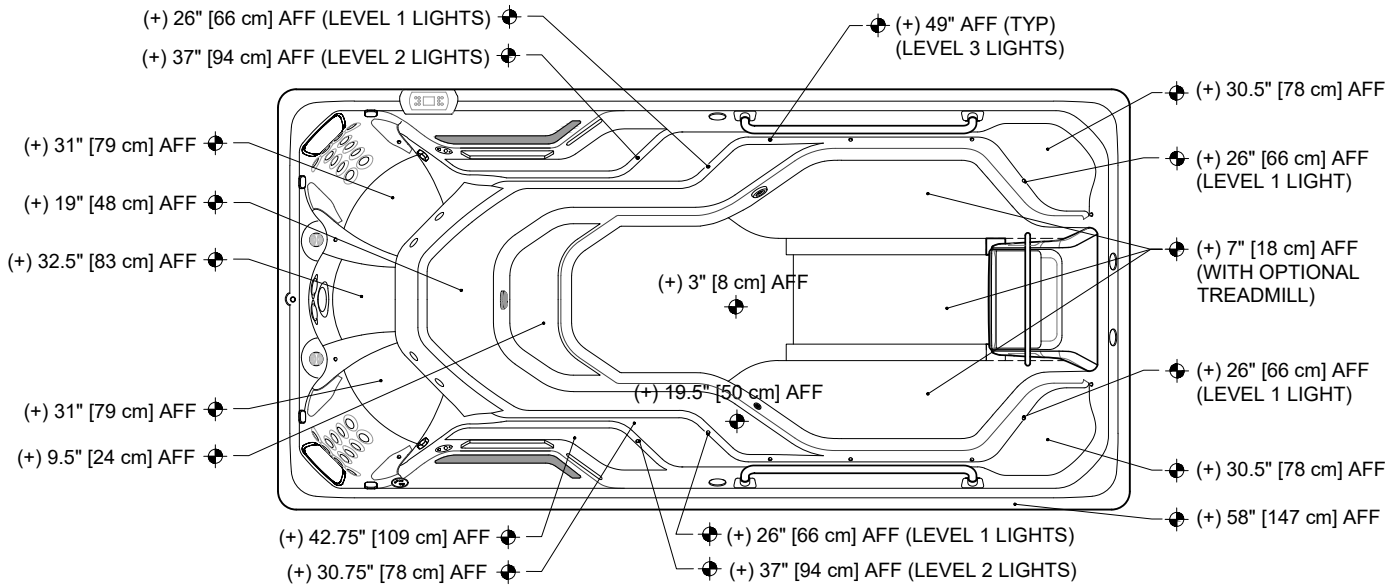

**SPOT ELEVATIONS**

(E500 SHOWN)



**E500 & E700 (58" Tall)**  
**Endless Pools® Fitness System**  
*Egress Details with Spot Elevations*  
AQUATIC FITNESS SYSTEMS DETAILS

DETAIL NUMBER:

**WM-18.2.3**

REV: 2019/01/04

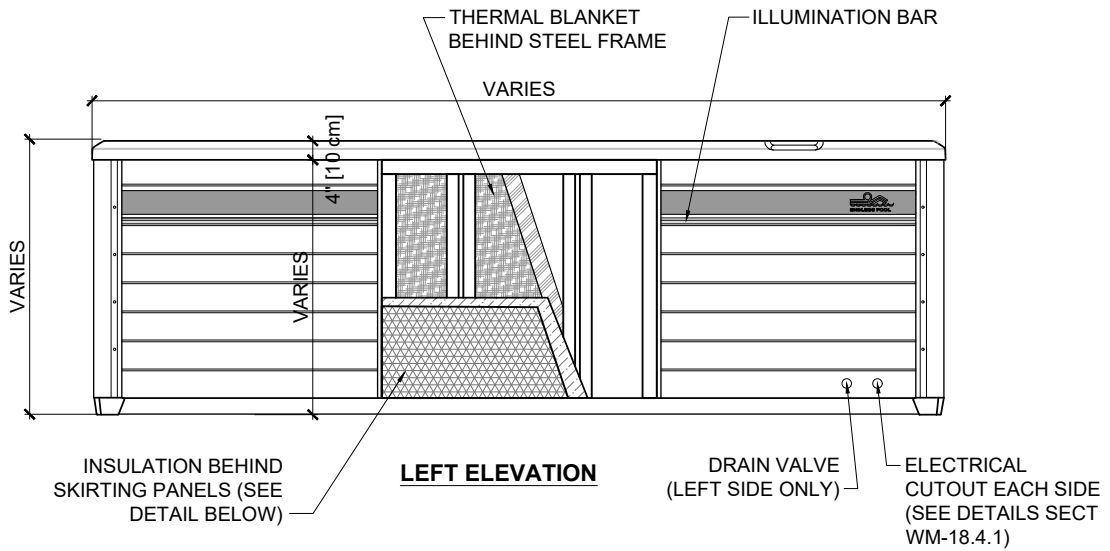

INSULATION BEHIND SKIRTING PANELS (SEE DETAIL BELOW)

**LEFT ELEVATION**

DRAIN VALVE (LEFT SIDE ONLY)  
ELECTRICAL CUTOUT EACH SIDE (SEE DETAILS SECT WM-18.4.1)

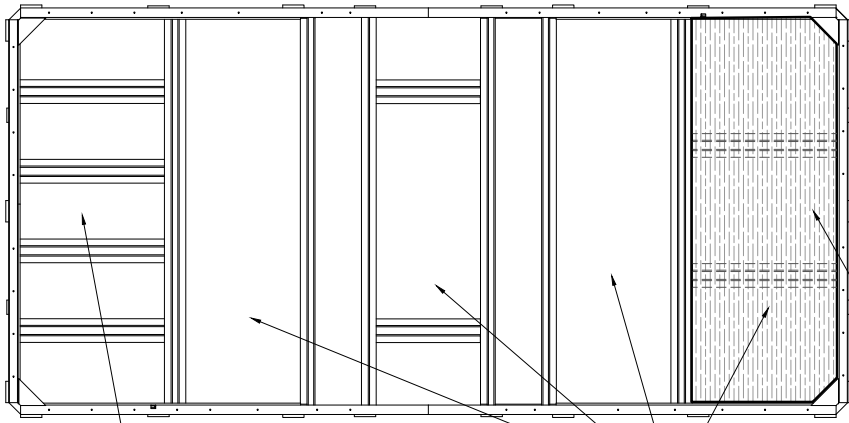

1" thick EPS FOAM INSULATION

**PLAN VIEW OF BASE**

1" thick EPS FOAM INSULATION

EQUIPMENT PLYWOOD SUPPORT OVER 1 1/2" thick EPS FOAM INSULATION

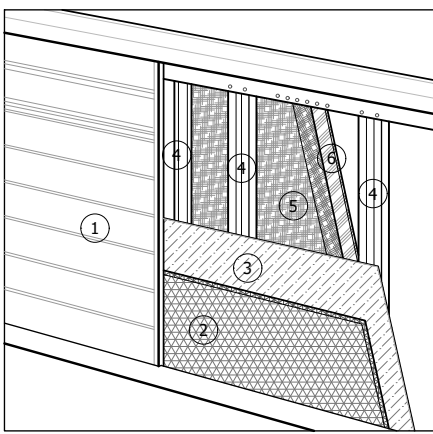
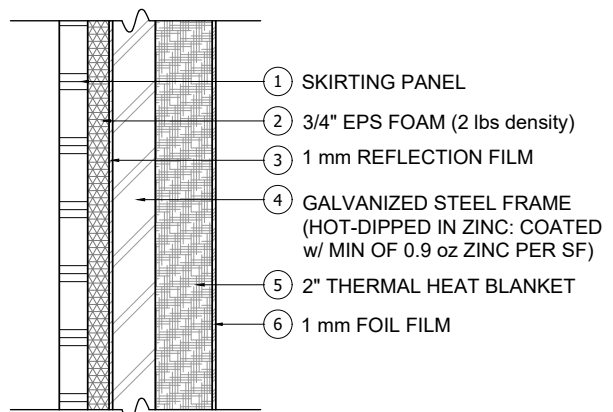

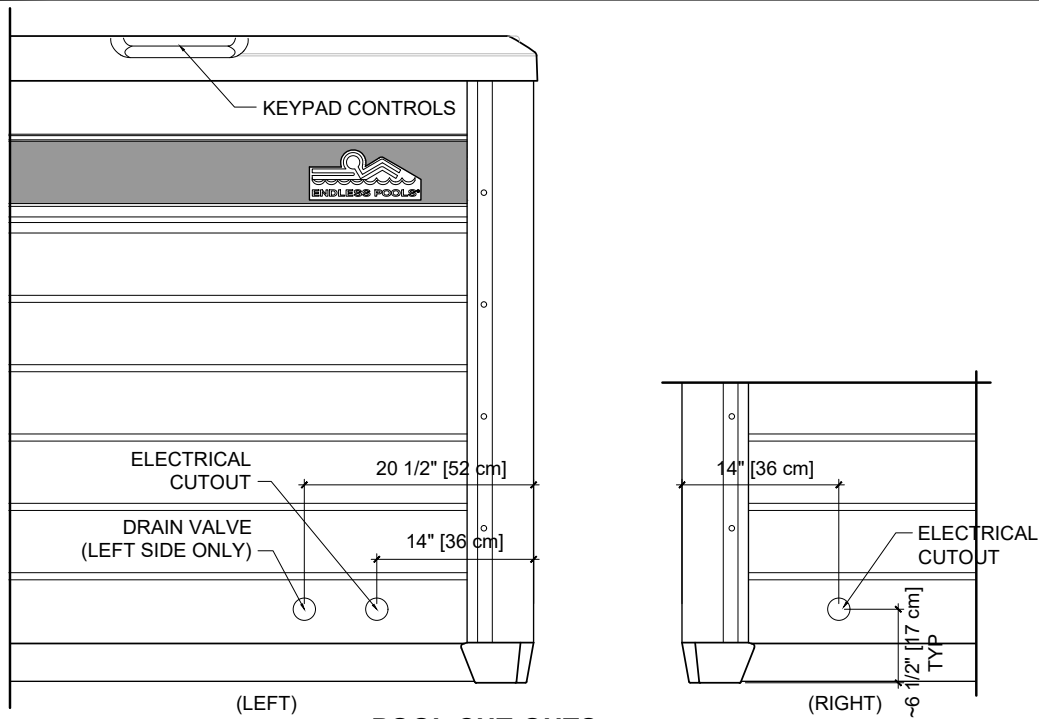

**POOL CUT-OUTS**

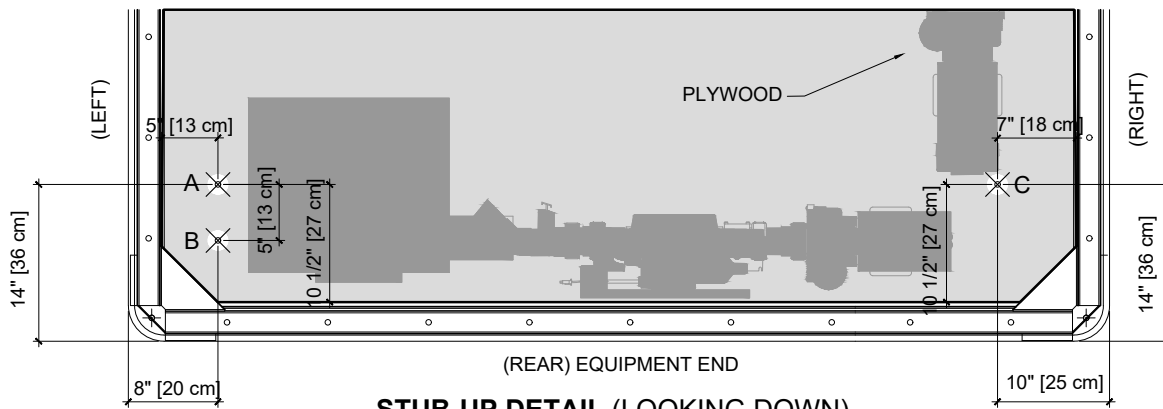

**STUB-UP DETAIL (LOOKING DOWN)**

**Stub-up Directions** (Use a 2" [5 cm] Hole Saw)

**Dimensions from Outside of Skirting:**

**Part 1:** (See Stub-up Detail). The stub-up will be located in the equipment end (rear) under the jetted seats. The center line for Stub-up 'A' can be measured at 8" [20 cm] from the skirting exterior on the left side of the Aquatic Fitness System (AFS) and 14" [36 cm] from the skirting at the rear.

If a 2nd hole is needed: (Stub-up 'B'). The dimensions are 8" [20 cm] from the skirting exterior on the left side and 9" [23 cm] from the skirting on the rear.

Alternately, if Stub-up 'C' is needed, centerline measured at 10" [25 cm] from the skirting exterior on the right side and 14" [36 cm] from the skirting on the rear.

**Dimensions from Inside of Cabinet:**

**Part 2:** When the AFS arrives: Remove the vertical T-spacer of the rear skirting by removing the four screws using a 5/16" socket. Slide panel towards center until panel is no longer behind corner. *Disconnect the wiring harness attached to panel before pulling out panel.* While holding panel, first slide panel up, then pull bottom away.

Once inside the AFS skirted cabinet, locate the black painted plywood base and measure from the edges of the plywood for the centerline: for Stub-up 'A': 5" [13 cm] from the left side and 10 1/2" [27 cm] from the end.

If a 2nd hole is needed: (Stub-up 'B'). Measure 5" [13 cm] from the left side and 5 1/2" [14 cm] from the end of the plywood base.

Alternately, if Stub-up 'C' is needed, centerline 7" [18 cm] from the right side and 10 1/2" [27 cm] from the end of the plywood base.



**Electrical Supply Location Options  
For E500 & E700**

AQUATIC FITNESS SYSTEMS DETAILS

DETAIL NUMBER:

**WM-18.4.1**

REV: 2019/01/15

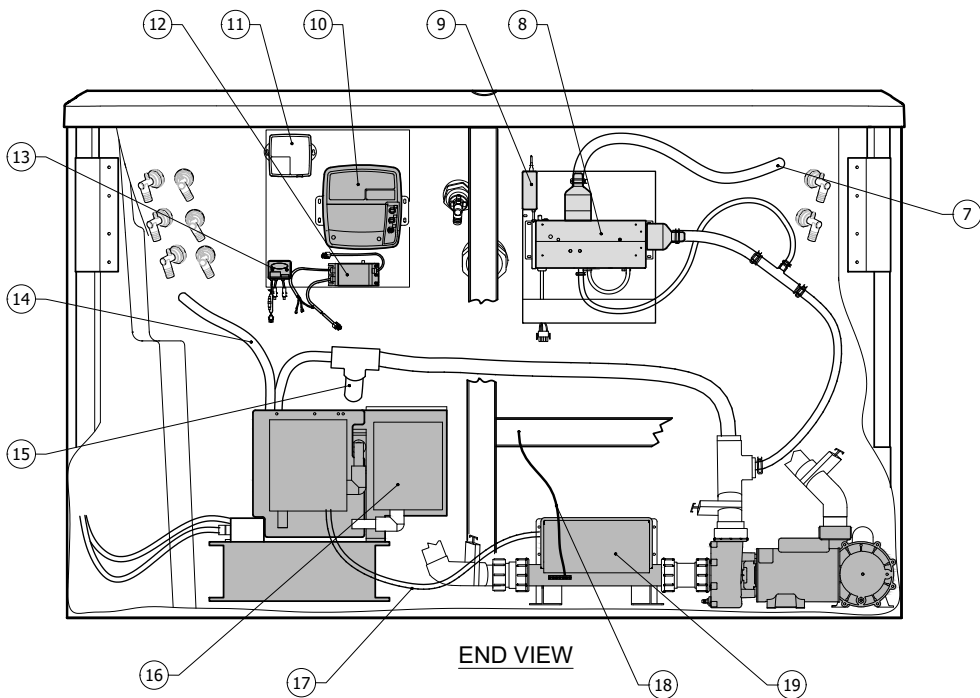
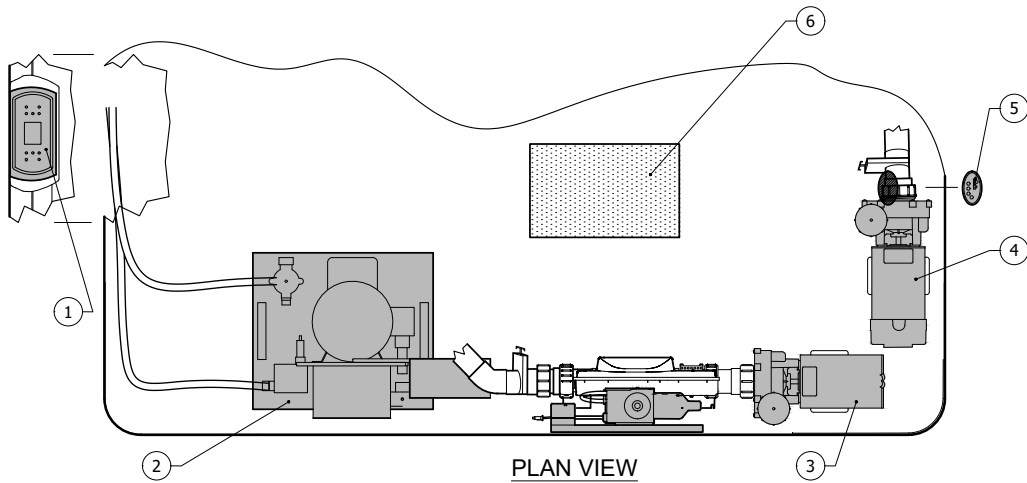

- |   |  |   |   |
|---|--|---|---|
| ① | KEYPAD CONTROLS                                    | ⑪ | OPTIONAL IN-TOUCH SYSTEM                        |
| ② | HYDRAULIC POWER UNIT<br>(IF TREADMILL, TANDEM HPU) | ⑫ | DUAL OUTPUT POWER SUPPLY<br>FOR EXTERNAL LIGHTS |
| ③ | CIRCULATION PUMP                                   | ⑬ | LIGHT CONTROLLER                                |
| ④ | HYDROMASSAGE JETS PUMP                             | ⑭ | WATER LINES                                     |
| ⑤ | AUXILIARY KEYPAD CONTROLS                          | ⑮ | TO HEATER RETURN                                |
| ⑥ | OPTIONAL AUDIO SUBWOOFER                           | ⑯ | JUNCTION BOX                                    |
| ⑦ | TO OZONE JET                                       | ⑰ | POWER WIRE WHIP                                 |
| ⑧ | UVC OZONE  | ⑱ | BONDING WIRE                                    |
| ⑨ | POWER SUPPLY TO UVC OZONE                          |   | CONTROLLER/HEATER                               |
| ⑩ | OPTIONAL AUDIO BLUETOOTH AMPLIFIER                 |   |   |

