

NOTE: 2'-0" [60 cm] ACCESS AROUND PERIMETER RECOMMENDED FOR SERVICE



X500
SwimCross™ Exercise System
General Information
AQUATIC FITNESS SYSTEMS DETAILS

DETAIL NUMBER:

WM-18.0.3

REV: 2019/01/09

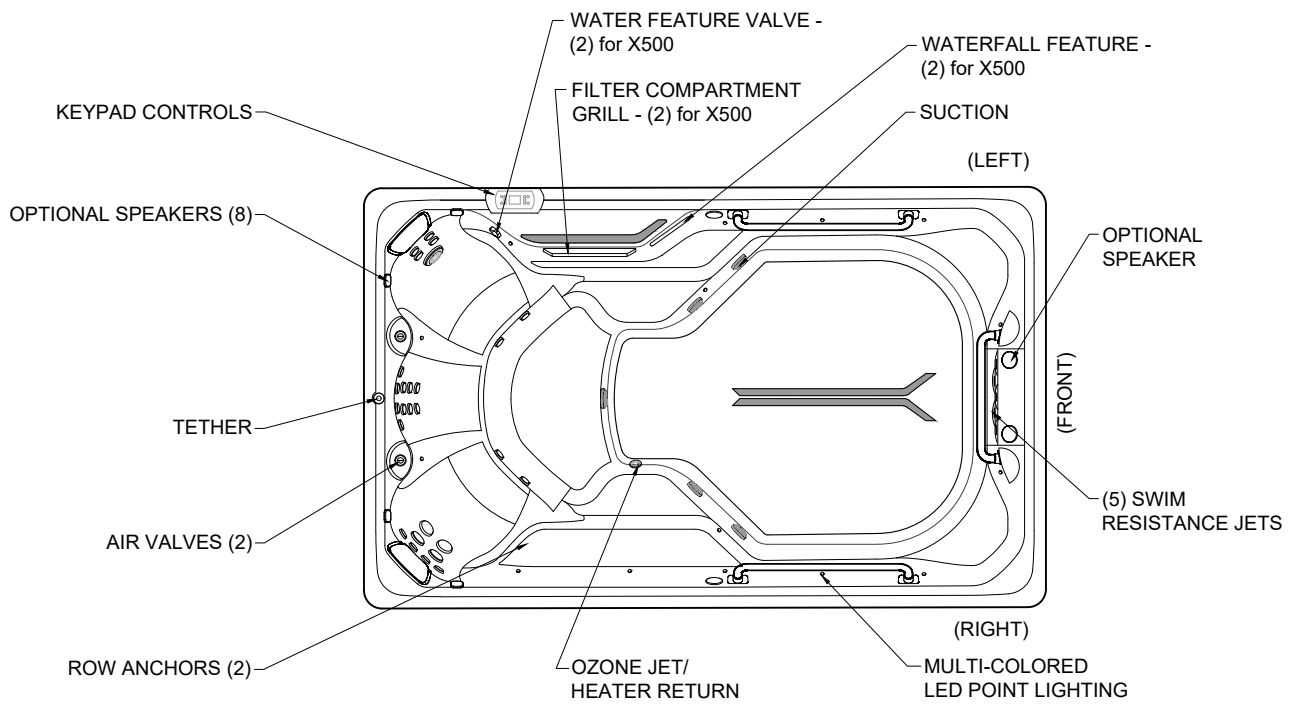

SYSTEM PARTS (X200 SHOWN)

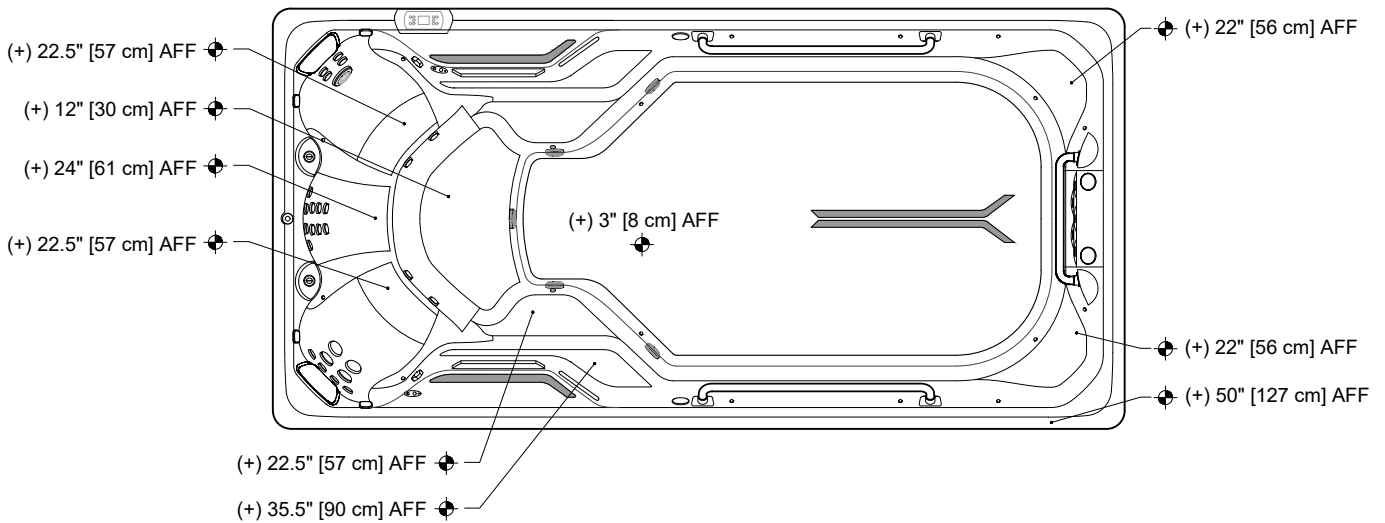

SPOT ELEVATIONS (X500 SHOWN)

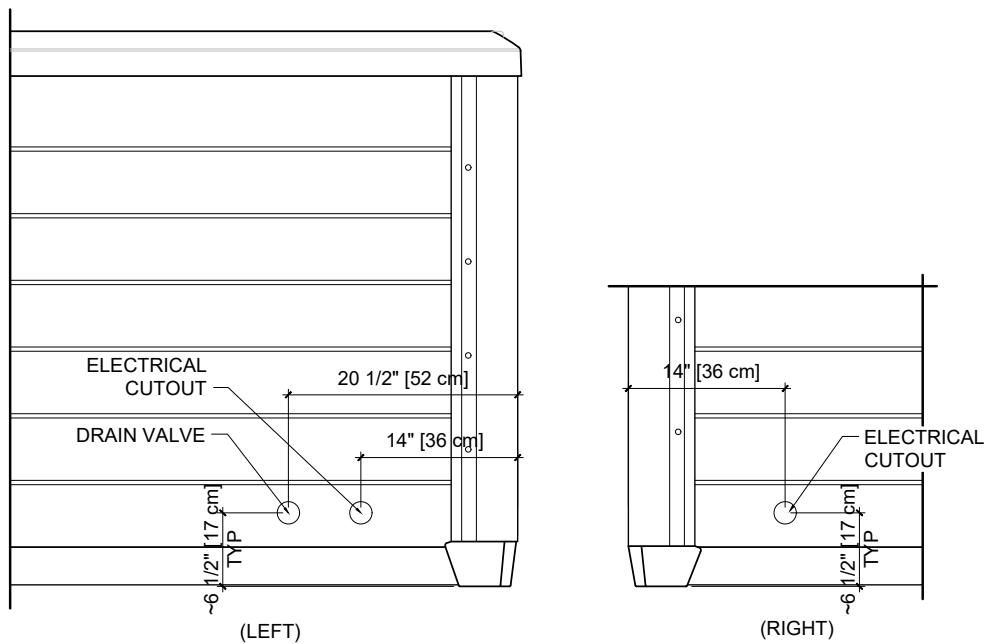

POOL CUT-OUTS

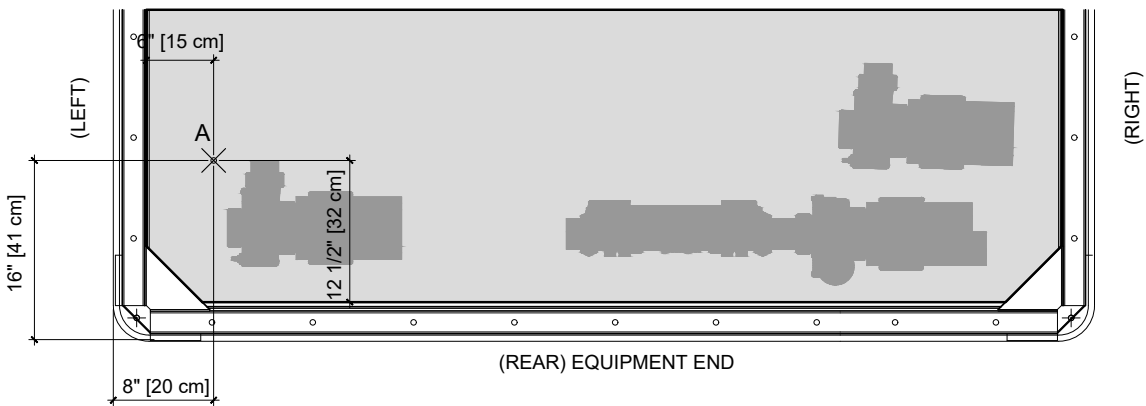

STUB-UP DETAIL (LOOKING DOWN)

Stub-up Directions (Use a 2" [5 cm] Hole Saw)

Dimensions from Outside of Skirting:

Part 1: (See Stub-up Detail). The stub-up will be located in the equipment end (rear) under the jetted seats. The center line for Stub-up 'A' can be measured at 8" [20 cm] from the skirting exterior on the left side of the Aquatic Fitness System (AFS) and 16" [41 cm] from the skirting at the rear.

Dimensions from Inside of Cabinet:

Part 2: When the AFS arrives: Remove the vertical T-spacer of the rear skirting by removing the four screws using a 5/16" socket. Slide panel towards center until panel is no longer behind corner. *Disconnect the wiring harness attached to panel before pulling out panel.* While holding panel, first slide panel up, then pull bottom away.

Once inside the AFS skirted cabinet, locate the black painted plywood base and measure from the edges of the plywood for the centerline: for Stub-up 'A': 6" [20 cm] from the left side and 12 1/2" [32 cm] from the end.



**Electrical Supply Location Options
For X200, X500, R120/R200 & R500**

AQUATIC FITNESS SYSTEMS DETAILS

DETAIL NUMBER:

WM-18.4.0

REV: 2019/01/15