

## Section 1: Parts List

### Swim Pace Display Kit

Swim Pace Display unit  
 14" of Velcro tape  
 50' of communication cable  
 Water-tight enclosure fitting

### Tools Required (supplied by others)

Staple gun  
 Hammer  
 Drift or punch

## Section 2: Description

The Digital Pace Display, which can be mounted indoors or outdoors, provides a useful indication of the speed of the swim current/treadmill in any Endless Pool product. The display will show the pace the current/treadmill is creating. A swim current configuration is the equivalent of swimming 100 yards (or 100 meters if set to metric) in the indicated amount of time. The hydraulic treadmill display will read as miles per hour (or kilometers per hour). Any Pace Display can be set for a percentage (2-100).

## Section 3: Planning Considerations

The Pace Display can be placed wherever it is convenient and visible to the swimmer. It is weather resistant, though reliability is enhanced if it is placed in a somewhat protected location free from frequent or heavy rainfall. The large, bright LED characters and non-glare face are well suited for use in direct sunlight, but visibility is improved when the unit is mounted in shade.

The display unit should be mounted near the pool where it is easily visible while swimming. The Velcro mounting tape allows you to attach the unit to virtually any surface.

The Pace Display gets its signal and power through a communication cable from the controller. Make sure your mounting location allows you to route the cable easily from the controller. A 50ft (15.2m) long cable is provided with the Pace Display. If a longer cable is required an extension kit, including a 50ft (15.2m) cable and coupler, can be supplied.

## Section 4: Installation Instructions



**WARNING!**

Disconnect power to the system before performing any maintenance involving electrical equipment.



**NOTICE**

Do not coil excess communication cable. This will create interference which will cause inaccurate readings on the display.



**NOTICE**

The communication cable and any connectors should be protected from the elements.

### Display Mounting

Attach one or two lengths of the “loop” portion of the Velcro tape to the back of the case of the display. Once you have selected an appropriate location, attach matching lengths of the “hook” side of the tape to the mounting surface. The Velcro will attach to most surfaces. If attaching to unfinished wood, it is advisable to staple the tape to the wood. Align the Pace Display and press in place.

**Wiring**

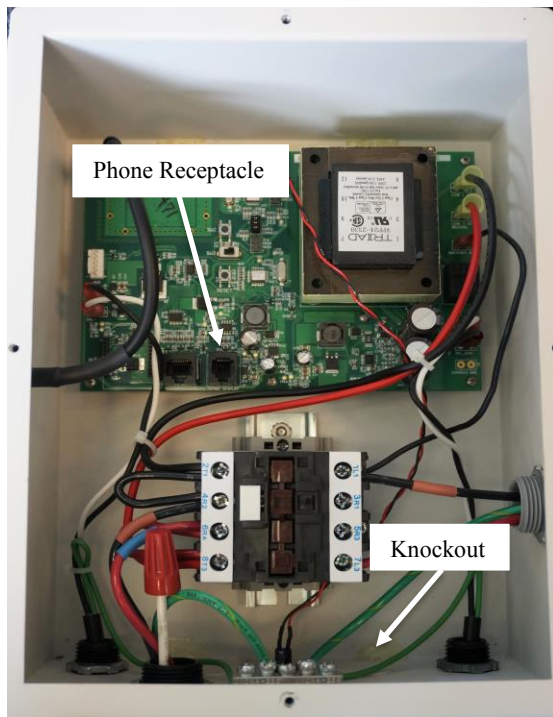

Clip the communication cable into the receptacle in the bottom of the display. Route the cable to the controller making sure it is well-secured and poses no hazards. A 50ft (15.2m) long cable is provided with the Pace Display. If a longer cable is required an extension kit, including a 50ft (15.2m) cable and coupler, can be supplied. All connectors and couplers must be protected from the elements. Run a continuous length of communication cable if possible. If couplers are used, they must be placed in junction boxes for protection.

The enclosure of the controller has a knockout in the bottom panel where the cable will pass through (A knockout is a partially-cut hole in the wall of the enclosure). Remove the knockout with a hammer and a punch. Install the water-tight fitting in the hole. Feed the cable through the water-tight fitting from the outside in.

Locate the green receiver board in the controller. Plug the cable into the right phone receptacle found on the green circuit board. Route the cable neatly inside the enclosure and tighten the water-tight fitting to seal and secure the cable. Provide power to the system. Once the propulsion unit is started, the display will light up and will default to displaying the speed of your swim current/treadmill as a percentage (2-100).

**Configuring**

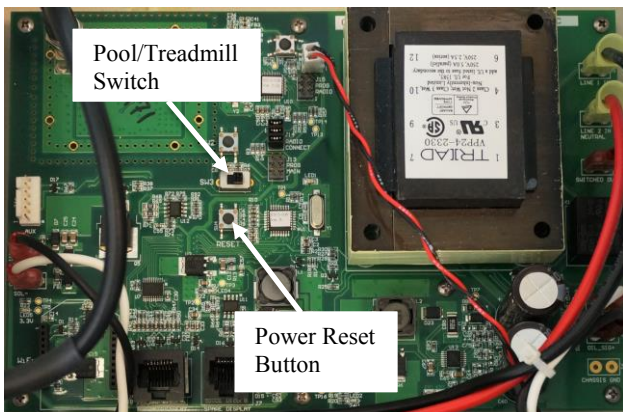

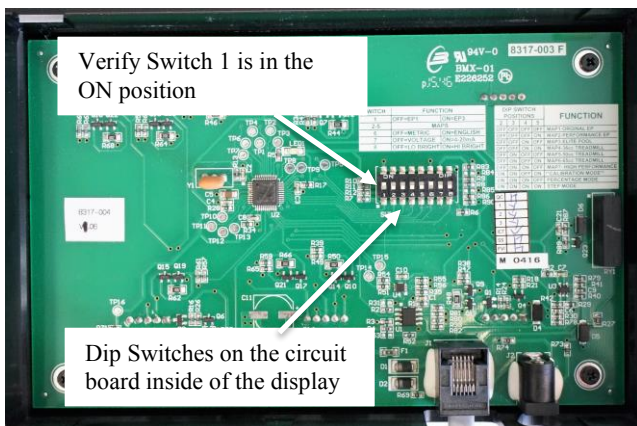

To set the display to show the speed of the swim current/treadmill in yards, meters, mph, or kmph, it needs to be configured to the appropriate setting. The first step is setting the Pool/Treadmill switch. If the Pace Display is being used in conjunction with the swim current, the Pool/Treadmill switch must be set *towards* the “SW3” on the circuit board. If the Pace Display is being used in conjunction with the treadmill, the Pool/Treadmill switch must be set *away* from the “SW3” on the circuit board.



Open the case of the display by grasping the front side of the case and carefully squeeze the top and bottom together at each end. This will disengage the latches holding the front and back together. Locate the 8 dip stitches on the circuit board. Verify that dip switch 1 is ON (in the up position). The rest of the switches can be disregarded.

**Accessing Settings Menu (Swim Current)**

1. If power has been supplied to the Hydraulic Power Unit for longer than 5 minutes, reset the breaker or press the “Power Reset” button on the circuit board and wait for the controller to restart.  will appear on the screen followed by the pace in percentage mode (2-100). Once the controller has fully restarted, the screen will go blank.
2. The blue remote will be used to navigate through the menu. The “Slower” button will act as a *DOWN* arrow while the “Faster” button will act as an *UP* arrow. The “On/Off” button will act as a selection button. Using the blue remote, press the combination UP, DOWN, UP, DOWN, UP, DOWN continuously until you see  on the pace display screen.

**Parameters of the main menu are as follows:**



The type of swim current



The unit of measurement displayed





Control Mode (How the swim current is being controlled)





Exiting the menu and confirming selected settings



The first parameter that must be set is the type of swim current. Once in the menu, the first parameter that will be displayed is . Press the On/Off button to access this parameter. Refer to Chart A on the next page for the appropriate setting. Setting this parameter ensures that the appropriate speed range is set for the swim current product that is present. If this setting is not correct, it could adversely effect the accuracy of the display as well as the speed range. Once the appropriate setting is displayed, press the On/Off button to confirm the setting.  will be displayed briefly before going back to the main menu.



The next parameter that must be set is the type of units that will be displayed on the screen when the swim current is running. Press the Slower button until  is displayed. Press the On/Off button to access this parameter. Refer to Chart B on page 5 for the appropriate setting. Once the desired setting is displayed, press the On/Off button to confirm the setting.  will be displayed briefly before going back to the main menu.



The next parameter that must be set is the Control Mode. Press the Slower button until **CEL** is displayed. Press the On/Off button to access this parameter. Mode **1** should be selected if the swim current is being controlled with the blue remote controls. Mode **2** should be selected if the swim current is being controlled by the Mobile App which is used in conjunction with the optional Wifi Kit. Once the appropriate setting is displayed, press the On/Off button to confirm the setting. **SEL** will be displayed briefly before going back to the main menu.



Press the Slower button until **Fin** is displayed. Press the On/Off button to exit the menu and confirm all settings. Once a pace is displayed, the unit is configured and ready to use.

Chart A

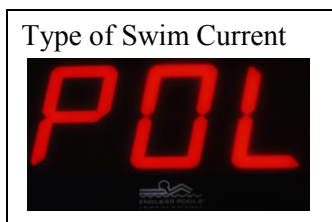

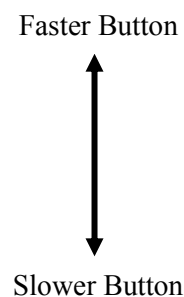

Percentage Mode (default)	
Original Endless Pool/Fastlane	
Performance Endless Pool	
High Performance Endless Pool	
Elite Endless Pool	
Escape Sub Menu	

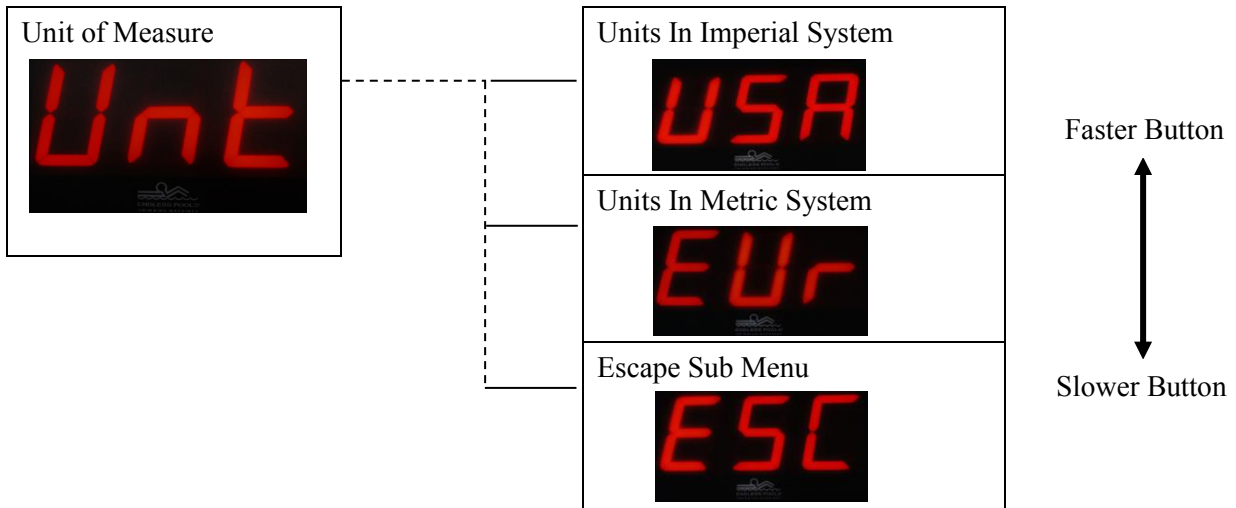

**Chart B**



**Accessing Settings Menu (Treadmill)**

1. If power has been supplied to the Hydraulic Power Unit for longer than 5 minutes, reset the breaker or press the “Power Reset” button on the circuit board and wait for the controller to restart.  will appear on the screen followed by the pace in percentage mode (2-100). Once the controller has fully restarted, the screen will go blank.
2. The blue remote will be used to navigate through the menu. The “Slower” button will act as a *DOWN* arrow while the “Faster” button will act as an *UP* arrow. The “On/Off” button will act as a selection button. Using the blue remote, press the combination UP, DOWN, UP, DOWN, UP, DOWN continuously until you see  on the pace display screen.

**Parameters of the main menu are as follows:**



The type of treadmill



The unit of measurement displayed



Control Mode (How the treadmill is being controlled)



Exiting the menu and confirming selected settings





The first parameter that must be set is the type of treadmill. Once in the menu, the first parameter that will be displayed is **POL**. Press the On/Off button to access this parameter. Refer to Chart C on page 8 for the appropriate setting. Setting this parameter ensures that the appropriate speed range is set for the treadmill that is present. If the treadmill appears as Figure 1 (Chain Drive/Belt Drive Treadmill), then choose **ecd**. If the treadmill appears as Figure 2 (Direct Drive Treadmill), then refer to the packing list (of the original treadmill purchase) to determine the correct hydraulic motor size. The majority of direct drive treadmills are equipped with 50cc motors. If unsure of the motor size, please contact Endless Pools Customer Service for assistance. If this setting is not correct, it could adversely effect the accuracy of the display as well as the speed range. Once the appropriate setting is displayed, press the On/Off button to confirm the setting. **SEE** will be displayed briefly before going back to the main menu.

**Figure 1:** Chain Drive/Belt Drive Treadmill

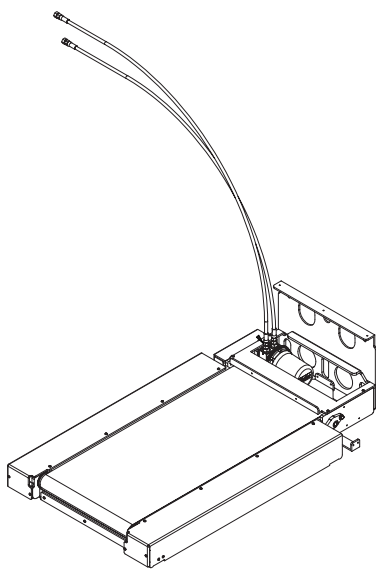

**Figure 2:** Direct Drive Treadmill

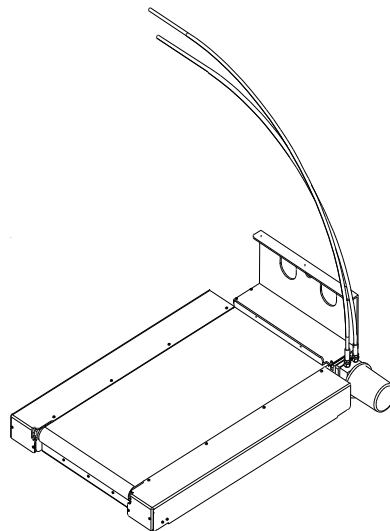



The next parameter that must be set is the type of units that will be displayed on the screen when the treadmill is running. Press the Slower button until **Unit** is displayed. Press the On/Off button to access this parameter. Refer to Chart D on page 8 for the appropriate setting. Once the desired setting is displayed, press the On/Off button to confirm the setting. **SEL** will be displayed briefly before going back to the main menu.



The next parameter that must be set is the Control Mode. Press the Slower button until **CEL** is displayed. Press the On/Off button to access this parameter. Mode **1** should be selected if the treadmill is being controlled by the blue remote controls. Mode **2** should be selected if the treadmill is being controlled by the Mobile App which is used in conjunction with the optional Wifi Kit. Once the appropriate setting is displayed, press the On/Off button to confirm the setting. **SEL** will be displayed briefly before going back to the main menu.



Press the Slower button until **Fin** is displayed. Press the On/Off button to exit the menu and confirm all settings. Once a pace is displayed, the unit is configured and ready to use.

**Chart C**

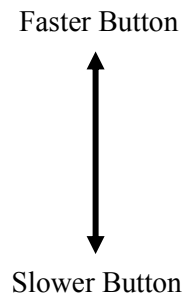
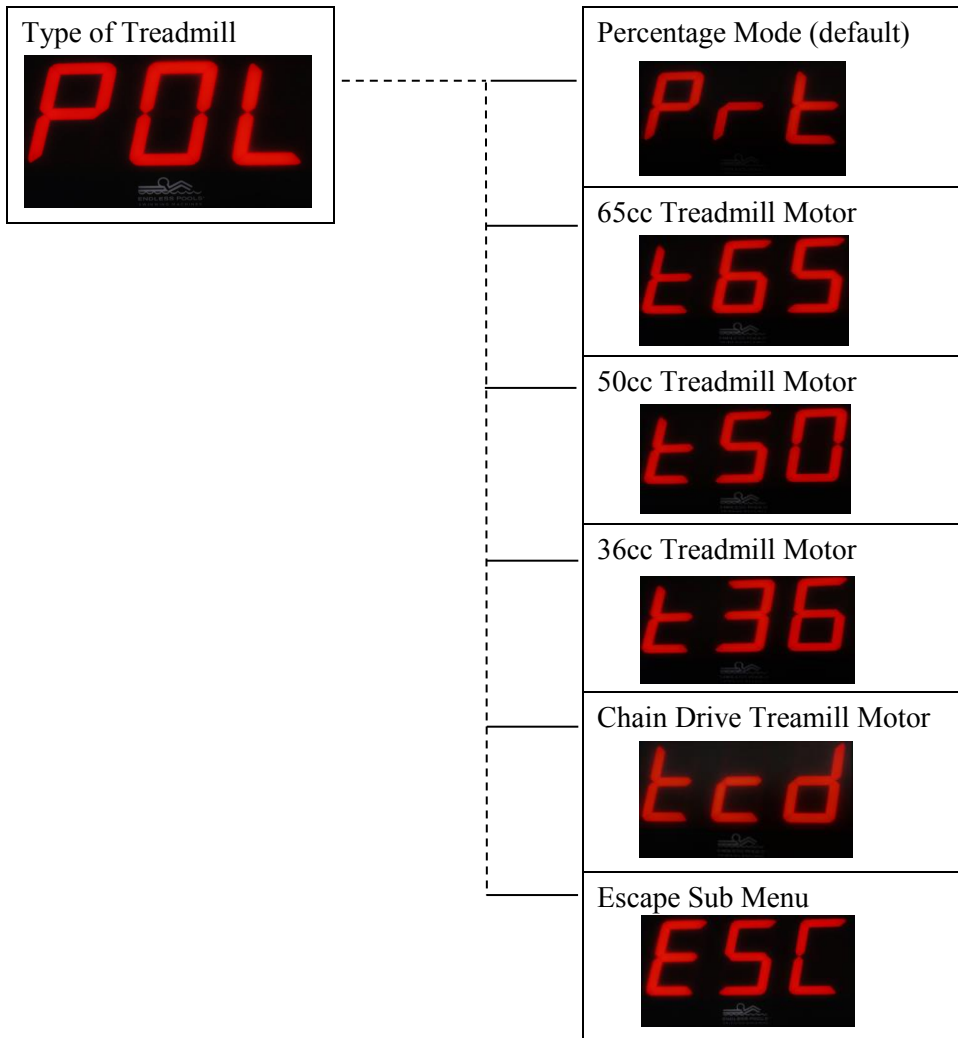

**Chart D**

