

PENTAIR

La Sta-Rite, La Sta-Rite VS2

The industry standard and classic Pentair Pump for compact pools

High efficiency – Low maintenance – Reliability



Sta-Rite



Sta-Rite VS2



Sta-Rite VS2

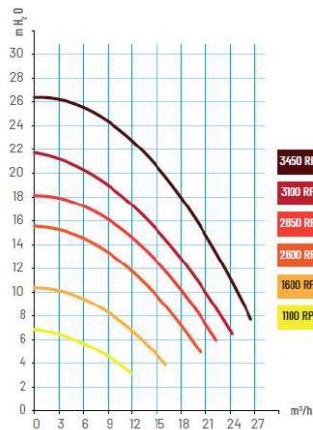

Sta-Rite

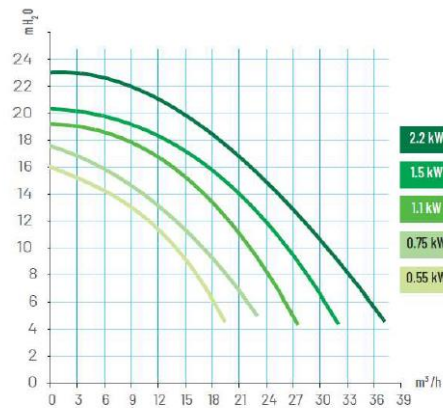

FEATURES - BENEFITS

Stainless steel locking clamp - Quick maintenance and upgradability into variable speed pump

Removable pre filter - Possibility to transform the pump into booster pump

XL pre filter basket - Longer periods between cleanings

TECHNICAL FEATURES

Inlet / Outlet 1.5" BSP

Ø Unions 50 mm Int.

Unions included yes

Salt resistancy 0,4 %

VARIABLE SPEED VS2

- Oversized 3hp asynchronous motor derated to 1.5hp to deliver high efficiency even at high speed
- 3 programmable speed/tim + override
- Simple and intuitive LCD display with Watts, RPM and time info
- Real time clock with 24hrs retention
- 4 digital inputs for external control (optional communication cable - PN. 353129Z)

TECHNICAL SPECIFICATIONS

Part Number	Speed	m ³ /h @ 8m	Power Output		Power supply		Length (mm)	weight (kg)	Warranty (years)
			(cv)	(kW)	Volt (V)	Phase			
P-STR-051	Single	8	0,5	0,37	220-240V	Single	514	14,1	3
P-STR-053	Single	8	0,5	0,37	380-420 V	Three	514	13,9	3
P-STR-071	Single	12	0,75	0,55	220-240V	Single	514	14,1	3
P-STR-073	Single	12	0,75	0,55	380-420 V	Three	514	14	3
P-STR-101	Single	16	1	0,75	220-240V	Single	514	15,8	3
P-STR-103E3	Single	16	1	0,75	380-420 V	Three	514	25	3
P-STR-151	Single	20	1,5	1,1	220-240V	Single	544	17	3
P-STR-153E3	Single	20	1,5	1,1	380-420 V	Three	544	26	3
P-STR-VS2	Variable		1,5	1,1	220-240V	Single	560	22,6	3+1

DIMENSIONS

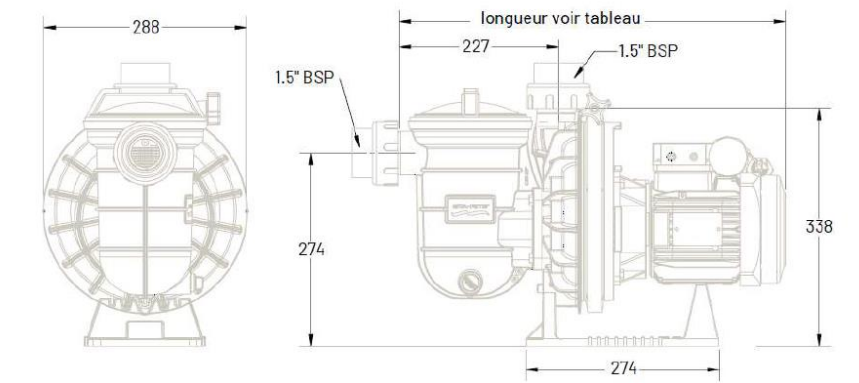

Part Number	BOX			PALET			
	Length (mm)	Width (mm)	Height (mm)	Length (mm)	Width (mm)	Height (mm)	pc/palet
La Sta-Rite	642	318	363	120	100	150	18
La Sta-Rite VS2	787	367	433	120	80	150	9