



V-PAC inverter heat pumps

VPT 12, 16, 22

Owner Installation Manual 1005759 Issue 3



HEALTH AND SAFETY WARNING

This product contains electrical and rotational equipment. **ONLY** competent trained people should work on this device, and must be isolated electrically before removing access panels.

This appliance can be used by children from 8 years and above and persons with reduced physical, sensory or mental capabilities or lack of experience and knowledge if they have been given supervision or instruction concerning use of the appliance in a safe way and understand the hazards involved. Children should not play with the appliance. Cleaning and user maintenance shall not be made by children without supervision.

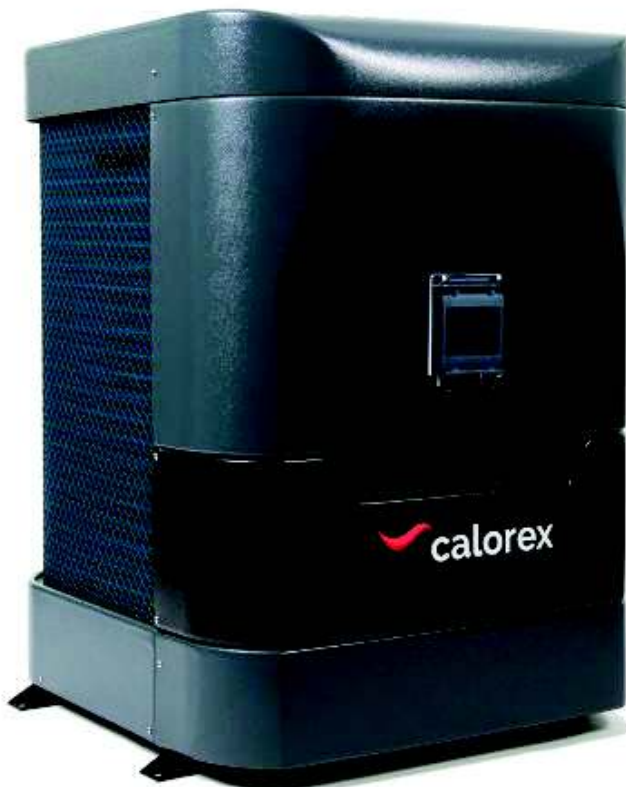

CONTENTS

HEALTH AND SAFETY WARNING	2	4.0 USING YOUR HEAT PUMP	19
1.0 INTRODUCTION	4	4.1 THE KEY PAD	19
1.1 FOREWORD	4	4.2 OPERATING INSTRUCTIONS	20
1.2 WARNINGS	4	5.0 TESTING	22
2.0 ABOUT YOUR HEAT PUMP	8	5.1 HEAT PUMP MALFUNCTION	23
2.1 TRANSPORTATION	8	5.2 PROTECTION CODES	24
2.2 ACCESSORIES.....	8	5.3 FAULT CODES.....	25
2.3 FEATURES.....	9	6.0 MAINTENANCE	26
2.4 OPERATING CONDITIONS AND RANGE	9	7.0 TROUBLE SHOOTING COMMON FAULTS	26
2.5 OPERATING MODES	9	8.0 DATA SHEET	27
3.0 INSTALLATION	10	9.0 DIMENSIONS	28
3.1 POSITIONING AND AIRFLOW	10	10.0 WINTERISATION PROCEDURE	29
3.2 REFRIGERANT TYPE AND INSTALLED LOCATION.....	13	10.1 START UP PROCEDURE AFTER WINTERISATION	29
3.3 POOL WATER CIRCUIT.....	14	11.0 WARRANTY CONDITIONS.....	30
3.4 PLUMBING.....	15	12.0 DECLARATION OF CONFORMITY	31
3.5 INITIAL CHECKS	15		
3.6 ELECTROLYTIC CORROSION IN SWIMMING POOLS.....	16		
3.7 ELECTRIC WIRING AND SUPPLY	16		
3.8 CONNECTING THE HEAT PUMP TO THE POWER SUPPLY	17		
3.9 POOL PUMP OVERRIDE TERMINALS P1/P2.....	18		

1.0 INTRODUCTION

1.1 FOREWORD

Thank you for choosing this product, which is designed for quiet and energy efficient operation. It is the ideal way to heat your pool in an environmentally friendly way.

This guide provides information needed to install and operate the product effectively. Please ensure you read this manual and use the correct installation and operating procedures.

This manual is intended for installers and users. Read the entire manual before using the heat pump. Awareness of the correct operating procedure for the machine and any safety devices is important, to avoid damage or injury.

The appliance can be used by children aged from 8 years and above and persons with reduced, physical, sensory or mental capabilities or lack of experience and knowledge if they have been given supervision or instruction concerning use of the appliance in a safe way and understand the hazards involved. Children shall not play with the appliance. Cleaning and user maintenance shall not be made by children without supervision.

1.2 WARNINGS

Important safety information is contained in this manual and marked on the heat pump.

Please read and follow all safety advice.

The refrigerant used in this heat pump is R32. This refrigerant is environmentally friendly, but safety instructions must be strictly adhered to.



R32 Gas

The WARNING sign denotes a hazard. It calls attention to a procedure or practice, which if not adhered to could result in injury. Warning signs and procedures must be complied with.

If a refrigerant leak is suspected stop using the heat pump and contact Dantherm Group UK service.

service.department@dantherm.com

Take the following precautions in order to avoid any danger:

REFRIGERANT SAFETY:

This heat pump contains R32 refrigerant. Work on the refrigeration system, repair and disposal must be carried out by appropriately qualified and registered engineers.

Repair, service and disposal must be carried out in the EU by F-Gas registered engineers.

Completely de-gas the refrigerant before any brazing is performed. Brazing can only be carried out by technicians trained to EU 517/2014.

Risk assessments must be carried out before maintenance or repairs are started.

Appropriate safety measures and risk assessments must be taken before work commences.

Do not attempt to work on the equipment by yourself.

Consult the qualified engineer undertaking the work to establish all requirements before work commences.

ACTIONS TO AVOID (OPERATION AND HANDLING):

Be especially careful when handling the heat pump, not to cause any damage that may result in leakage of the cooling circuit.

Do not use means to accelerate the defrosting process or to clean, other than those recommended by the manufacturer.

Do not pierce or burn.

IN CASE OF FIRE:

Toxic fumes may occur in the event of fire. You must leave the room as quickly as possible in the event of fire.

LOCATION REQUIREMENTS:

The heat pump contains R32 refrigerant so the following location requirements must be fulfilled:

The heat pump must be kept away from sources of fire or naked flames.

The heat pump must be installed, operated and stored where the floor area is larger than the minimum requirement, see section 3.2.

The heat pump shall be stored in a room without continuously operating ignition sources (for example: open flames, an operating gas appliance or an operating electric heater).

Keep the ventilation openings clear of obstruction during operation.

Do not use or store combustible gas or liquids near the heat pump.

Check if there are any local regulations, which you must comply to, when installing or storing the heat pump.

Be aware that refrigerants may not contain an odour.

Installation must be carried out by competent people, in accordance with this manual.

INSTALLATION:

Read the instructions before installation, use and maintenance.

If R32 gas leaks during the installation process, stop the installation immediately and call the service centre.

If a repair is required, please contact the nearest after-sales service centre.

To avoid over heating or over cooling of pool water check and set the temperature on the control panel.

The heating performance can be improved by insulating the flow and return pipework.

It is recommended that a cover is used on the swimming pool to reduce heat losses.

AIRFLOW:

The heat pump must have access to adequate airflow. See section 3.1.

Do not place obstructions that will block air flow near the inlet or outlet.

ELECTRICAL SAFETY:

Mains power isolator should be out of reach of children.

After a power cut, when the power supply is restored, the heat pump may start up without warning.

Electric storms can damage electronic equipment. Ideally the heat pump should be switched off at the mains.

HEAT PUMP MALFUNCTION:

WARNING: Isolate heat pump electrically and wait 3 minutes before removing panels or entering heat pump.

Refer to the user check list in section 6.2 and the error codes listed in section 6.3 before initiating a service call.

Do not attempt to interfere with any internal control settings as these have been factory calibrated and sealed.

Any sign of abnormal operation such as water dripping should be reported immediately to the installer. If in doubt or if advice is required contact the Service support team on telephone +44(0)1621 856611 (option 4).

MAINTENANCE:

Isolate the power supply of the heat pump and wait 3 minutes before cleaning examination or repair.





Please clean this machine with household detergents or clean water. NEVER use petroleum spirit, thinners or any similar fuel.

Check bolts, cables and connections regularly.

DISPOSAL:

Repair, service and disposal of redundant heat pumps must be completed by authorised technicians. It is illegal to allow refrigerant gases to escape to air.

Do not attempt to work on the equipment by yourself. Improper operation may cause danger.

 <p>R32 Gas</p>	<p>Do not use means to accelerate the defrosting process or to clean, other than those recommended by the manufacturer.</p>		<p>The heat pump must be kept away from sources of fire or naked flames.</p>
	<p>The appliance shall be stored in a room without continuously operating ignition sources (for example: open flames, an operating gas appliance or an operating electric heater).</p>		<p>The heat pump must be installed in well ventilated area. Closed areas are not permitted.</p>
	<p>Do not pierce or burn.</p>		<p>Repair and disposal must be carried out by F-Gas registered engineers.</p>
	<p>Be aware that refrigerants may not contain an odour.</p>		<p>Completely de-gas the refrigerant before any brazing is performed. Brazing can only be carried out by technicians trained to EU 517/2014.</p>
	<p>Appliance shall be installed, operated and stored in a room with a floor area larger than Xm^2, where X is the "minimum area" shown in section 3.2 and section 8.0.</p>		

2.0 ABOUT YOUR HEAT PUMP

2.1 TRANSPORTATION

Always keep the heat pump upright.

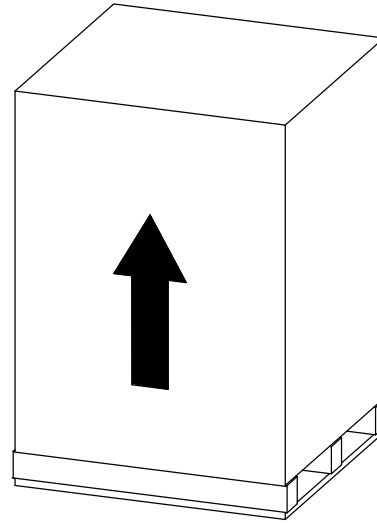

Do not lift the heat pump by the water inlet or outlet connections.

(If this is done the titanium heat exchanger inside the heat pump could be damaged).

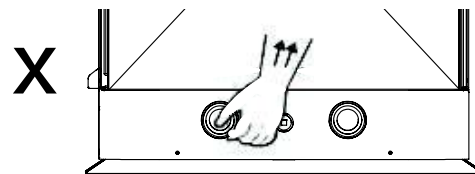

2.2 ACCESSORIES

These accessories are provided with the heat pump.

Water union connectors:

2 x 1 ½, 2 x 50mm

Drainage kit

4 x rubber mounts



2.3 FEATURES

- Stepless DC inverter compressor
- EEV Technology (Electronic Equalisation Valve)
- Quick hot gas defrosting with 4-way valve
- High-efficiency twisted titanium heat exchanger
- High pressure and low pressure protection
- Soft start and wide voltage application
- Stable inverter control system



2.4 OPERATING CONDITIONS AND RANGE

Air temperature operating range:
V-PAC (VPT X models): -5-43°C.

Water temperature setting range:
Heating: 18°C-40°C
Cooling: 12°C-30°C

2.5 OPERATING MODES

The heat pump has three modes: Powerful mode, Silent mode, and Smart mode.

Mode	Modes	Characteristics
	Powerful mode	Heating Capacity 100% Fastest heating, ideal for initial pool heat up.
	Silent mode	Heating Capacity 50% Quiet operation, ideal for night time operation.
	Smart mode	Heating capacity from 25% to 100% Intelligent optimization ideal for day to day operation.

3.0 INSTALLATION

Installation must only be attempted by competent personnel.

3.1 POSITIONING AND AIRFLOW



The heat pump must be positioned in a well ventilated area. Minimum distances between the heat pump and any obstructions are shown below.

- The heat pump must be fixed by M10 bolts to a concrete base or mounting brackets. These must be solid and fixed securely. Brackets must be corrosion proof.
- Do not block inlet or outlet grilles.

Airflow - general principles

The heat pump absorbs energy from the air drawn through it. To function effectively the heat pump must have access to the fresh air it needs.

- Air must not recirculate. The air leaving the heat pump must not be sucked back into the inlet.
- Air must not be restricted. The air volume must not be reduced.
- The minimum required distances shown below must be provided to minimise the risk of air recirculation or restriction and reduction in performance. Further examples are shown on the following page.

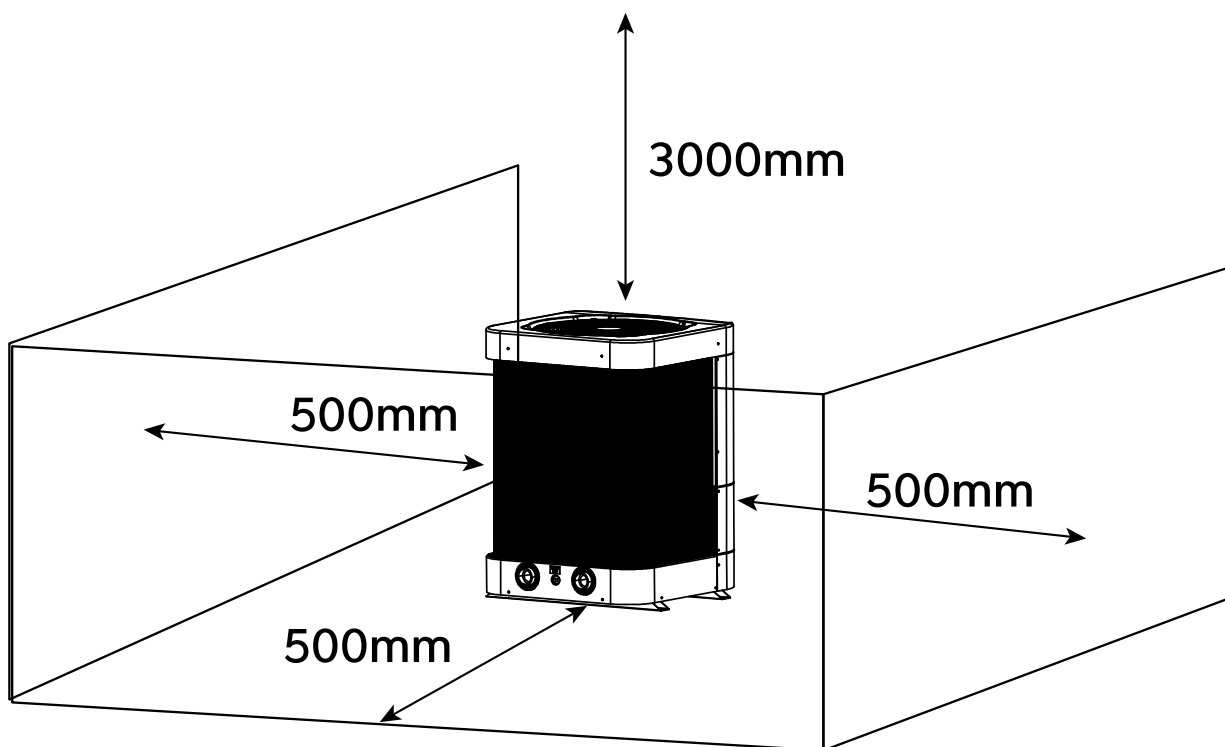

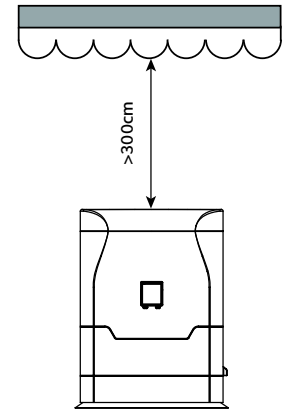
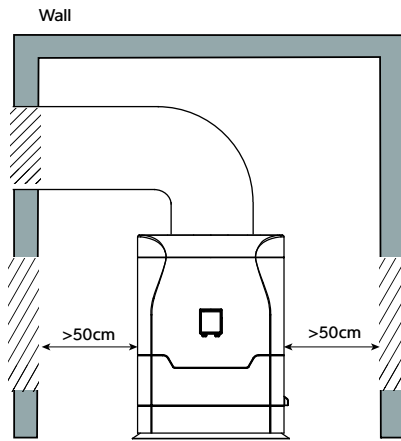
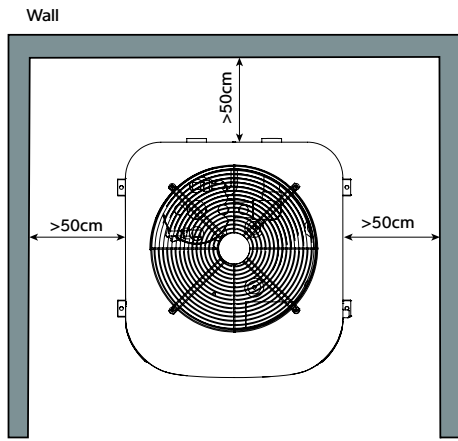

Typical inside or plant room installation.
(Not recommended for long duct runs).

The plant room must not be used as an occupied space.

Typical outside installation.

Required free areas to provide air flow to and from heat pumps when installed in an enclosed area or where required to pass air through a wall etc. Ensure holes through walls are sealed to avoid the outlet air entering cavities and to avoid the possibility of recirculation.

Free area is the available area through which air can pass through a grille or louvres.

Minimum free areas m ²	
Model	Discharge area
VPT 12	0.188
VPT 16	0.188
VPT 22	0.220

OWNER/INSTALLATION MANUAL

To comply with safety regulations regarding electrical installations in wet areas the heat pump must be installed at least 350cm away from the edge of the pool or spa.

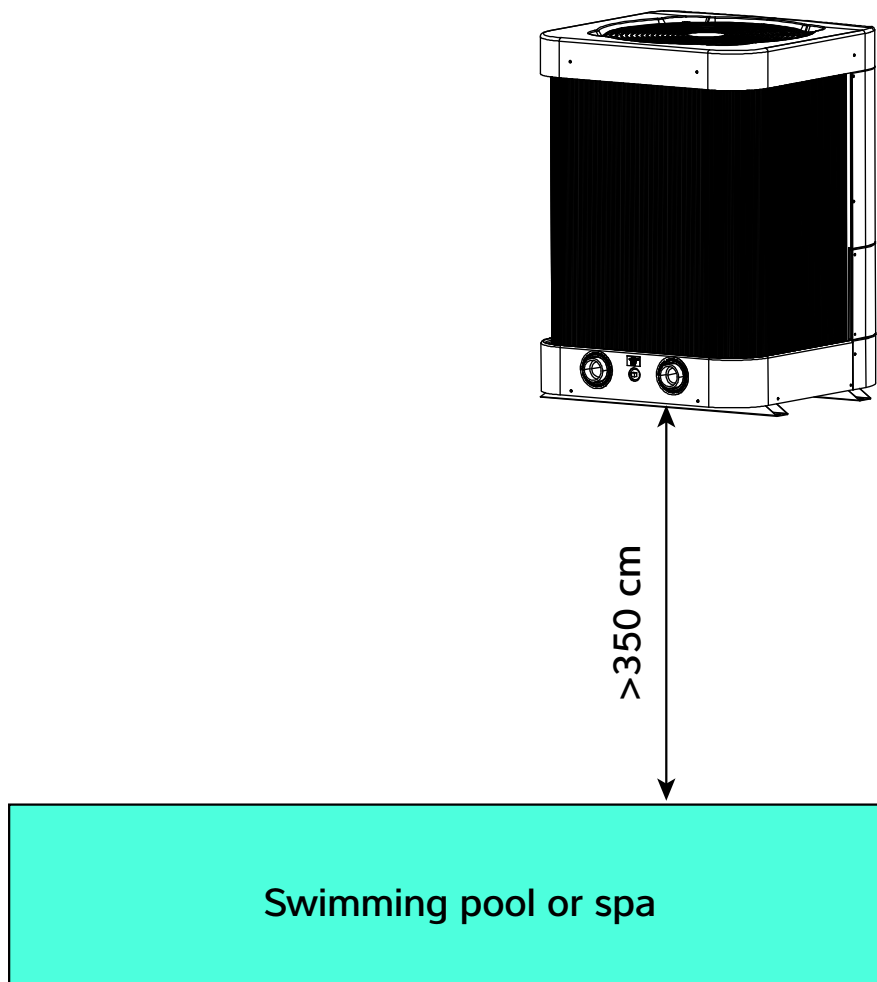

3.2 REFRIGERANT TYPE AND INSTALLED LOCATION

This heat pump contains R32, which is an environmentally friendly refrigerant with a GWP (Global Warming Potential) of 675. R32 has the safety in use classification of A2L, being low toxicity and lower flammability. In practical terms it is very difficult to ignite an A2L refrigerant, but this classification requires a risk assessment to be undertaken for the possibility of refrigerant being released by accident into an area connected to the heat pump, considering the application, location of components, and the installed refrigerant charge. This installation guidance can form the framework for such a risk assessment for the installation.

All flammable refrigerants will not ignite if the concentration level in a room stays below their lower flammability limit (LFL). European standard EN378 defines requirements to remain far below the lower flammable limit in case of accidental leakage. By choosing the location as dictated by EN378-1:2016 the probability of forming a flammable atmosphere can be eliminated. Please refer to the minimum area for each product and the interpretation below regarding locations of heat pump and swimming pool. This information is provided as a guide only and does not supersede the regulations or health and safety requirements.

Model		VPT12ALX	VPT16ALX	VPT22ALX
Refrigerant charge	R32 kg	0.8	0.8	1.7
Minimum area	m ²	5.4	5.4	24.6
Notes	*Assumed worst case for access category: a - general access and location class: I - mechanical equipment in occupied space; both as defined in line with EN378-1 2016 section 5.1 table 4 and section 5.3 *Minimum Area is calculated in line with section C.2 on EN378-1 2016 (calculation C.2).			

INTERPRETATION

Please refer to the installation situations below for how to apply the minimum area stated above.

Pool outside and heat pump outside:

Automatically meets the minimum area requirement because outside space is unlimited.

Pool outside and heat pump inside a plant room:

Automatically meets the minimum area requirement because the room must open to the outside for heat pump airflow and the outside space is unlimited.

Pool inside and heat pump outside:

The pool hall must exceed the minimum area requirement shown above.

Pool inside and heat pump inside a plant room, isolated from the pool hall:

The pool hall must exceed the minimum area requirement shown above.

Pool inside and heat pump inside a plant room, ventilated to the pool hall:

The pool hall and plant room combined must exceed the minimum area requirement shown above.

3.3 POOL WATER CIRCUIT

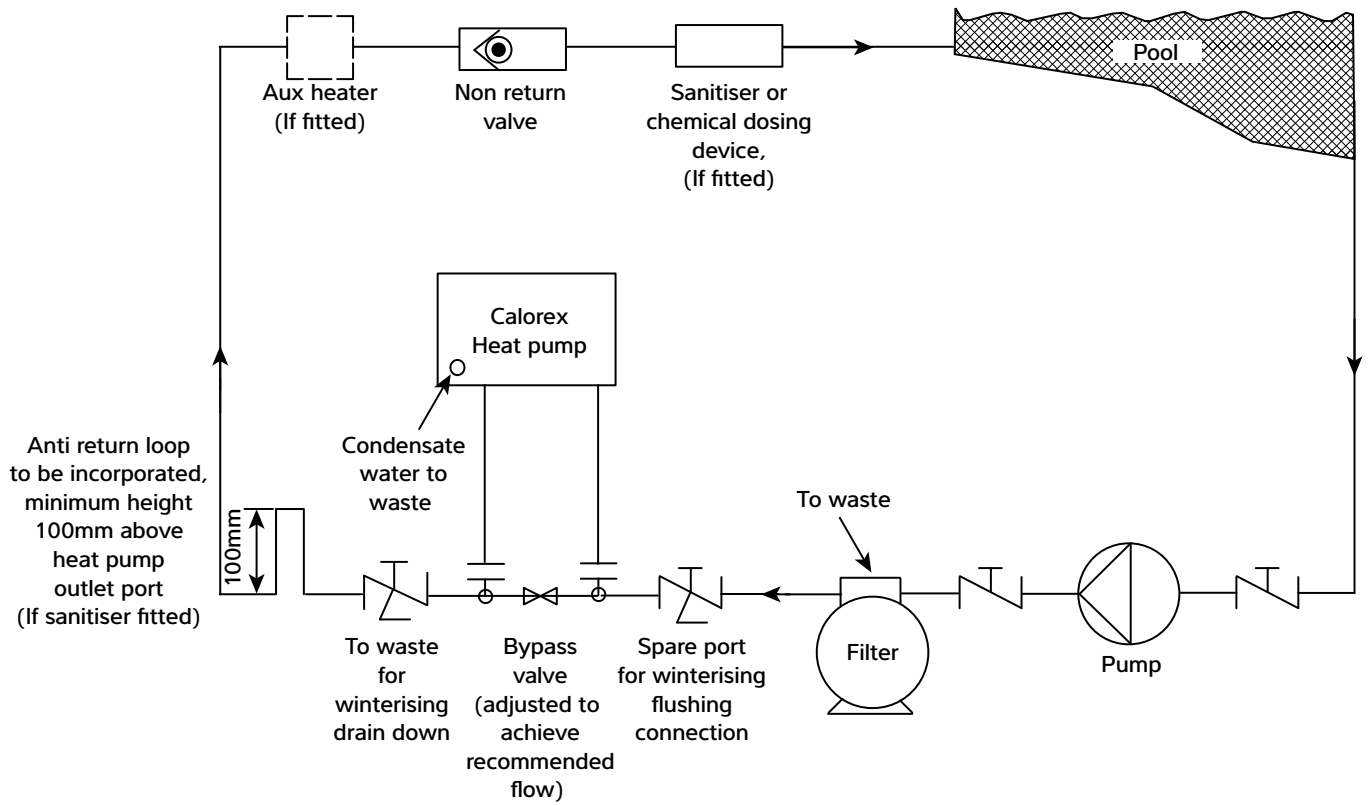

KEY	
Isolation valve	
Breakable coupling	
Three way valve	

3.4 PLUMBING

IMPORTANT

Before installing the heat pump ensure the blanking disks are removed from the pool water in/out connections. These should drop out when the adaptors are unscrewed.

1. Ensure that bypass is installed and set to achieve the recommended flow rates stated in the data sheet.
2. Ensure that the condensate drain kit supplied is fixed and is drained to a drain or soak-away.

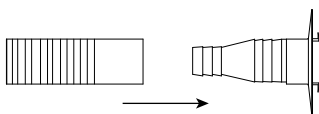
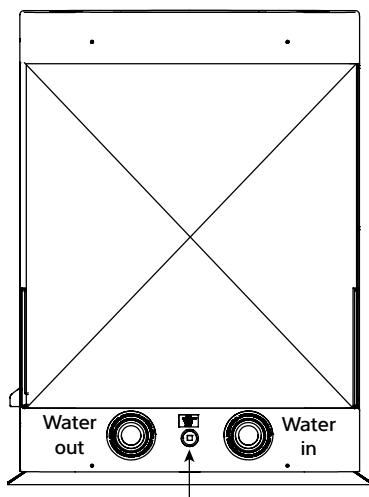

3. Inlet and outlet pipework must be supported to avoid excessive strain on the connections.
4. Water quality must be maintained. See warranty conditions.

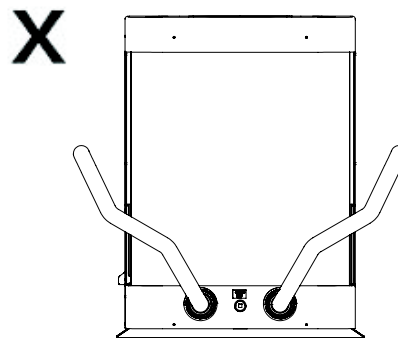
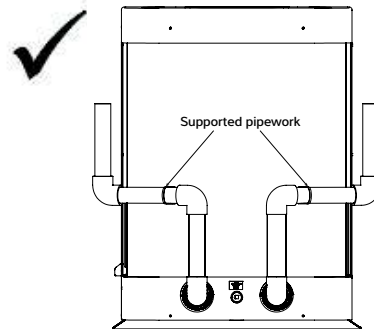

3.5 INITIAL CHECKS

Start the filtration pump before the heat pump is turned on and turn off the heat pump before the filtration pump. It is recommended to turn off the heat pump prior to backwashing.

Before starting the heat pump, please check for any leakage of water; and check/set the required temperature on the controller, and then turn on.

In order to protect the components, the heat pump incorporates time delays. When starting heating/cooling the fan will run for one minute before the compressor starts. The heat pump runs for a minimum of 5 minutes. When the heat pump stops heating/cooling, or is turned off by the user, the fan will continue to run for one minute.

After starting up, check for any error codes or abnormal noise from the heat pump.

3.6 ELECTROLYTIC CORROSION IN SWIMMING POOLS

Electrolytic corrosion will occur when dissimilar metals that are in contact with each other create a potential difference between themselves. Sometimes separated by a conductive substance known as an electrolyte, the dissimilar metals will create a small voltage (potential difference) that allows the ions of one material to pass to the other.

Just like a battery, ions will pass from the most positive material to the more negative material.

Anything more than 0.3 volts can cause the most positive material to degrade.

A swimming pool with its associated equipment can create this effect. The pool water being an ideal electrolyte and components of the filtration circuit, heating system, steps, lights etc providing the dissimilar metals needed to complete the circuit.

Whilst these small voltages are rarely a safety threat, they can create premature failure through corrosion. Not dissimilar to corrosion through oxidation, electrolytic corrosion can cause complete failure of a metallic material in a very short period of time.

In order to prevent this type of corrosion all metallic components in contact with swimming pool water should be bonded together using 10mm² bonding cable. This includes non-electrical items such as metal filters, pump strainer boxes, heat exchangers, steps and handrails. It is highly recommended that bonding be retrofitted to existing pools, which may not be protected by this system.

3.7 ELECTRIC WIRING AND SUPPLY

All electrical work to be carried out in accordance with I.E.E.regulations, latest issue, or local codes of practice as applicable. .

The machine should be installed in accordance with EMC2004/108/EC.

Always isolate the main power supply before removing machine covers.

The machine power supply must incorporate the following. Fuses or motor type circuit breakers (aM Fuse / MCB type C) to specified rating (see datasheet). When using a fuse, H.R.C. fuses are recommended. An isolator which disconnects all poles must be fitted within 2m and in line of sight of the heat pump. The isolator must have a minimum of 3mm air gap when turned off.

All units must be correctly earthed/grounded and its own separate type F RCD earth leakage trip installed which protects the machine only.

The following limits of operation must not be exceeded. Failure to provide the necessary voltages will invalidate the warranty. This voltage must be available at the heat pump whilst running. The voltage must not drop below the above figures when starting the compressor.

	Minimum	Maximum
Voltage		
Single phase machines	207V	253V
Cycle frequency (50Hz)	47.5Hz	52.5Hz

3.8 CONNECTING THE HEAT PUMP TO THE POWER SUPPLY

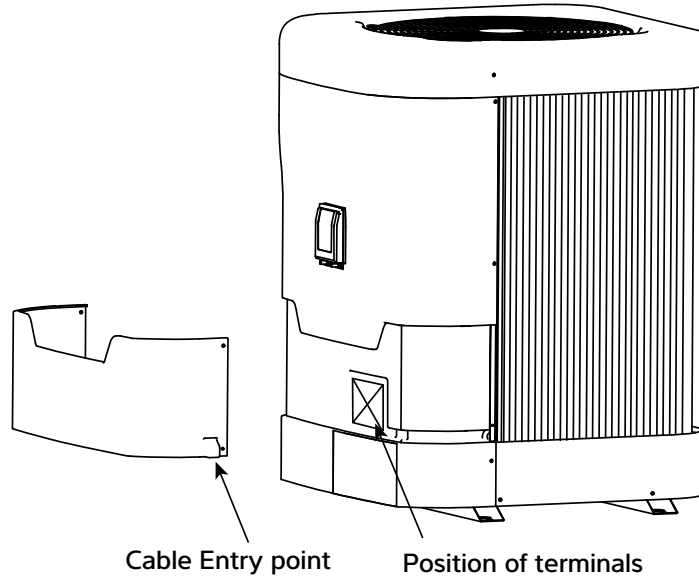

Single phase

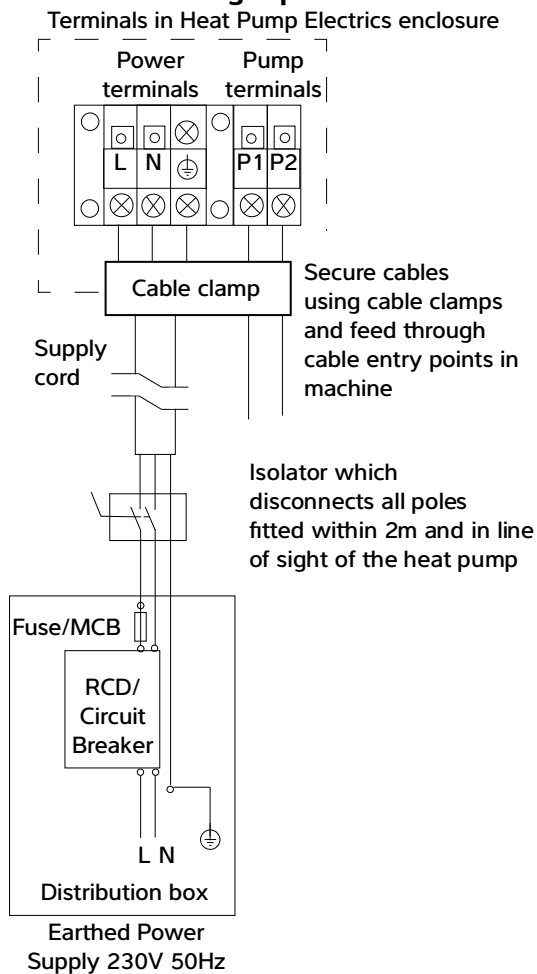

3.9 POOL PUMP OVERRIDE

TERMINALS P1/P2

For installations where the pool filter pump runs continuously, these terminals do not need to be used.

For installations where a timeclock controls the pool filter pump, and the same pump provides water flow to the heat pump, the heat pump can override "pump off" periods to ensure the pool is heated/cooled. To activate this setting please speak to your installer.

When installed in parallel with the timeclock, the pool filter pump will run when:

- a) a period of "pump on" has been set on the time clock for filtration purposes.
- b) a period of "pump off" has been set in the time clock and the heat pump runs the pool filter pump for temperature sampling and if the pool subsequently requires heating/cooling.

This feature operates by over-riding the timeclock whenever the controller measures a water temperature that needs heating/cooling. If the pool does not need heating/cooling the filter pump will be turned off until the controller next measures a water temperature that needs heating/cooling. If the pool needs heating/cooling the heat pump will continue to run the filter pump and heat/cool the pool.

This feature will reduce the pool filter pump run time to minimise pump energy usage.

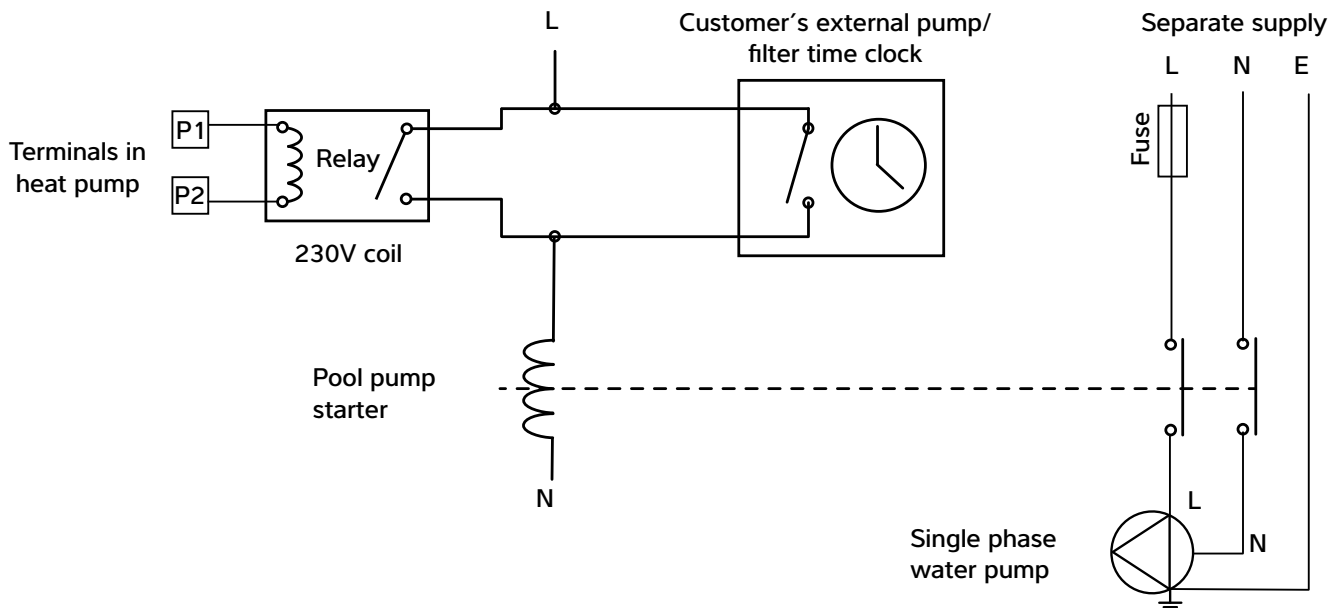

4.0 USING YOUR HEAT PUMP

4.1 THE KEY PAD

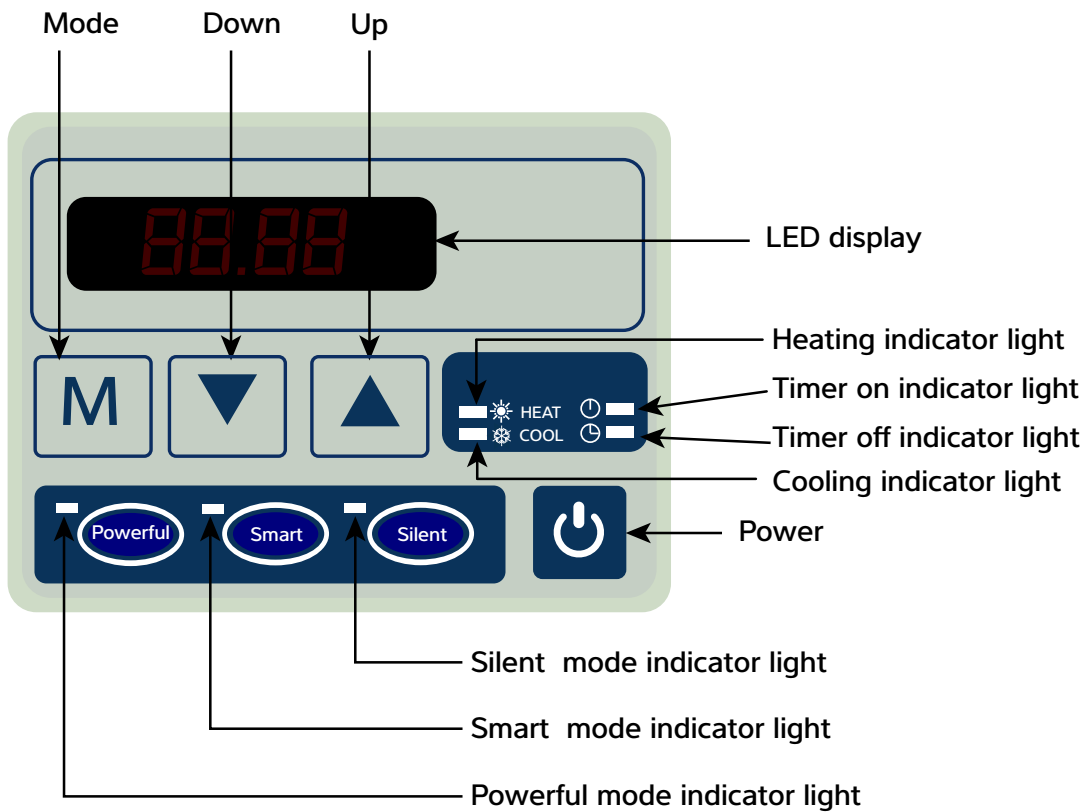

Note: When the heat pump is powered off, the display shows the time.

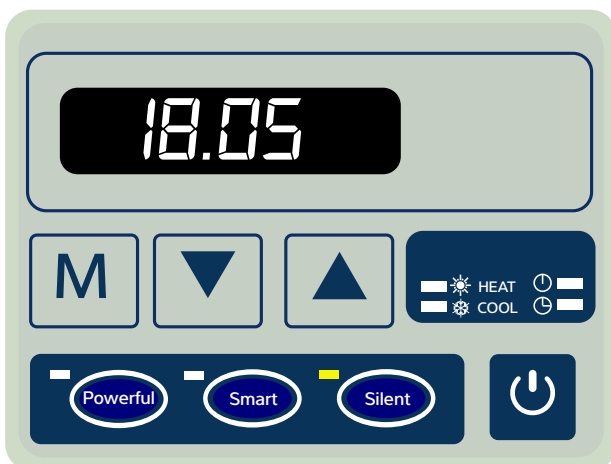

4.2 OPERATING INSTRUCTIONS



IMPORTANT

Remember that at startup there is a 1 minute time delay before the heat pump starts

a. Power on.



Press  to power the unit on or off. Note, a short press will return the controller to main menu.

b. Temperature setting.

Press  and  to display and adjust the set temperature. Press  to save settings and return to main screen.

c. Mode Selection

Press  to enter mode.

-  Powerful mode indicator lamp lit.
-  Smart mode indicator lamp lit
-  Silent mode indicator lamp lit

d. Heat mode selection



Press  to switch between heating and cooling.

Heating= Heating indicator lamp lit and H on display.











Cooling= Cooling indicator lamp lit and C on display.

e. Defrosting





1. Automatic defrosting. When machine is defrosting the heating indicator lamp flashes; after defrosting the flashing stops.

2. Forced Defrosting. When machine is heating and the compressor has been running continuously for 10 minutes. Press  and  together for 5 seconds. the heating mode lamp flashes and defrost starts. When defrosting is exited the display returns to normal.

f. Clock Setting

Turn the heat pump off via the . Press  to enter the clock settings. Press  and the hour flashes. Using the  and  set the hour. Press  again to make the minutes flash and use the  and  to set. Press the  once more to return to the main display. Press the  to turn the heat pumps back on.

g. Timer Setting

Press and hold the  for 5 seconds to enter timer menu. It will now show the 'timer on' time. Press  and the hour flashes. Use ▲ and ▼ to set the hour. Press  again and the minutes flash. Use the ▲ and ▼ to adjust these. Press  again to and it will now show the 'timer off' time. Adjust these in the same way as the 'timer on'. Once complete press  to save the setting.

h. Cancel timer

There are two ways to cancel the timer settings.

1. Both the timer on and timer off are set to the same time.

2. When in the interface for timer settings press and hold for 5 seconds the  to cancel each time individually. Note. must cancel 'Timer off' before 'timer on'.

5.0 TESTING

Inspect heat pump before use

- Check that the fan, air inlets and outlets are not obstructed.
- It is prohibited to install refrigeration pipe or components in corrosive environment.
- Check that the electric wiring conforms to the electric wiring diagram and that the machine is earthed.
- Double check that the main power switch is off.
- Check the temperature setting.

a. Machine diagnostics.

To aid machine diagnosis the heat pump can report on some conditions. These are shown in the table below.



To access these readings press and hold the  for 5 seconds, and use the ▲ and ▼ to scroll through.

The first number that is flashing is the parameter code.

Press  to return to main menu.

b. Factory reset

Press and hold the  and  together for 5 seconds. this enters the customer parameter menu.

Press and hold the  and  together for 5 seconds again and the reset is done. The buzzer will sound twice and all parameter values will change back to their default values.

QUERY CODE	MEANING	RANGE
1	Water inlet temperature	-20~99°C
2	Water outlet temperature	-20~99°C
3	Ambient temperature	-20~99°C
4	Compressor exhaust gas temperature	0~125°C
5	Compressor suction gas temperature	-20~99°C
6	Evaporator coil temperature	-20~99°C
7	Condenser coil temperature	-20~99°C
8 to 14		Ignored

5.1 HEAT PUMP MALFUNCTION

WARNING: Isolate heat pump electrically, and wait 3 minutes before removing panels or entering heat pump.

- Refer to the user check list in section 5.2 and the error codes listed in section 5.3 before initiating a service call.
- Do not attempt to interfere with any internal control settings as these have been factory calibrated and sealed.
- Any sign of abnormal operation such as water dripping should be reported immediately to the installer. If in doubt or if advice is required contact the Service support team on telephone +44(0)1621 856611 (option 4).

Fault	Reason	Solution
Heat pump doesn't run	No power	Wait until the power is restored
	Power is switched off	Switch on the power
	Fuse has blown	Check and change the fuse
	The breaker is off	Check and turn on the breaker
Fan running but with insufficient heating	Evaporator blocked	Remove the obstructions
	Air outlet blocked	Remove the obstructions
	3 minutes start delay	Wait for the delay timer to time out
Display normal, but no heating	Set temperature too low	Set desired heating temperature
	3 minutes start delay	Wait for the delay timer to time out
Inaccurate switch action.	Stop the machine, and cut off the power supply immediately, then contact your dealer	
The fuse blows frequently or leakage circuit breaker trips frequently		
If above solutions don't work, please contact your installer with detailed information and your model number. Don't try to repair it yourself.		

5.2 PROTECTION CODES

These codes indicate machine stopping due to external circumstances. These are not faults with the heat pump.

NO.	Display	Reason	Solution
1	Er 03	No water flow through the heat pump.	Check water circuit and pool pump.
2	Er 04	Frost protection. The heat pump runs in heating mode for a short time when in standby mode to prevent frost build up. This does not replace winterisation.	Heat pump will resume standby once process is completed.
3	Er 21	Ambient temperature is out of range, either lower than -5°C or higher than 43°C.	If outside, wait for ambient conditions to improve (winterisation may be required). If installed in a sheltered place, check for air recirculation.
4	Er 27	The temperature difference between inlet and outlet water is more than 10°C	Check water flow and pool pump.

5.3 FAULT CODES

When the heat pump displays any of these fault codes please contact your installer for advice.

Display	Description of fault code
Er 05	High pressure alarm
Er 06	Low pressure alarm
Er 09	Controller communication failure
Er 10	Inverter module communication error
Er 12	High exhaust gas temperature alarm
Er 15	Water inlet temperature sensor failure
Er 16	Evaporator coil temperature sensor failure
Er 18	Exhaust gas temperature sensor failure
Er 19	DC fan motor error
Er 20	Inverter module abnormal error protection
Er 23	Low outlet water temperature protection under cooling mode
Er 29	Compressor suction gas temperature alarm
Er 32	High outlet water temperature protection under heat mode
Er 35	Compressor high current protection
Er 42	Condenser coil temperature sensor failure

6.0 MAINTENANCE



Isolate the power supply of the heat pump and wait 3 Minutes before cleaning, examination or repair.

Cover the heat pump body when not in use.

Please clean this heat pump with household detergents or clean water, NEVER use petroleum spirit, thinners or any similar fuel.

Check bolts, cables and connections regularly.

Repair, service and disposal of redundant heat pumps must be completed by authorised technicians. It is illegal to allow refrigerant gases to escape to air.

Do not attempt to work on the equipment by yourself. Improper operation may cause danger.

7.0 TROUBLE SHOOTING COMMON FAULTS



Requirements for service personnel

Any person who is involved with working on or breaking into a refrigerant circuit should hold a current valid certificate from an industry-accredited assessment authority, F-Gas registered.

Do not attempt to work on the equipment by yourself.

8.0 DATA SHEET

MODEL		UNITS	VPT 12ALX	VPT 16ALX	VPT 22ALX
PERFORMANCE - Air 27°C Water 27°C RH 80%					
Heating capacity			14.1	18.5	24.4
COP Range			13.5-6.28	13.5-6.03	13.5-5.14
Average COP at 50% Speed			9.7	9.3	8.8
PERFORMANCE - Air 15°C Water 26°C RH 70%					
Heating capacity	kW		10.64	13.61	17.8
COP Range			8.5-5.11	8.4-5.02	6.2-4.14
Average COP at 50% Speed			6.5	6.4	4.7
TECHNICAL SPECIFICATION					
Operating air temperature	C		-5°C to 43°C		
POWER SUPPLY			230V Single Phase 50Hz		
Rated input power	kW		0.20-2.24	0.23-3.06	0.75-4.75
Rated input current	A		1.21-8.9	1.23-12.0	3.45-19.6
Maximum input current	A		12.5	15.5	24.5
Rated RCD type F	mA		30	30	30
Rated Fuse aM/ MCB type C	A		16	20	32
Sound level at 10m	dB(A)		<29	<30	<30
Recommended water flow rate	m ³ /h		4.97	6.5	8.98
Water connection	mm		1 1/2" and 50mm		
GENERAL DATA					
Net dimension LxWxH	mm		650x650x835	650x650x835	745x752x967
Packed dimension LxWxH	mm		670x670x870	670x670x870	770x770x980
Net weight	kg		70	80	95
HERMETIC SYSTEM					
Refrigerant charge R32	g		800	800	1700
Minimum area requirement	m ²		5.4	5.4	24.6

NOTES

Heat pump performance parameters are subject to change without notice.

Always refer to the nameplate.

Global warming potential (GWP) R32 - 675.

The data is subject to modification without prior warning.

OWNER/INSTALLATION MANUAL

9.0 DIMENSIONS

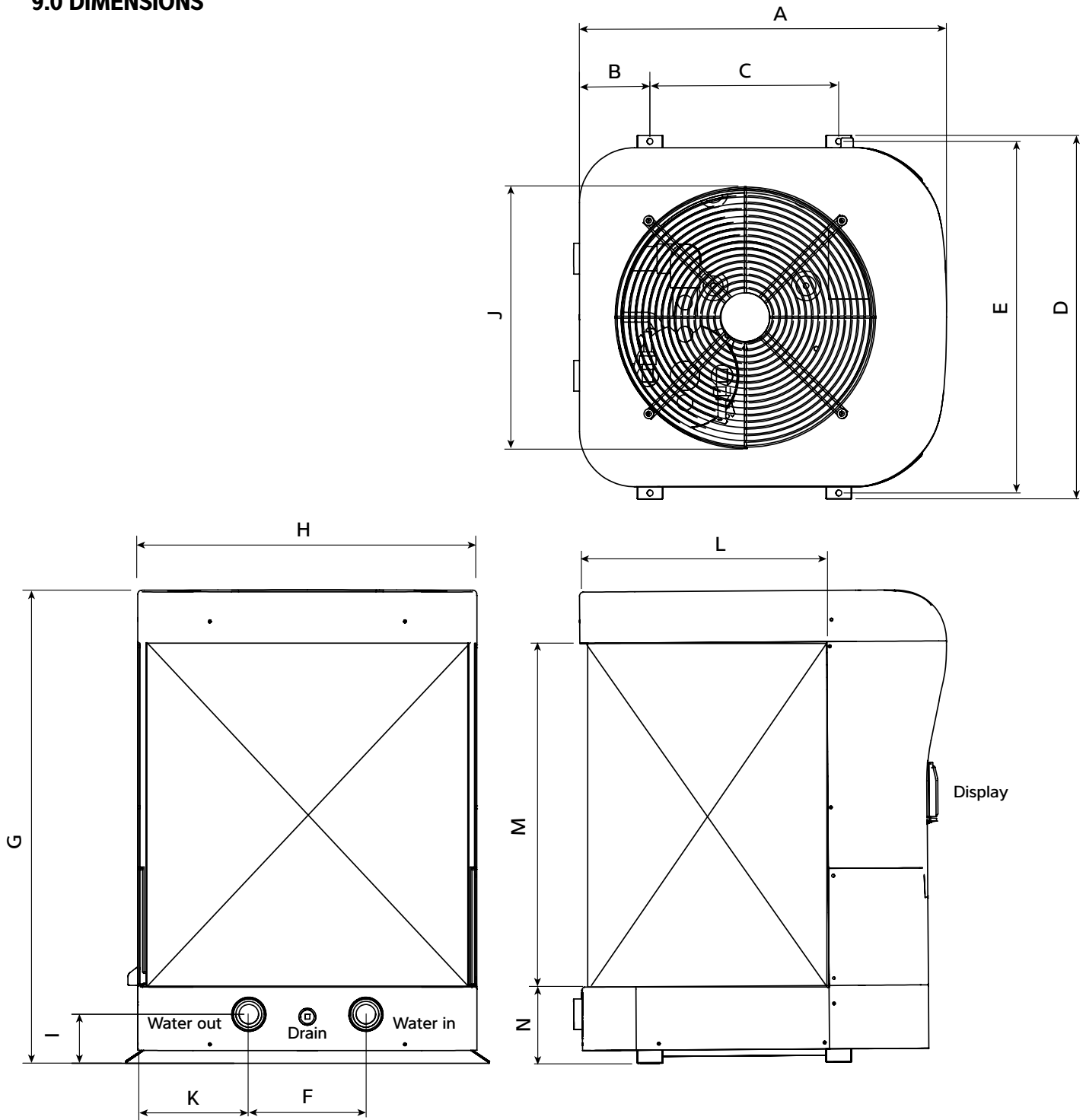

	A	B	C	D	E	F	G	H	I	J	K	L	M	N
VPT12 ALX	650	98	362	650	626	220	835	600	92	490	190	430	588	130
VPT16 ALX	650	98	362	650	626	220	835	600	92	490	190	430	588	130
VPT22 ALX	752	138	387	745	721	240	967	695	92	530	228	505	705	157

10.0 WINTERISATION PROCEDURE

WARNING. Isolate machine before opening! As heat pump embodies electrical and rotational equipment, it is recommended for your own safety that a competent person carries out the following procedure.

(Drain Down Procedure)

ALL MODELS

Objective

To provide frost protection

To eliminate corrosion problems

To inhibit electrical components

1. Switch off electrical supply to heat pump.
2. Remove external fuses and keep in safe place away from heat pump to prevent accidental operation of heat pump.
3. Ensure water circulation pump is switched off.

4. Drain water from heat pump by:
 - a) Drain valve if fitted.
 - b) Disconnecting pipework to and from heat pump.
 - c) Remove condenser drain down cover.
 - d) Flush through water circuit in heat pump by using CLEAN TAP WATER (NOT POOL WATER) via hose into outlet connection – run for 10 minutes minimum, use spray nozzle if available.
 - e) Allow to drain – fit plastic bags secured by elastic bands over water connections.
5. Uncover electrical enclosure (page 17) and liberally spray interior of unit, with moisture repellent aerosol WD-40 or similar, reseal enclosure.
6. If heat pump located outside, protect from weather by covering with VENTILATED cover. A bespoke cover is available. Do not use plastic sheet as condensation can occur within unit.

If this procedure is not adopted and frost or corrosion damage results then the warranty will become invalid.

10.1 START UP PROCEDURE AFTER WINTERISATION

1. Replace covers (if not fitted).
2. Remove front grille – using soft brush clean finned surfaces of heat pump. Replace panel.
3. Remove plastic covers on water connections and reconnect water piping or close drain valve.
4. Start up water circulating pump and leave running for at least ¼ hour to establish flow and enable any air in system to escape.
5. Replace fuses to heat pump circuit.
6. Switch on heat pump.
7. Check control thermostat is set to required pool temperature.
8. Check daily to ensure pool water is at correct pH and has correct chemical balance. See section 11.0 Warranty conditions.

11.0 WARRANTY CONDITIONS

The following exclusions apply to the warranty given by Dantherm Ltd. No claims will be accepted if:

1. The heat pump is installed in any way that is not in accordance with the current procedures as defined by Dantherm Ltd.
2. The heat pump has been worked upon or is adjusted by anyone other than a person authorised to do so by Dantherm Ltd.
3. The heat pump is incorrectly sized for the application.
4. The water flow through the machine is outside the specified limits.
5. The water pH level and/or chemical balance is outside the following limits:

Acidity pH	pH	7.2 - 7.8
Total Alkalinity, as CaCO ₃	ppm	80 - 120
Total Hardness, as CaCO ₃	ppm	150 - 250
Total Dissolved Solids	ppm	1000
Maximum Salt Content	ppm	35000
Free Chlorine Range	ppm	1 - 2 Domestic
Free Chlorine Range	ppm	3 - 6 Commercial
Super-chlorination	max	30ppm for 24 hrs
Bromine	ppm	2 - 5
Baquacil	ppm	25 - 50
Ozone	ppm	0.9 Max
Maximum Copper Content	ppm	1
Aquamatic Ionic Purifier	ppm	2 Max

6. The heat pump has suffered frost damage.
7. The electrical supply is insufficient or in any way incorrect.

8. The fan amps and duct pressure are outside the specified limits.
9. The air flow to and from the machine is outside the specified limits.

If in doubt or if advice is required please contact the Dantherm Group UK Service Department by calling +44 (0)1621 856 611 (option 4) or email service.department@dantherm.com

Please give **MODEL NUMBER** and **SERIAL NUMBER** of your heat pump when making technical or service enquiries. This will assist in correct diagnosis and ensure service can be provided with the minimum delay.

12.0 DECLARATION OF CONFORMITY



DANTHERM 

Dantherm Ltd.
Unit 12, Galliford Road
Maldon CM9 4XD
United Kingdom

+44 (0)1621 856611
sales.uk@dantherm.com
danthermgroup.co.uk
VAT: GB 223 5572 21

DECLARATION OF CONFORMITY

We hereby certify that the following Calorex models:

VPT12ALX, VPT16ALX and VPT22ALX range of electrically driven refrigeration heat pumps.

Conforms with

BS EN 60335-1:2012/A13:2017, BS EN 60335-2-40:2003/A13:2012, BS EN 62233:2008 and therefore comply with the Low Voltage Electrical Equipment Directive 2014/35/EU.

Conforms with

BS EN 55014-1:2017, BS EN 55014-2:2015, BS EN 61000-3-2:2014, BS EN61000-3-3:2013, BS EN61000-3-11:2000, BS EN61000-3-12:2011 and therefore comply with the Electromagnetic Compatibility Directive 2014/30/EU.

Complaint to RoHS Directive 2011/65/EC amended by Directive [EU] 2015/863

Falls outside the scope of the WEEE directive.

Don Kempster
Finance Director

Date 28-05-2020



AERIAL

calorex

Dantherm

MASTER

CAL-F16-143 Rev 03/16/2019

Dantherm Ltd.

Unit 12, Galliford Road
Maldon CM9 4XD
United Kingdom
+44 (0)1621 856 611
sales.uk@dantherm.com