

Installation Manual

PPT8/12/16/22LX/LY SLIMLINE



**OWNER/INSTALLATION MANUAL
FOR**

PPT8/12/16/22LX/LY SLIMLINE

(SD638150 Iss.13 30/06/15)

Health and Safety Warning:

As the heat pump includes electrical and rotational components it is required that only trained and competent persons should remove panels giving internal access to the unit.

SD638150 ISSUE 13

Installation Manual

PPT8/12/16/22LX/LY SLIMLINE



Thank you for choosing Calorex!

Your Calorex heat pump has been specially designed for pool heating using high quality components that are carefully chosen to provide maximum efficiency and reliability. Please read this manual carefully as it provides useful operation and maintenance information that will maximise the benefits your Calorex heat pump can offer.



+

ACCESSORIES

4 x ANTIVIBRATION PADS

2 x 50mm FEMALE PIPE ADAPTORS

1 x CONDENSATE DRAIN SOCKET 3/4"

1 X CONDENSATE DRAIN SOCKET 20mm

(IN HEAT PUMP ELECTRIC BOX)

QUICK START GUIDE

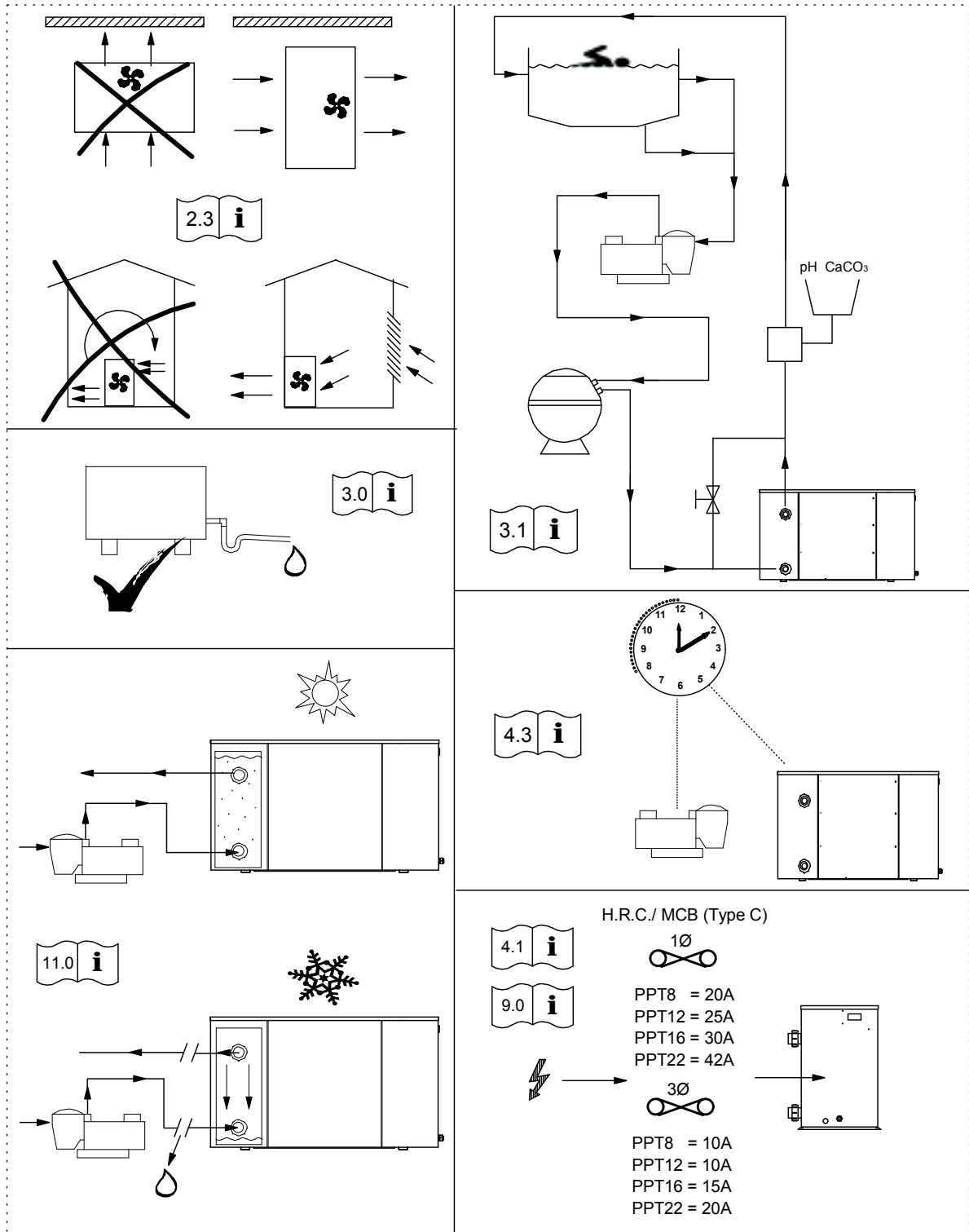



Contents

QUICK START GUIDE	i
1.0 Introduction	4
1.1 Function	5
2.0 Installation	6
2.1 Accessories	6
2.2 Siting	6
2.3 Air flow	7
3.0 Plumbing	8
3.1 Recommended Plumbing Schematic	10
3.2 Determining Water Flow	11
4.0 Electrolytic Corrosion in Swimming Pools	12
4.1 Electrical (Machine Wiring and Supply)	13
4.2 Location of Mains Input and External Interlock Terminals	14
4.3 Pool Pump Synchronisation	15
5.0 Digital Thermostat	16
5.1 Changing the position of the Digital Thermostat	17
6.0 Circuit Diagrams	18
7.0 Regular planned maintenance	23
7.1 Removal of Service Panels	23
8.0 Heat Pump Malfunction	24
8.1 User Check List	24
9.0 Datasheets	25
10.0 Installation Drawings	27
11.0 Winterisation Procedure	31
11.1 Start up Procedure After Winterisation	32
12.0 Warranty Conditions	33
13.0. Contacting Calorex	34
14.0 Machine Record Log	35



1.0 Introduction

The Calorex 'Propac' range of air to water heat pumps is designed for swimming pool heating and consists of 4 models. Heat pumps in this manual are designed to heat pool water and spas within the range of 10°C to 40°C. Standard units (designated X) are suitable for outdoor pools operating in ambient temperatures above 5°C. (Reverse cycle defrost models (designated Y) operate in ambient temperatures down to -15°C). The water heat exchanger is a full flow type, manufactured from titanium tube, which is a highly corrosion resistant material. The heat pumps are suitable for use in fresh water and salt water pools. PPT8/12 heat pumps are fitted with rotary compressors and PPT16/22 heat pumps are fitted with scroll compressors. Both types of compressor are known for quiet running. A 6 minute compressor start delay timer is incorporated for compressor protection. With these features the heat pump is designed to have a long, trouble free life.

All units have integral safety devices to protect the heat pump from internal and external faults. Indicator lamps indicate operating mode. An adjustable digital thermostat controls water temperature.

IMPORTANT

This appliance is not intended for use by persons (including children) with reduced physical, sensory or mental capabilities, or lack of experience and knowledge, unless they have been given supervision or instruction concerning use of the appliance by a person responsible for their safety.

Children should be supervised to ensure that they do not play with the appliance.

Calorex Heat Pumps Limited is an ISO9001:2000 certified company.

All Calorex heat pumps are CE approved

1.1 Function

The Calorex Swimming pool heat pump provides thermodynamic heating by means of a vapour compression cycle, (similar to that employed in a conventional refrigerator), in addition to acting as an active solar collector.

1. THE EVAPORATOR collects the heat from the outside ambient air, pre-heated by the sun. In the Calorex swimming pool heat pumps, high volumes of outside air are drawn into the unit by the fan expelled through the evaporator fins. The evaporator has liquid refrigerant passing through it which is at a considerably lower temperature than the ambient air. Therefore the air gives up its heat to the refrigerant which then vaporises. This preheated vapour now travels to -

2. THE COMPRESSOR where it is compressed and upgraded to a much higher temperature. The hot vapour now enters-

THE HEAT PUMP CYCLE

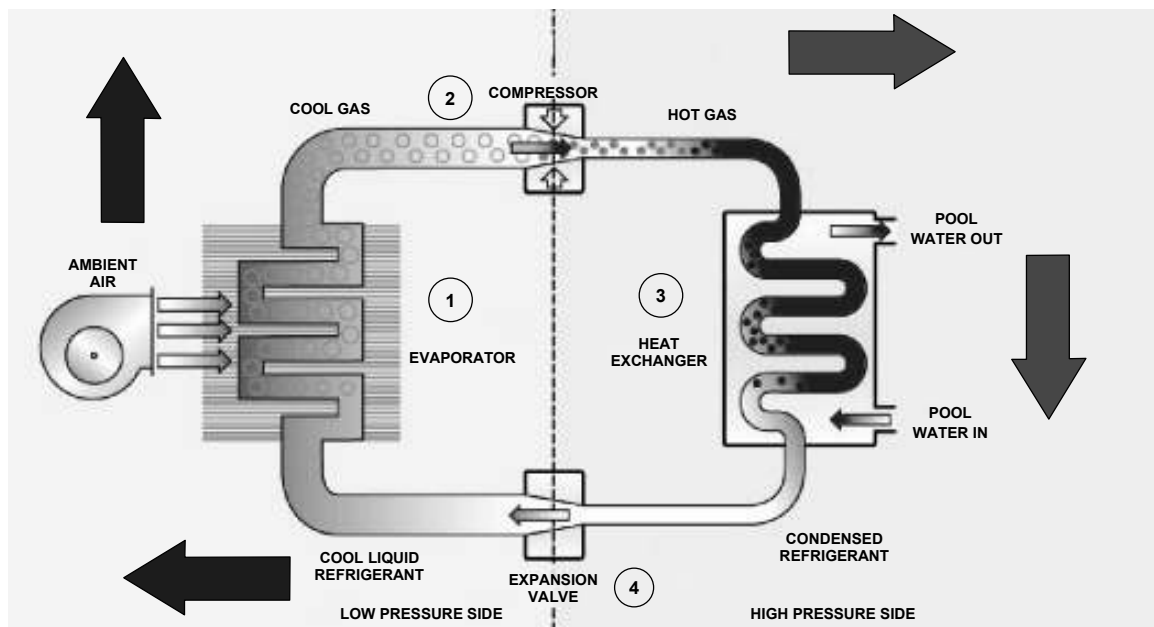

4. THE EXPANSION DEVICE and from there, now at normal pressure, it is returned to the evaporator and the cycle starts again.

3. THE CONDENSER where it is surrounded by the pool water. The heat is given up to the cooler pool water and the now cooler refrigerant returns to its former liquid state but still under high pressure from the compressor. This pressure is released by passing liquid through-

Coefficient of Performance

The efficiency of a Heat Pump is usually called its 'Coefficient of Performance' - (C.O.P.) which is simply a ratio of heat output to energy input, both being expressed in kW. Thus a Heat Pump absorbing 1 kW of electricity, collecting 4 kW of energy from the air, and delivering 5 kW of heat to the pool water is said to have a C.O.P. of 5:1.

This ratio will vary according to the temperature of the water and the ambient air.



2.0 Installation

- a) Ensure heat pump on site is as ordered, i.e. model, electrical supply and factory fitted options.
- b) Inspect unit for damage, in particular inspect the evaporator (finned side) to ensure that it is undamaged. (Minor indentations in the fins do not affect performance). If severely damaged, endorse delivery note in presence of the driver and send a recorded delivery letter to transport company giving details. Protect unit if installation is delayed.

2.1 Accessories

The heat pump is supplied with accessories which aid installation. On delivery the accessories are in a plastic bag in the heat pump electric box. (See section 4.2 for lid removal).

These accessories are as follows:

4 x rubber feet - Fit these under the metal feet of the heat pump to help reduce the effects of vibration.

2 x 50mm female connectors - On delivery the heat pump has 1 1/2" sockets attached to the water connections for fitting 1 1/2" plastic pipes. If 50mm pipework is preferred undo the threaded couplings on the water in/out connection points and carefully remove the 1 1/2" sockets. Then fit the 50mm sockets in their place and refit the threaded couplings. The heat pump can then be fitted with 50mm plastic pipe.

2 x Condensate drain piece - Condensate drain pieces are supplied suitable for 3/4" or 20mm pipe. Use whichever piece fits the drain pipe required. Glue the relevant piece to the drip tray outlet and then fit then condensate drain piping.

2.2 Siting

- a) Provide a firm level base capable of supporting operational weight of unit; spread load if mounted on timber floor.
- b) Ensure water cannot collect under unit, it is recommend that units are installed on plinths 100mm above finished floor level. This also aids condensate drainage.
- c) Allow adequate clearance to service panels on unit; recommend 500mm minimum.
- d) All Calorex heat pumps are by design as quiet as is practical, however due consideration should be given to siting the heat pump in order to minimise the noise coming from the machine, for example by positioning the machine so that the inlet/outlets are parallel to occupied premises.
- e) Ensure loose debris such as leaves, grass cuttings, etc will not block air inlet grilles.
- f) Consider protection from extreme weather conditions if installed externally, i.e. lean-to-cover or building.

2.3 Air flow

Due consideration must be given to air flow i.e. do not obstruct inlet or outlet and ensure discharge to air cannot recirculate to inlet. (See below).

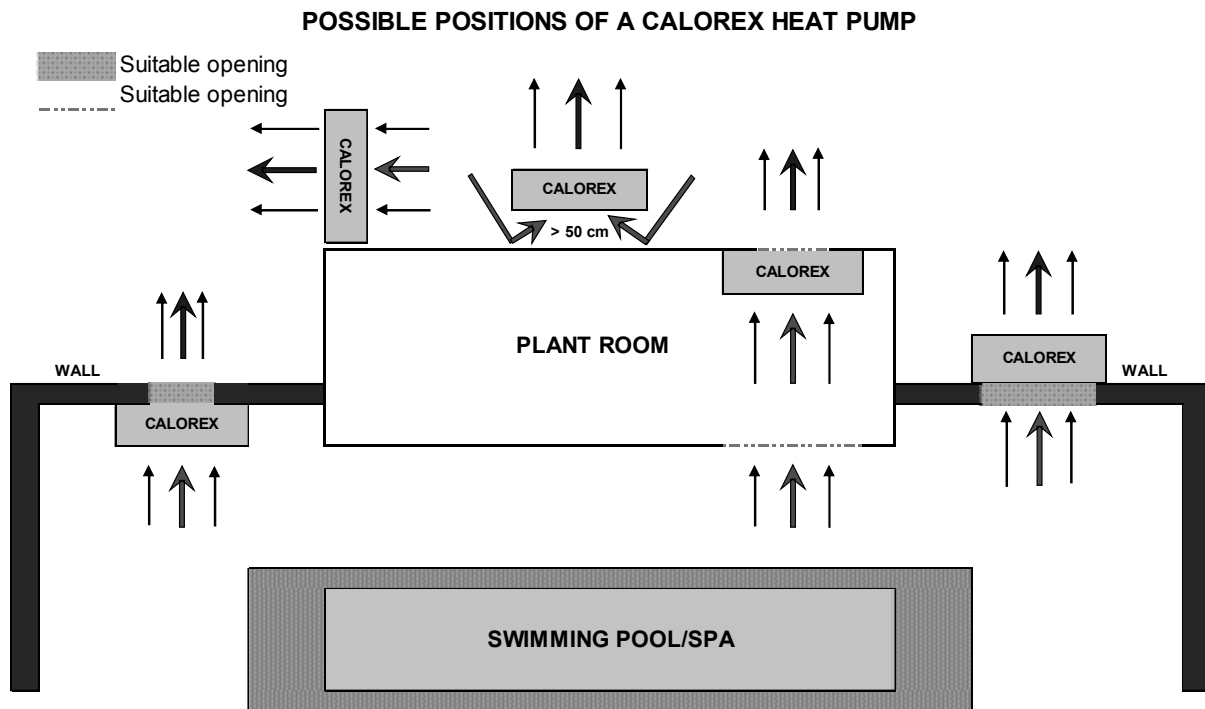

MODEL	TABLE 1 Minimum Free Area m ²	
	Inlet	Discharge
PPT8	0.157	0.168
PPT12	0.264	0.168
PPT16	0.322	0.173
PPT22	0.322	0.173

Required Free Areas to provide air flow to and from heat pumps when installed in an enclosed area or where required to pass air through a wall etc.

Free areas is the available area through which air can pass through a grille or louvres.

IMPORTANT

If multiple units are installed in an enclosed area then the inlet free areas required for each unit can be added together to form one inlet aperture. BUT discharge from each unit must be kept separate and must not be incorporated into one common duct system.

3.0 Plumbing

a) Calorex Heat Pumps have water inlet/outlet connections as follows:

All models have fittings which enable the heat pump to be connected to either 1 1/2" or 50mm pipe work.

b) The heat pump is supplied with bungs fitted in the water connection fittings. These need to be removed before the heat pump is installed. (See section 3.2).

c) The Calorex Heat Pump must be connected after the filter in the return pipe to the pool. If an existing heater is being retained, then the Calorex Heat Pump should be connected between the filter and the other heater. (See section 3.1).

d) Suitable breakable couplings should be installed local to the heat pump.

e) If the heat pump is installed at a lower level than the pool then isolation valves should be fitted.

f) A drain valve or plug should be fitted to the lower pipe to facilitate drain down in the winter period.

g) Connections on all models are by 1 1/2" or 50mm Female fittings. The water in/water out pipes need to be glued into these connections using a suitable adhesive.

h) The condensate drain at the base of the unit collects condensation from the evaporator fins. This should run away to waste via 3/4" domestic waste piping. It is therefore necessary to ensure that the Calorex Heat Pump is placed on a level plinth so that the condensate water can run away with adequate fall to waste i.e. 1/2" per foot minimum and must incorporate a "u" trap as to not overflow the edges of the drip tray inside the heat pump. See below.

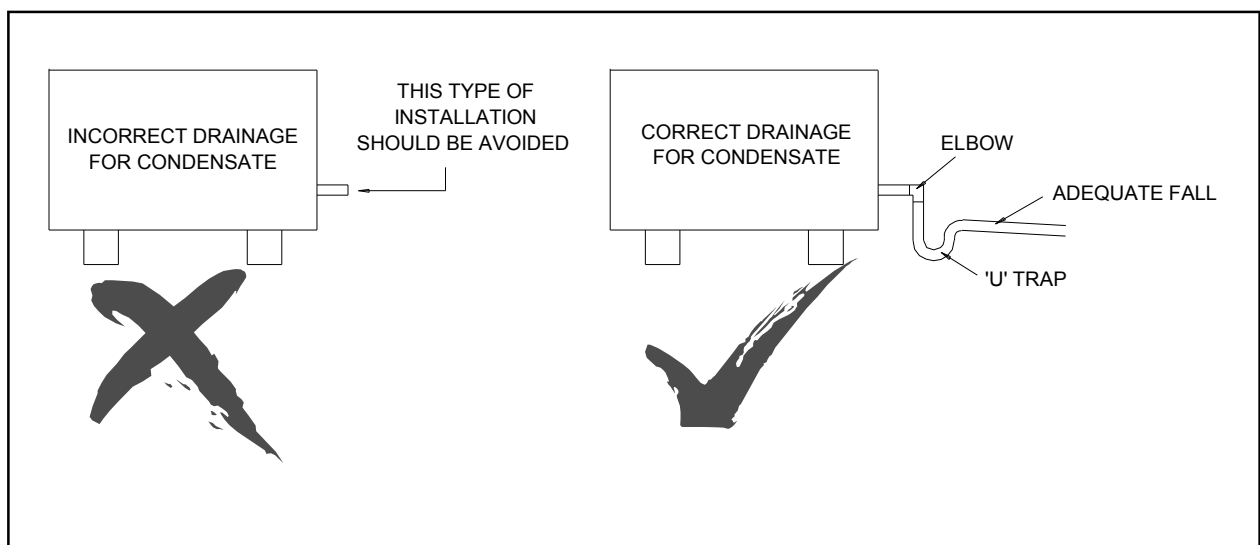



- i) When the pipework installation is complete the pool pump should be switched on and the system tested for leaks. Also check the filter gauge to see that there is not an excessive increase in back pressure. If everything is then working normally the water circulating system is ready for use.
- j) Water circuit to and from the unit is to be capable of maintaining within specified limits the rate of flow required by the heat pump. (See section 9).
- k) All pipework must be adequately supported with allowance expansion/contraction especially with plastic pipework.
- l) It is recommended that when installing water systems the last connections to be made in the system should be breakable connections to avoid any stresses on the unit connections.

IMPORTANT

1. All Pool Purifying Devices and Chemical Injection Systems to be fitted down stream of the heat pump (see section 3.1) unless installation is as per filter dosing. This includes the practice of dosing chemicals direct into skimmer basket, which results in concentrated corrosive liquids passing over vulnerable metal components.

2. Water quality must be maintained as follows:

Acidity pH	pH	7.2 - 7.8
Total Alkalinity, as CaCO ₃	ppm	80 - 120
Total Hardness, as CaCO ₃	ppm	150 - 250
Total Dissolved Solids	ppm	1000 Max
Maximum Salt Content	ppm	35000 Max
Free Chlorine Range	ppm	1 - 2 Domestic
Free Chlorine Range	ppm	3 - 6 Commercial
Superchlorination	max	30ppm for 24 hrs
Bromine	ppm	2 - 5
Baquacil	ppm	25 - 50
Ozone	ppm	0.9 Max
Maximum Copper Content	ppm	1
Aquamatic Ionic Purifier	ppm	2 Max

3. Maximum pressure of water in heat pump circuit should not exceed 2.5bar for PPT8/12 (35 psi) and 3.5bar for PPT16/22 (50 psi).

3.1 Recommended Plumbing Schematic

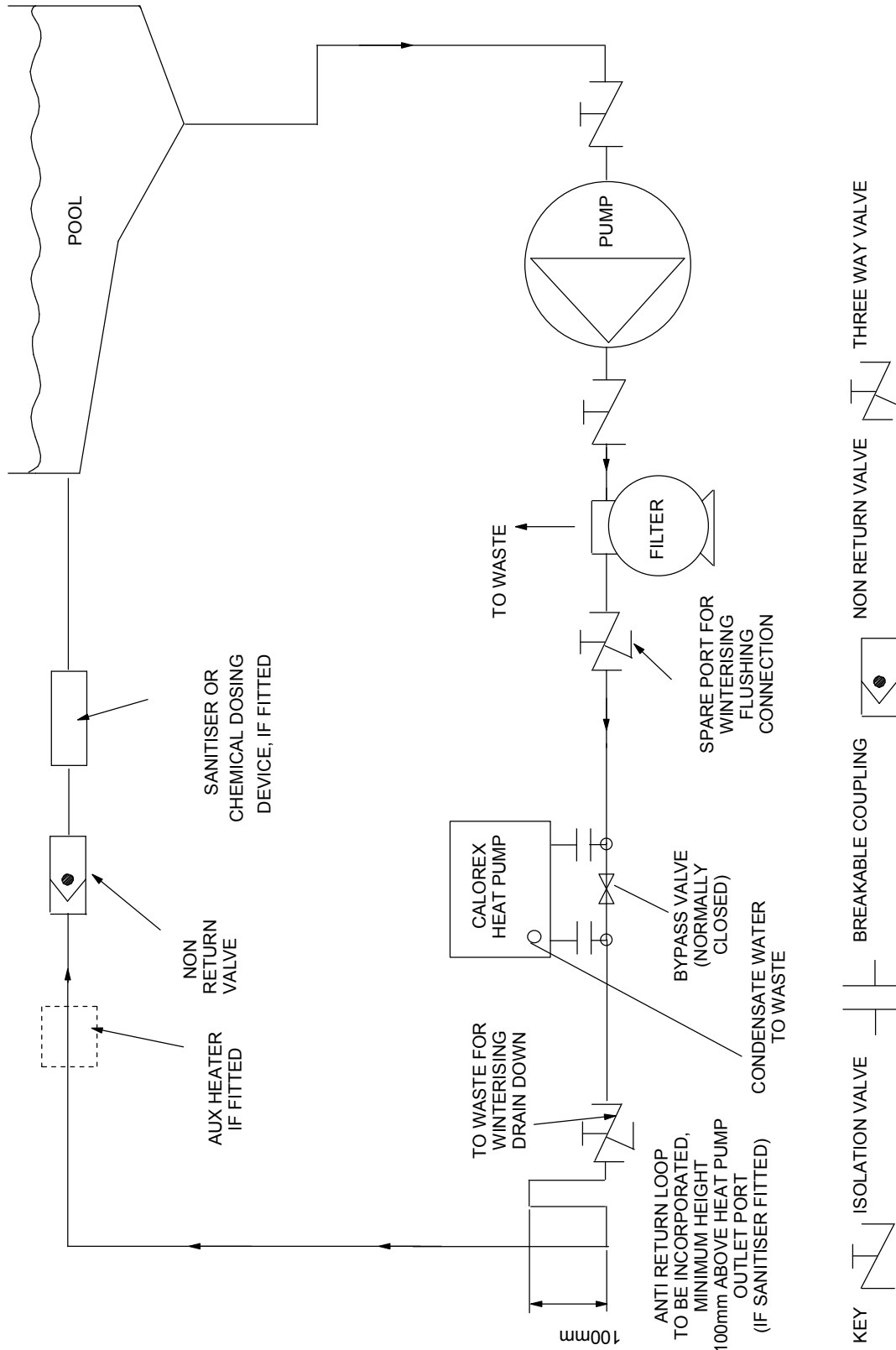

Installation Manual

PPT8/12/16/22LX/LY SLIMLINE



3.2 Determining Water Flow

The heat pump is fitted with a water flow switch which inhibits the operation of the heat pump when the water flow is less than the figure shown in the table below.

MODEL	Flow rates for water pressure switch	
	Machine starts working when flow rate rises above L/hour	Machine stops working if flow rate drops below L/hour
PPT8	1500	840
PPT12	1500	840
PPT16	2500	2000
PPT22	1920	1500

Adjust the flow rate until the flow rate is adequate. The display on the digital thermostat shows "noF" until adequate flow is reached.

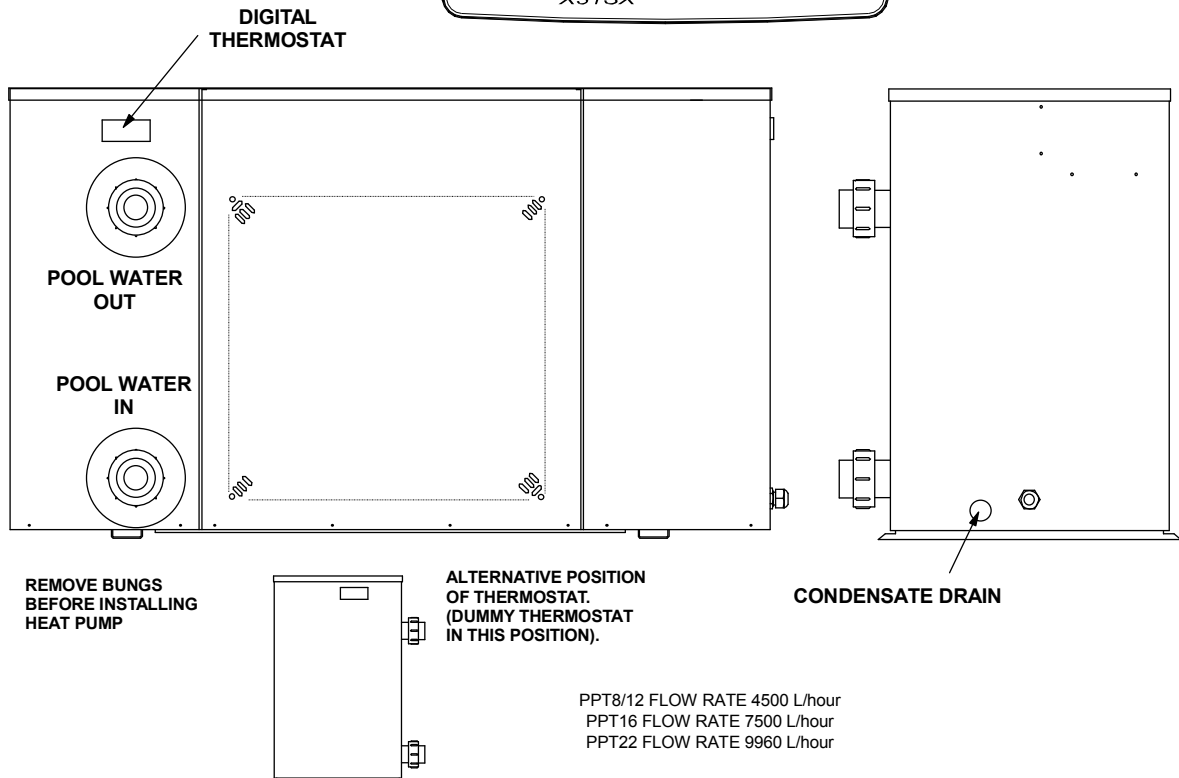
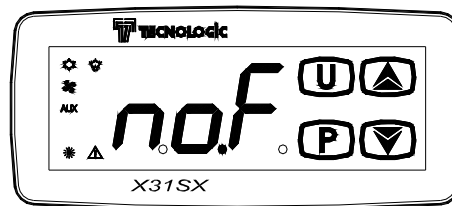



4.0 Electrolytic Corrosion in Swimming Pools

Electrolytic corrosion will occur when dissimilar metals that are in contact with each other create a potential difference between themselves. Sometimes separated by a conductive substance known as an electrolyte, the dissimilar metals will create a small voltage (potential difference) that allows the ions of one material to pass to the other.

Just like a battery, ions will pass from the most positive material to the more negative material.

Anything more than 0.3 volts can cause the most positive material to degrade.

A swimming pool with its associated equipment can create this effect. The pool water being an ideal electrolyte and components of the filtration circuit, heating system, steps, lights etc providing the dissimilar metals needed to complete the circuit.

Whilst these small voltages are rarely a safety threat, they can create premature failure through corrosion. Not dissimilar to corrosion through oxidation, electrolytic corrosion can cause complete failure of a metallic material in a very short period of time.

In order to prevent this type of corrosion all metallic components in contact with swimming pool water should be bonded together using 10mm² bonding cable. This includes non-electrical items such as metal filters, pump strainer boxes, heat exchangers, steps and handrails. It is highly recommended that bonding be retrofitted to existing pools, which may not be protected by this system.

Installation Manual

PPT8/12/16/22LX/LY SLIMLINE



4.1 Electrical (Machine Wiring and Supply)

All electrical work to be carried out in accordance with I.E.E. standards, latest issue, or local codes of practice as applicable.

The machine should be installed in line with EMC2004/108/EC.

Protected supply to incorporate fuses or motor type circuit breakers (Type C) to specified rating, (see Data Sheet). H.R.C. fuses are recommended. An isolator which disconnects all poles must be fitted within 2m and in sight of machine.†

All units must be correctly earthed-grounded. An earth leakage trip of the Current operating type (30mA) is recommended to be fitted to all pool electrics.

INCONSISTENT ELECTRICAL SUPPLY

The following limits of operation must not be exceeded if Calorex machines are to be guaranteed either in performance or warranty terms:

	<u>Minimum</u>	<u>Maximum</u>
Voltage single phase	207V	253V
Voltage three phase	360V	440V
Frequency - Hz	47,5	52,5

This voltage must be made available at the heat pump while running.

† Note the Isolator must have a minimum of 3mm air gap when turned off.

NOTE: Three phase heat pumps are fitted with a phase protection relay and will not run if the phases are not connected in the correct order (phase sequence) or if the supply voltage is 15% less than the nominal voltage (415V for 3N~ 50Hz). The lamp on the phase rotation relay (situated in the electric box is illuminated when the phases are correctly connected and the voltage is sufficient.

IMPORTANT

The user should be made aware that THE WHOLE installation should be isolated when working on ANY PART.

Installation Manual

PPT8/12/16/22LX/LY SLIMLINE



4.2 Location of Mains Input and External Interlock Terminals

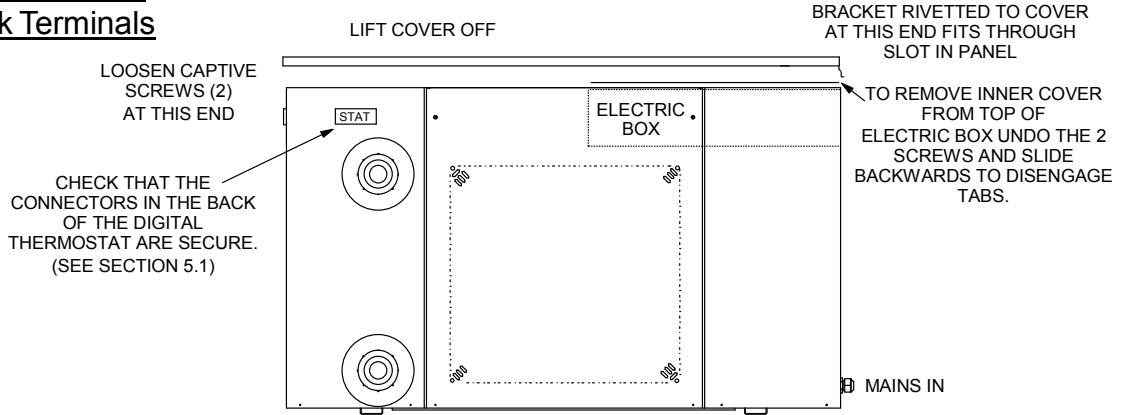

SINGLE PHASE 230V ~1N 50Hz

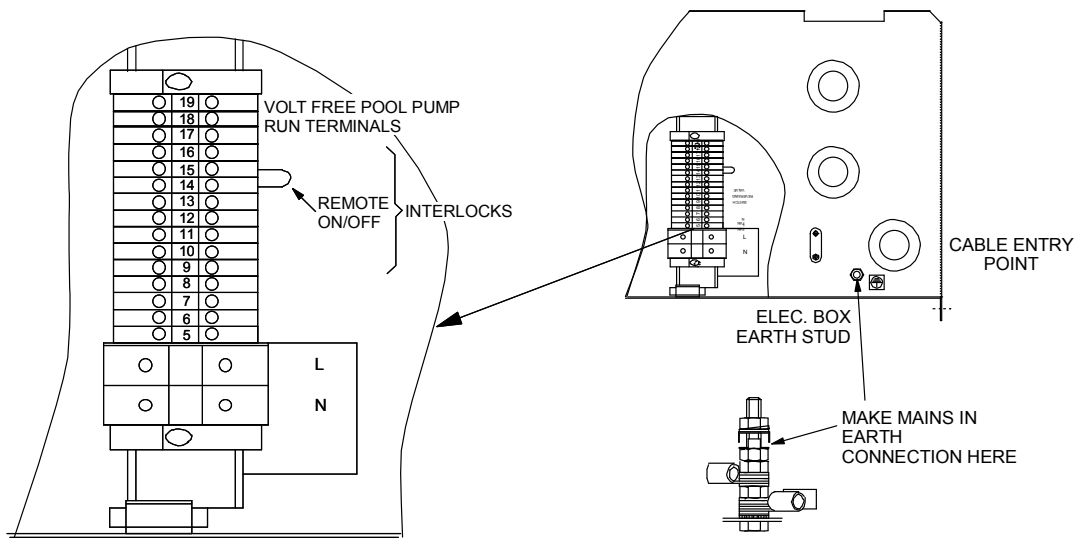

THREE PHASE 400V ~3N 50Hz

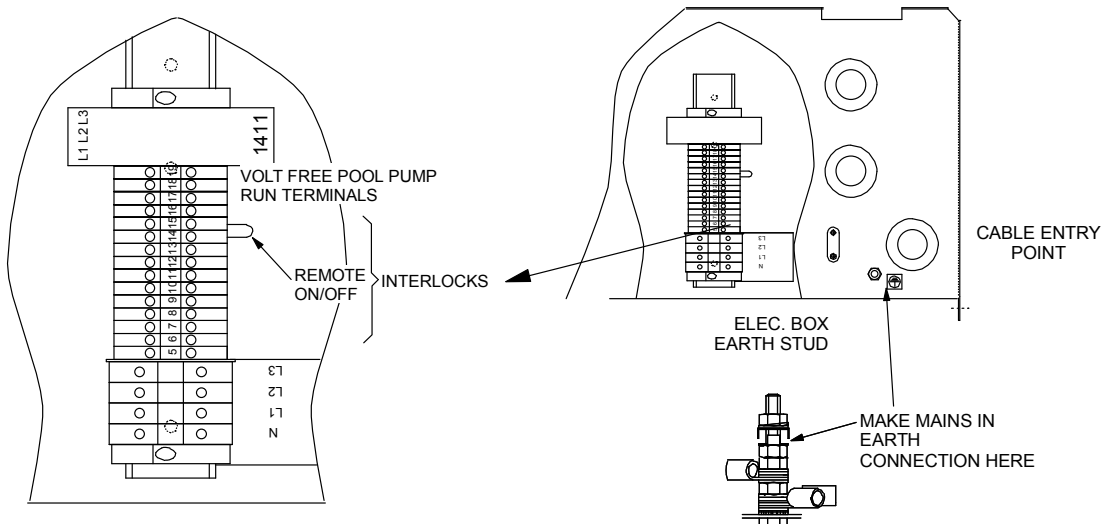

Installation Manual

PPT8/12/16/22LX/LY SLIMLINE



4.3 Pool Pump Synchronisation

For installations where the filter pump, which also provides water to your heat pump, is controlled by a time clock (supplied by the installer) your Calorex heat pump can override “pump off” periods set on the time clock so that the filter pump will run if your swimming pool requires heating. By doing so your filter pump will only run when:

- a) A block period of pump “running” has been set on the time clock for filtration purposes.
- b) The pool requires heating.

This feature operates by overriding the filter pump time clock for three minutes each hour so that water is pumped through the heat pump. If during this sampling period the heat pump detects a need for water heating it will continue to override the time clock until the swimming pool temperature is satisfied. If water heating is not required the filter pump will turn off after the three minute sampling period and not restart until the next hourly sampling period or time clock pre set run time. This feature will reduce filter pump run time and consequently save energy as well as unnecessary filter pump wear and tear.

A pair of volt free terminals (numbered 14 and 15) are available to allow for the heatpump to be switched on or off remotely.

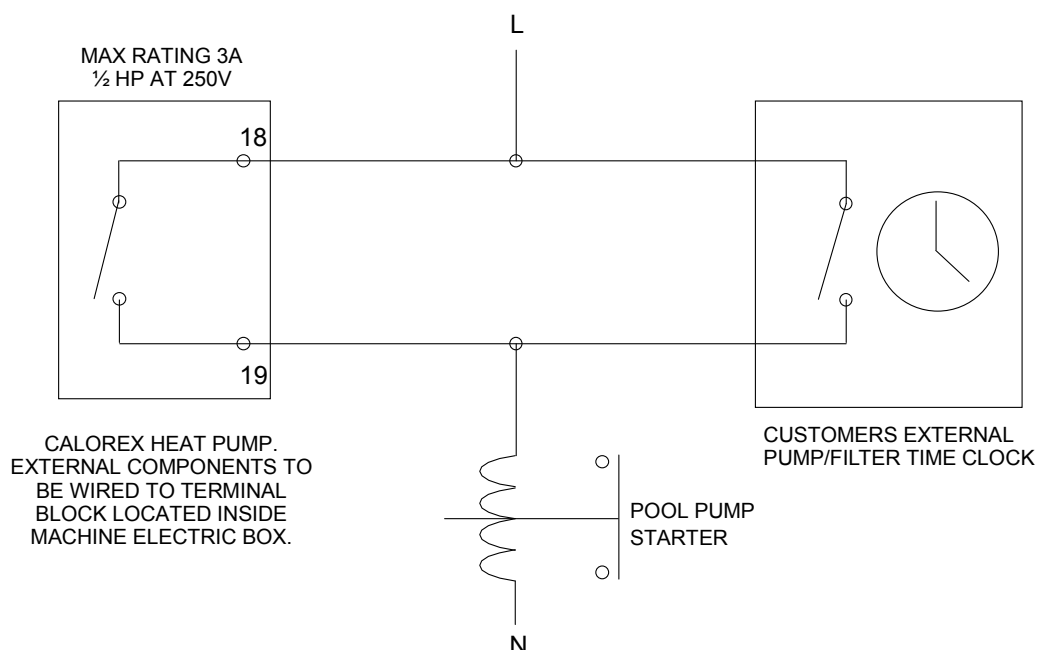

5.0 Digital Thermostat

An adjustable digital thermostat controls and maintains the water temperature and incorporates the indicator lamps. Press and release the P key to display required temperature. To alter required temperature press the up or down keys. After 5 seconds the display reverts to actual water temperature.

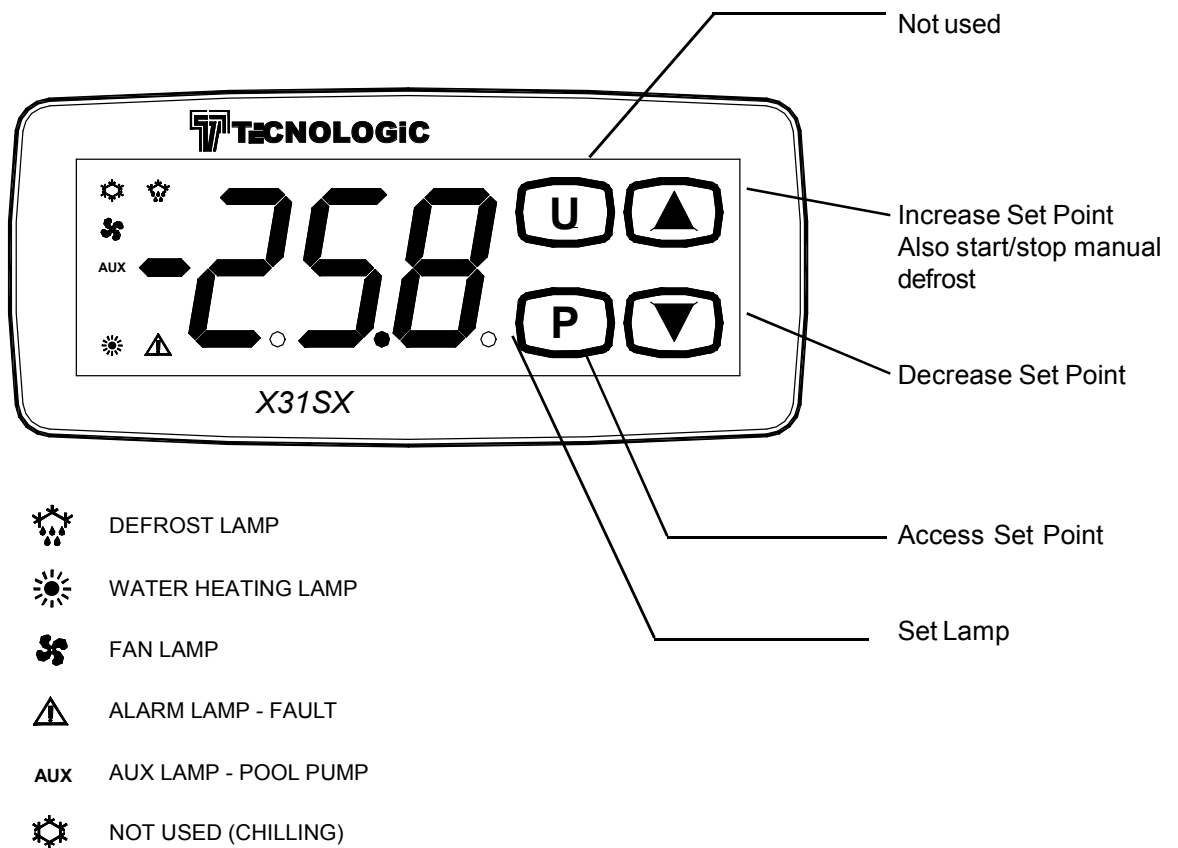



5.1 Changing the position of the Digital Thermostat

If the thermostat is not easily visible when the machine is installed, the position of the thermostat and the “dummy thermostat” can be exchanged. This can be done in easy stages, but should be done by a competent person.

1. Isolate the heat pump from the electricity supply.
2. Remove the lid of the heat pump (see section 4.2).
3. Remove the plugs connecting the wiring from the back of the thermostat.
4. Undo the white plastic clips securing the heat pump to the panel. This is done by pressing the clips in at the sides.
5. Remove the thermostat through the panel.
6. Remove the dummy thermostat from its position following the same method described in point 4.
7. Put the thermostat and dummy thermostat in their new positions and secure with white clips.
8. Re connect the connectors to the thermostat taking care that the red markers in the plugs and sockets are correctly aligned.
9. Replace the lid and reconnect the heat pump to the electrical supply.

Installation Manual

PPT8/12/16/22LX/LY SLIMLINE



6.0 Circuit Diagrams

PPT8/12 ALX/ALY SINGLE PHASE 230V~1N 50Hz

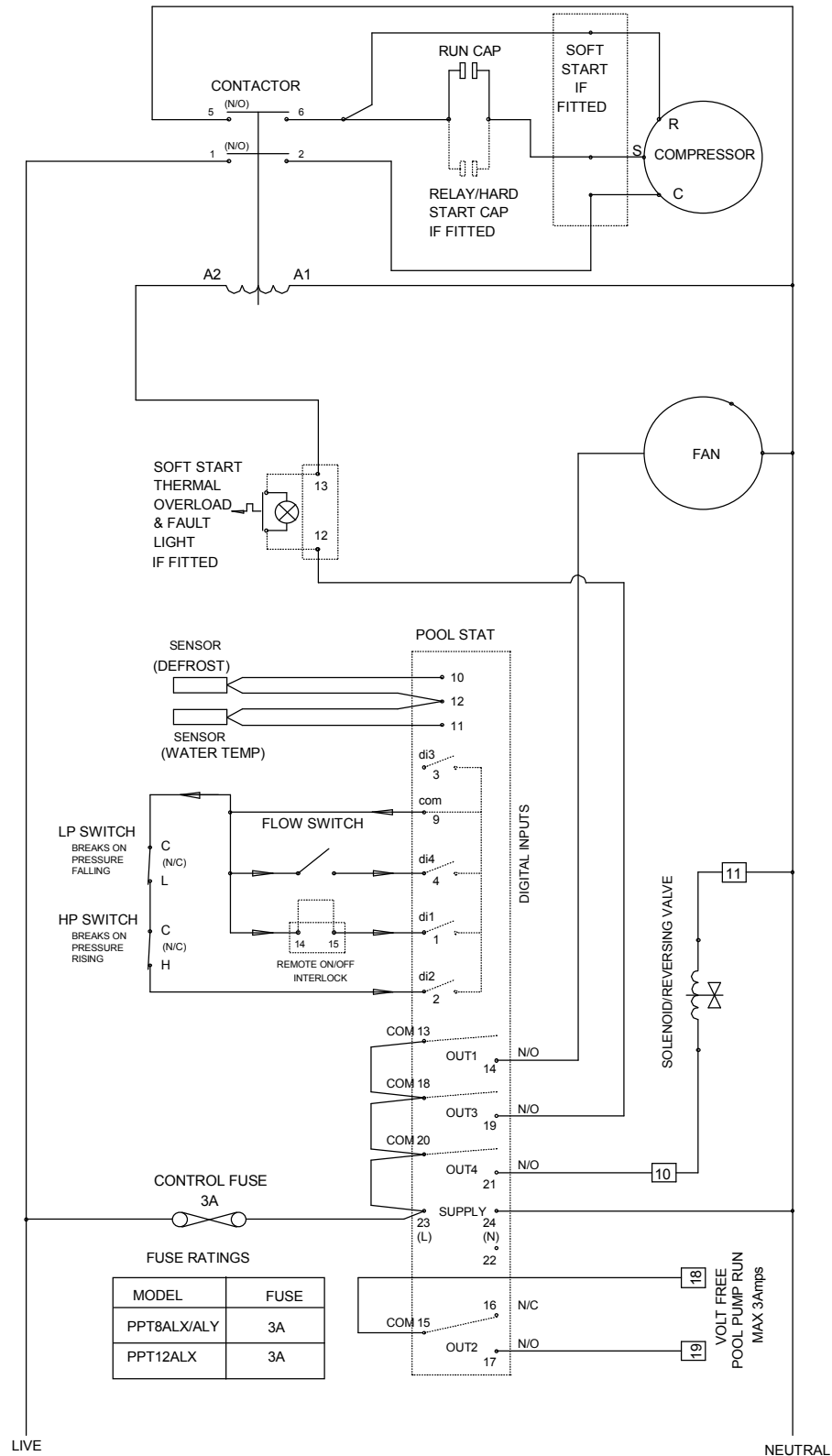

Installation Manual

PPT8/12/16/22LX/LY SLIMLINE



PPT16/22 ALX SINGLE PHASE 230V~1N 50Hz

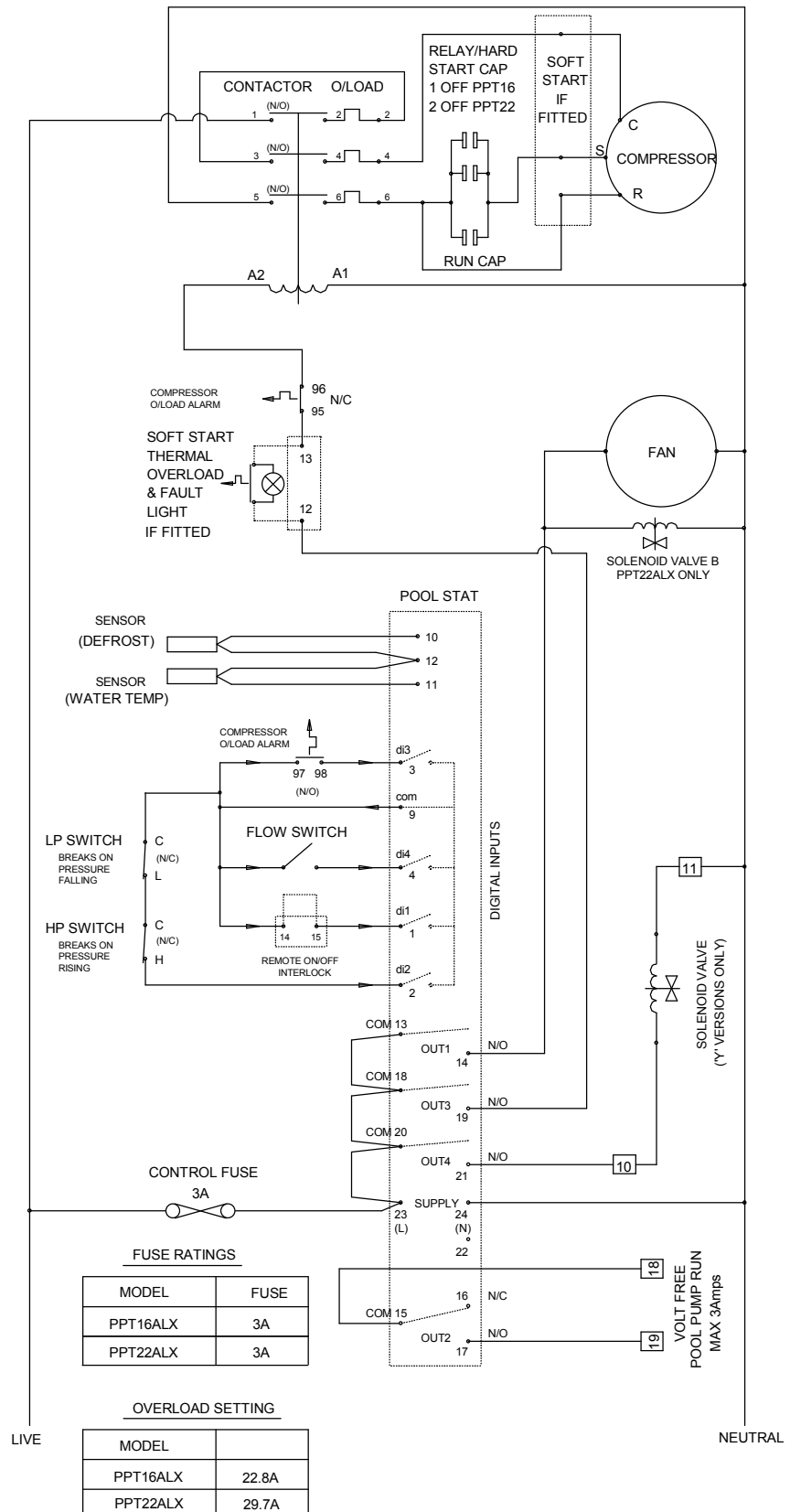

Installation Manual

PPT8/12/16/22LX/LY SLIMLINE



PPT12/16/22 BLX/BLY THREE PHASE 400V~3N 50Hz

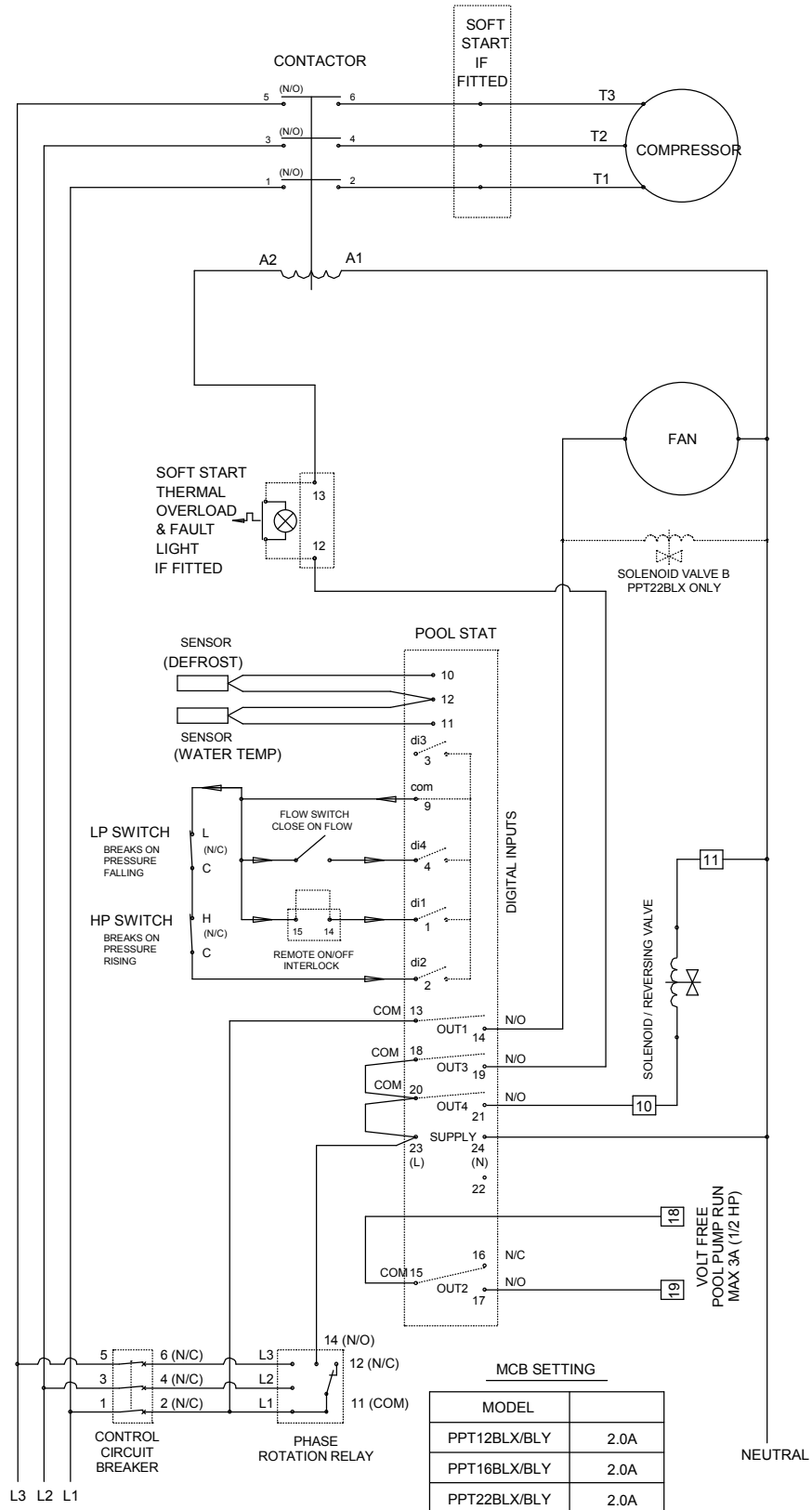

Installation Manual

PPT8/12/16/22LX/LY SLIMLINE



PPT16 ALY SINGLE PHASE 230V~1N 50Hz

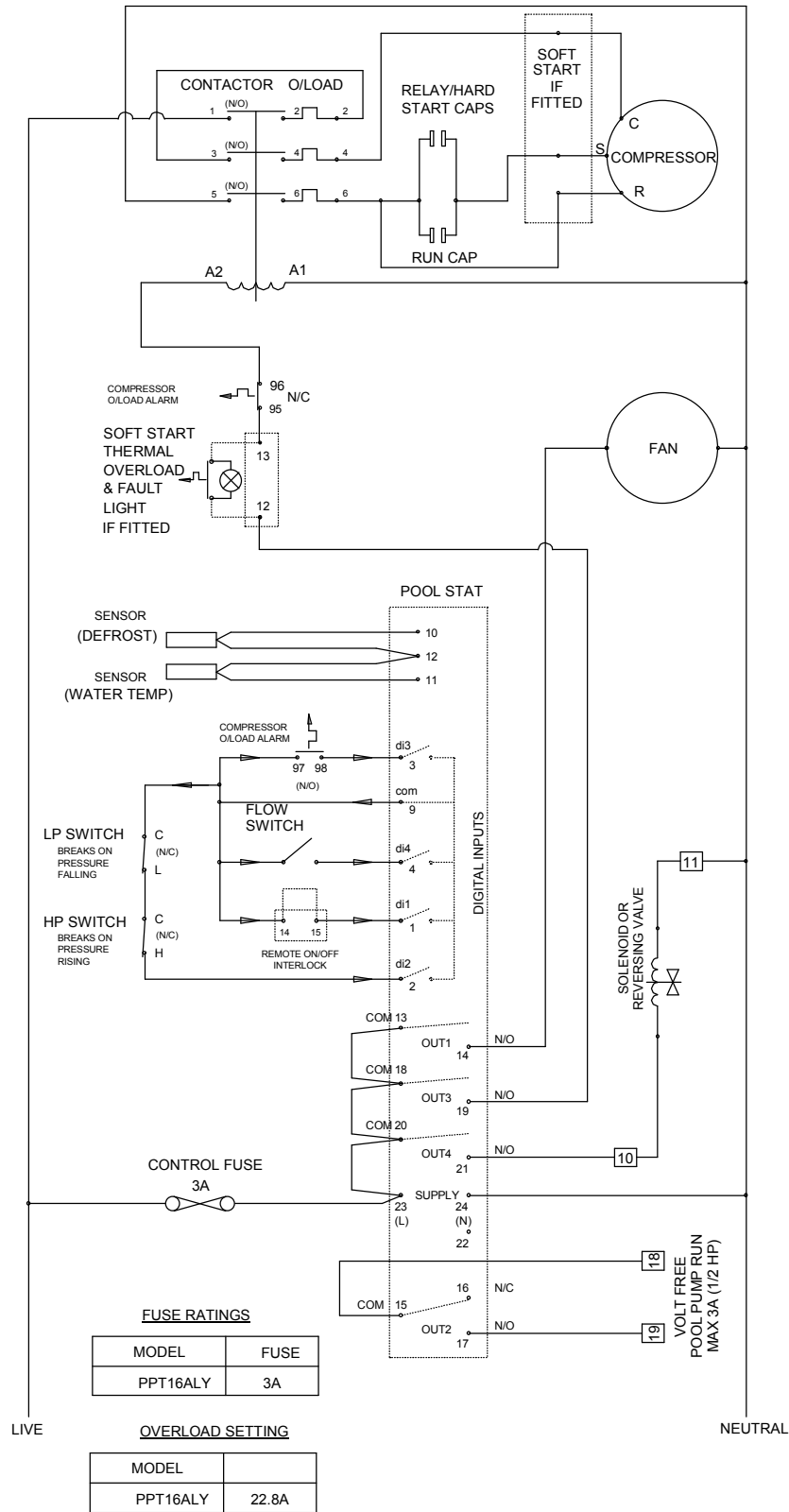

Installation Manual

PPT8/12/16/22LX/LY SLIMLINE



PPT22 ALY SINGLE PHASE 230V~1N 50Hz

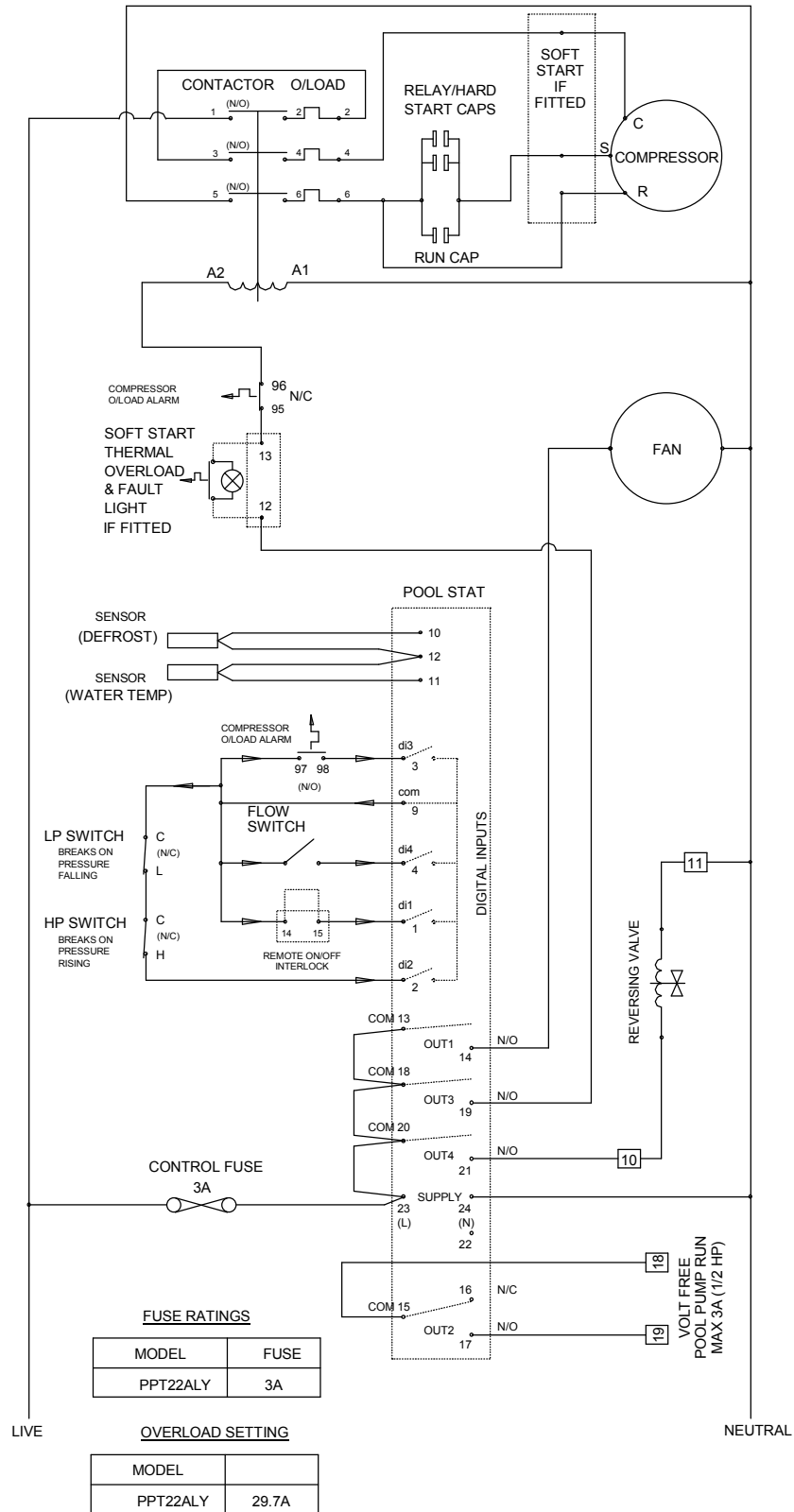

7.0 Regular planned maintenance

Operations to be carried out during a regular planned maintenance visit are as follows:

- 1) Clean the evaporator. (This action may be required more frequently than regular servicing).
- 2) Check operation of fan and compressor.
- 3) Check capacitor tolerances - where fitted.
- 4) Check condition of all heat exchangers/evaporators.
- 5) Check refrigeration system parameters.
- 6) Check operation of control valves.
- 7) Check for water leaks.
- 8) Check driptray and internal drain lines for blockages and flush through if necessary.
- 9) Check operation of controls and calibrate if necessary.
- 10) Check operation of interlocks in use.
- 11) Final check of overall operation of unit
- 12) Indicate on Service report any faults found or causes for concern.
- 13) Recommended servicing frequency: one visit per year.

7.1 Removal of service panels

Removal of the service panels is done in the following way.

- 1) Undo the screws at the end of the ABS cover. Lift and slide the cover back so that the bracket exits the slots at the opposite end of the unit.
- 2) The spreader bar across the width of the heat pump is secured with screws through the top of the evaporator and fan panels. To remove either of these panels the spreader bar needs to be unscrewed.
- 3) Remove the screws securing the panel along the bottom of the panel.
- 4) The panel can now be lifted upwards off spacers which retain the panel in keyhole slots.

IMPORTANT: The electric box is also supported by the spreader bar so it will either have to be removed or rested on top of the heat pump.

- 5) If access to the electric box is required see section 4.2 for instructions.

Installation Manual

PPT8/12/16/22LX/LY SLIMLINE



8.0 Heat Pump Malfunction

WARNING: Isolate heat pump electrically before entering heat pump or removing panels.

The user check list should be carried out before initiating a service call. Do not attempt to interfere with any internal control settings as these have been factory calibrated and sealed.

Any sign of abnormal operation such as water dripping should be reported immediately to the installer.

If in doubt or if advice is required contact Calorex Service Department. Telephone +44(0)1621 857171 or 856611

8.1 User Check List

The thermostat displays the following lamps during normal operation

SYMBOL	DESCRIPTION	LAMP ON	LAMP FLASHING	LAMP OFF
	DEFROST	HEAT PUMP IN DEFROST	-	-
	WATER HEATING	DEMAND FOR WATER HEATING	WATER HEATING DEMAND COMPRESSOR DELAY TIMER NOT TIMED OUT	NO DEMAND FOR WATER HEATING/ DEMAND SATISFIED
	FAN	FAN RUNNING	FAN NOT RUNNING COMPRESSOR DELAY TIMER NOT TIMED OUT	FAN NOT RUNNING
AUX	POOL PUMP	POOL PUMP RUNNING	-	POOL PUMP NOT RUNNING
OFF	OFF LAMP	HEAT PUMP OFF	-	-

If an error occurs any of the following lamps or messages will be displayed.

SYMBOL	DESCRIPTION	LAMP ON	LAMP FLASHING	ACTION
	ALARM - FAULT	ILLUMINATES WITH "to"	-	-
noF	WATER FLOW LAMP	WATER FLOW OFF OR INADEQUATE	WATER FLOW OFF OR INADEQUATE	CHECK WATER PUMP RUNNING AND ANY EXTERNAL BYPASS VALVES ARE CLOSED
to	THERMAL OVERLOAD (PPT16/22)	INTERNAL OVERLOAD TRIP	-	CONTACT COMPETENT ELECTRICIAN TO RESET THERMAL OVERLOAD. IF PROBLEM PERSISTS CHECK SITE VOLTAGE
PrA	PRESSURE SWITCH ALARM	HP/LP FAULT	-	CONSULT INSTALLER

SYMBOL	DESCRIPTION	LAMP ON	ACTION
E1-E1/ E2-E2	PROBE ERROR	PROBE INTERRUPTED, SHORT CIRCUIT OR OUTSIDE RANGE	CHECK CONNECTION BETWEEN PROBES AND THERMOSTAT
EPr	PROBE ERROR	INTERNAL EEPROM MEMORY ERROR	SWITCH OFF HEAT PUMP AT MAINS SUPPLY FOR FIVE MINUTES THEN SWITCH BACK ON. IF FAULT PERSISTS CONTACT INSTALLER

If the thermostat appears to be dead or reading incorrectly check that the connectors in the back of the digital thermostat are not loose. See section 5.1 for how to do this.

Installation Manual

PPT8/12/16/22LX/LY SLIMLINE



9.0 Datasheets

HEAT PUMPS FOR OUTDOOR POOLS SUMMER SEASON (ALX/BLX)

MODEL	Units	PPT8	PPT12	PPT16	PPT22
HEAT TO POOL WATER					
AMBIENT 10°C, WATER 24°C	kWh	7.2	9.9	12.4	17.7
AMBIENT 20°C, WATER 24°C	kWh	9.2	12.5	15.6	22.4
ELECTRICITY					
ELECTRICAL SUPPLY 1 PHASE		230V/~1N/ 50Hz			
ELECTRICAL SUPPLY 3 PHASE		400V/~3N/ 50Hz			
TOTAL POWER CONSUMED					
AMBIENT 10°C, WATER 24°C	kWh	1.8	2.3	2.6	4.1
AMBIENT 20°C, WATER 24°C	kWh	2.0	2.5	2.8	4.3
MIN SUPPLY CAPACITY (Max F.L.A.) 1 ph N:-	A	14.0	17.0	19.8	31.0
MIN SUPPLY CAPACITY (Max F.L.A.) 3 ph N:-	A	6.0	6.4	8.0	13.0
RECOMMENDED SUPPLY FUSE 1 ph N:-	A	20.0	25.0	30.0	42.0
RECOMMENDED SUPPLY FUSE 3 ph N:-	A	10.0	10.0	15.0	20.0
WATER FLOWS ETC					
POOL WATER FLOW RATE:-	L/min	75	75	125	167
POOL WATER PRESSURE DROP (@ Rated Flow):-	m hd	0.1	0.1	0.1	0.6
MAX WORKING PRESSURE POOL WATER:-	bar	2.5	2.5	3.5	3.5
POOL WATER CONNECTIONS:-	inches	1 1/2" or 50mm Female			
CONDENSATE DRAIN CONNECTIONS:-	inches	3/4" DOMESTIC WASTE			
COMPRESSOR					
NOMINAL POWER CONSUMED	kWh	1.6	2.35	2.6	3.8
L.R.A. 1 ph N:-	A	62	62	103	136
R.L.A. 1 ph N:-	A	11.5	13.1	15.8	25
SOFT START AMPS 1 ph N:-	A	28	28	34	37
L.R.A. 3 ph N:-	A	32	30	48	48
R.L.A. 3 ph N:-	A	4	4.7	7.3	10
SOFT START AMPS 3 ph N:-	A	14	14	25	25
MAIN FAN					
AIR FLOW (Anemometer @ air on grille. Dry evaporator):-	m³/h	2200	3300	3500	4100
F.L.A. 1 ph N:-	A	0.82	0.82	0.82	0.82
GENERAL DATA					
HERMETIC SYSTEM					
GAS CHARGE R407c	kg	1.9	2.5	5.0	6.0
SOUND PRESSURE LEVEL @3m AIR ON	dbA	53	54	53	54
SOUND PRESSURE LEVEL @3m AIR OFF	dbA	57	55	55	56
SOUND PRESSURE LEVEL @3m SIDE	dbA	50	47	48	52
SOUND POWER	dbA	69.9	67.3	68.2	67.8
*PHYSICAL DIMENSIONS					
*WIDTH (Unpacked):-	mm	1237	1237	1237	1237
*DEPTH (Unpacked):-	mm	535	535	535	535
*HEIGHT (Unpacked):-	mm	725	725	725	904
WEIGHT (Unpacked):- ALX	kg	91	96	113	119
WEIGHT (Unpacked):- BLX	kg	-	96	118	119
WEIGHT (Packed):- ALX	kg	110	119	142	143
WEIGHT (Packed):- BLX	kg	110	119	140	143

FOR ACCURATE APPLICATION SIZING CONSULT CALOREX HEAT PUMPS LTD

NOTES

- 1) Weight and dimensions nett. * DIMENSIONS EXCLUDE WATER IN/OUT STUBS AND MAINS IN CABLE GLAND.
- 2) Performance design limitations: Ambient = 5°C min 40°C max, Water = 10°C min, 40°C max.
- 3) Pool water to have correct balance, pH 7.2-7.8, Free Chlorine 1.0 - 2.0ppm domestic, 3.0 - 6.0 commercial.
- 4) Allow 500mm clearance to service panels.
- 5) Calorex reserve the right to change or modify models without prior notice.
- 6) R407c Global warming potential (GWP) 1774.
1mm WG = 9.8 Pa
1mhd = 1.4 psi
1l/min = 0.22gall/min

Installation Manual

PPT8/12/16/22LX/LY SLIMLINE



9.0 Datasheets

HEAT PUMPS FOR OUTDOOR POOLS REVERSE CYCLE DEFROST (ALY/BLY)

MODEL	Units	PPT8	PPT12	PPT16	PPT22
HEAT TO POOL WATER					
AMBIENT 0°C WATER 24°C	kWh	5.2	7.2	9.0	10.7
AMBIENT 10°C, WATER 24°C	kWh	7.2	9.9	12.4	17.7
AMBIENT 20°C, WATER 24°C	kWh	9.20	12.5	15.6	22.4
ELECTRICITY					
ELECTRICAL SUPPLY 1 PHASE		230V/~1N/ 50Hz			
ELECTRICAL SUPPLY 3 PHASE		400V/~3N/ 50Hz			
TOTAL POWER CONSUMED					
AMBIENT 0°C WATER 24°C	kWh	1.7	2.2	2.5	3.8
AMBIENT 10°C, WATER 24°C	kWh	1.8	2.3	2.6	4.1
AMBIENT 20°C, WATER 24°C	kWh	2.0	2.5	2.8	4.3
MIN SUPPLY CAPACITY (Max F.L.A.) 1 ph N:-	A	14.0	17.0	19.8	31.0
MIN SUPPLY CAPACITY (Max F.L.A.) 3 ph N:-	A	6.0	6.4	8.0	13.0
RECOMMENDED SUPPLY FUSE 1 ph N:-	A	20.0	25.0	30.0	42.0
RECOMMENDED SUPPLY FUSE 3 ph N:-	A	10.0	10.0	15.0	20.0
WATER FLOWS ETC					
POOL WATER FLOW RATE:-	L/min	75	75	125	167
POOL WATER PRESSURE DROP (@ Rated Flow):-	m hd	0.1	0.1	0.1	0.6
MAX WORKING PRESSURE POOL WATER:-	bar	2.5	2.5	3.5	3.5
POOL WATER CONNECTIONS:-	inches	1 1/2" or 50mm Female			
CONDENSATE DRAIN CONNECTIONS:-	inches	3/4" DOMESTIC WASTE			
COMPRESSOR					
NOMINAL POWER CONSUMED	kWh	1.6	2.35	2.6	3.2
L.R.A. 1 ph N:-	A	62	62	103	136
R.L.A. 1 ph N:-	A	11.5	13.1	15.8	25
SOFT START AMPS 1 ph N:-	A	28	28	34	37
L.R.A. 3 ph N:-	A	32	30	48	48
R.L.A. 3 ph N:-	A	4	4.7	7.3	10
SOFT START AMPS 3 ph N:-	A	14	14	25	25
MAIN FAN					
AIR FLOW (Anemometer @ air on grille. Dry evaporator):-	m³/h	2200	3300	3500	4100
F.L.A. 1 ph N:-	A	0.82	0.82	0.82	0.82
GENERAL DATA					
HERMETIC SYSTEM					
GAS CHARGE R407c	kg	1.9	2.7	5.9	6.7
SOUND PRESSURE LEVEL @3m AIR ON	dbA	53	54	53	54
SOUND PRESSURE LEVEL @3m AIR OFF	dbA	57	55	55	56
SOUND PRESSURE LEVEL @3m SIDE	dbA	50	47	48	52
SOUND POWER	dbA	69.9	67.3	68.2	67.8
*PHYSICAL DIMENSIONS					
*WIDTH (Unpacked):-	mm	1237	1237	1237	1237
*DEPTH (Unpacked):-	mm	535	535	535	535
*HEIGHT (Unpacked):-	mm	725	725	725	904
WEIGHT (Unpacked):- ALY	kg	96	104.4	130.5	141
WEIGHT (Unpacked):- BLY	kg	-	111.6	N/A	137.6
WEIGHT (Packed):- ALY	kg	115	127.4	159.5	162
WEIGHT (Packed):- BLY	kg	-	134.6	N/A	158.6

FOR ACCURATE APPLICATION SIZING CONSULT CALOREX HEAT PUMPS LTD

Installation Manual

PPT8/12/16/22LX/LY SLIMLINE



10.0 Installation Drawings

PPT8
 WATER IN/OUT 1 1/2" or 50mm FEMALE
 CONDENSATE 3/4" DOMESTIC WASTE

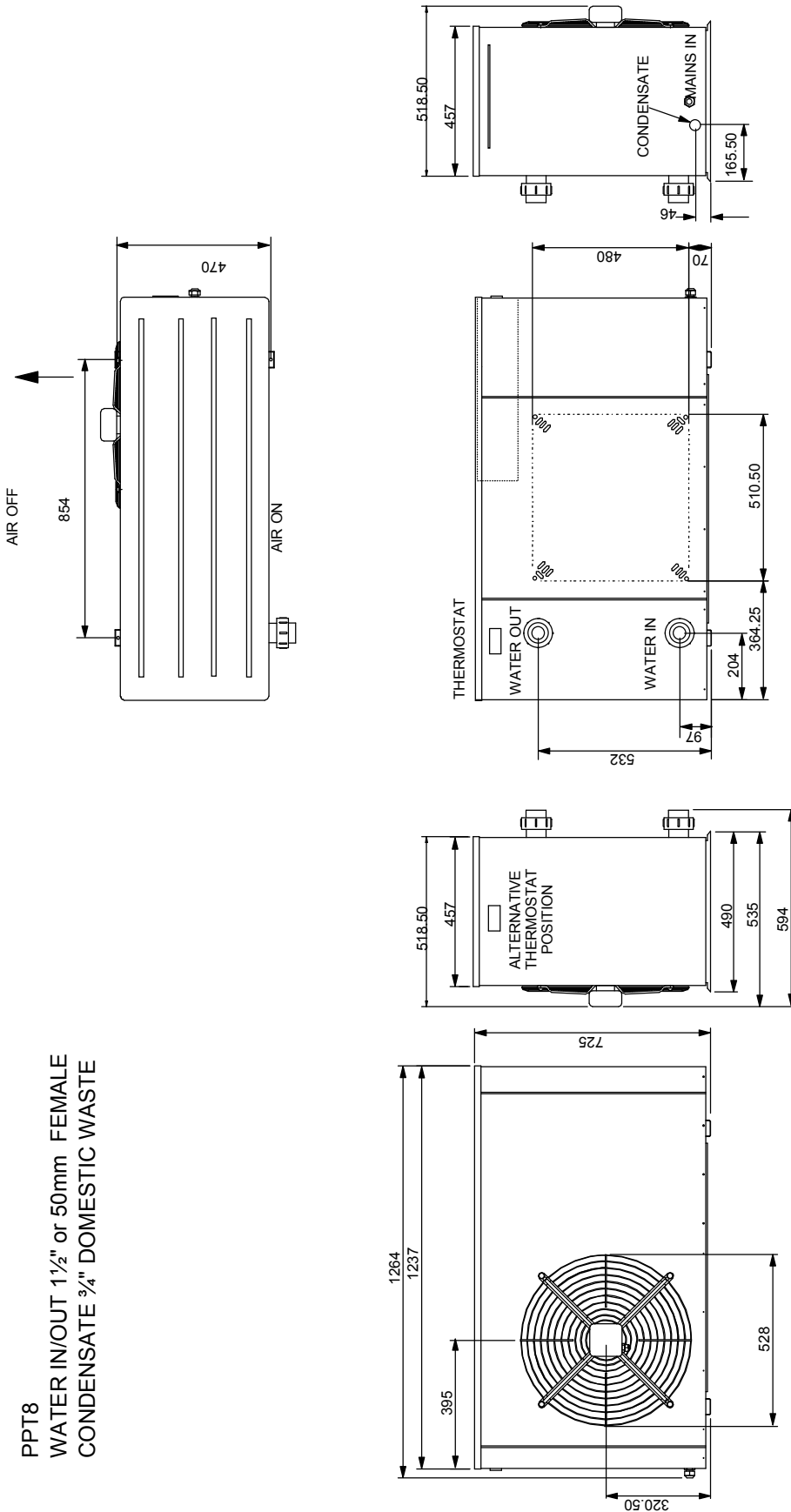

Installation Manual

PPT8/12/16/22LX/LY SLIMLINE

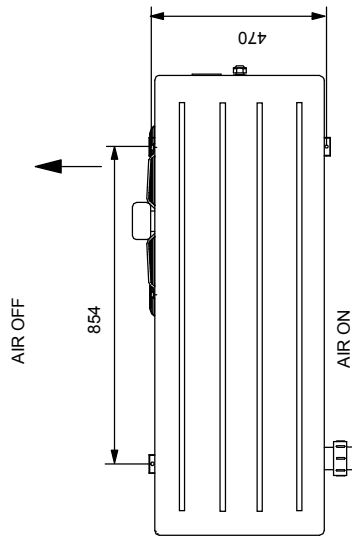

PPT12
 WATER IN/OUT 1 1/2" or 50mm Female
 CONDENSATE 3/4" DOMESTIC WASTE

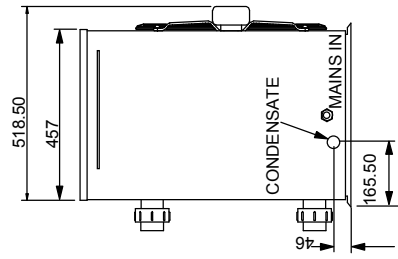
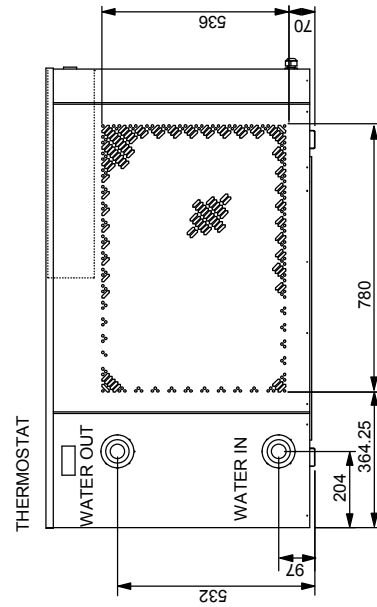
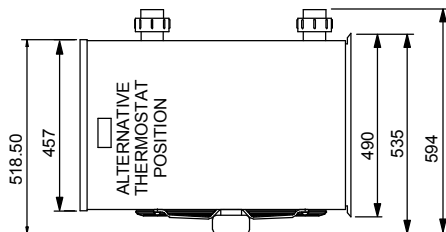
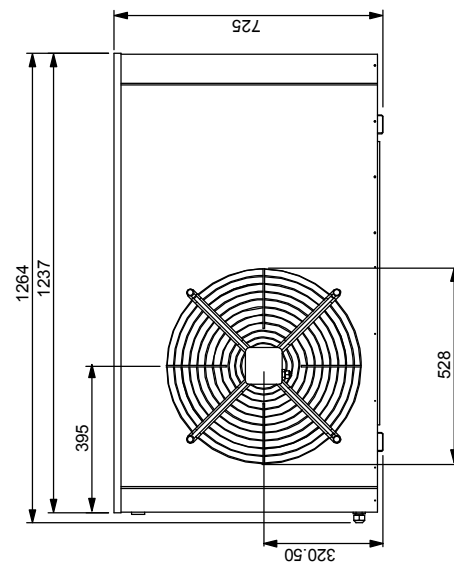

Installation Manual

PPT8/12/16/22LX/LY SLIMLINE

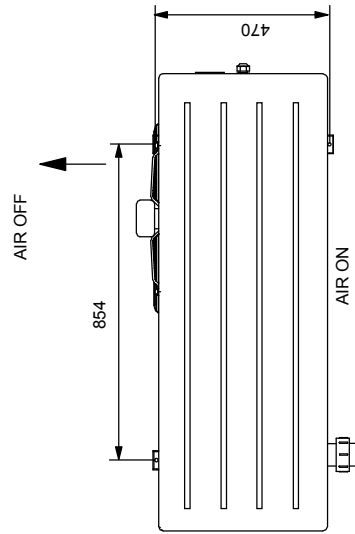

PPT16
 WATER IN/OUT 1 1/2" or 50mm Female
 CONDENSATE 3/4" DOMESTIC WASTE

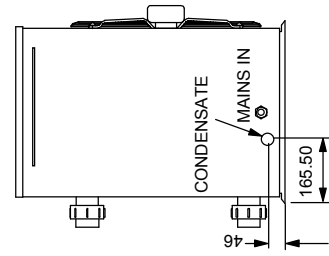
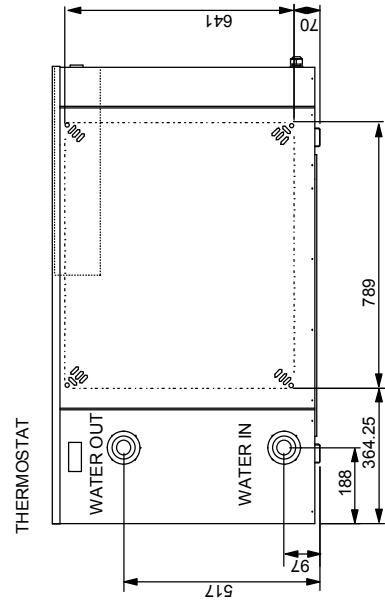
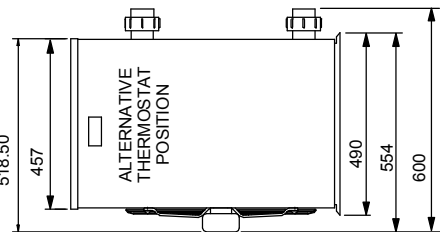
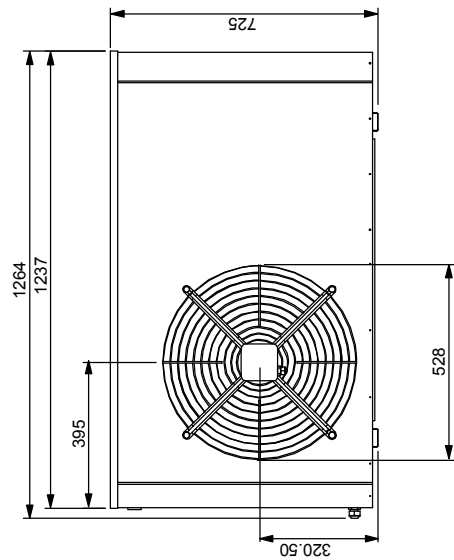

Installation Manual

PPT8/12/16/22LX/LY SLIMLINE



PPT22
 WATER IN/OUT 1½" or 50mm FEMALE
 CONDENSATE ¾" DOMESTIC WASTE

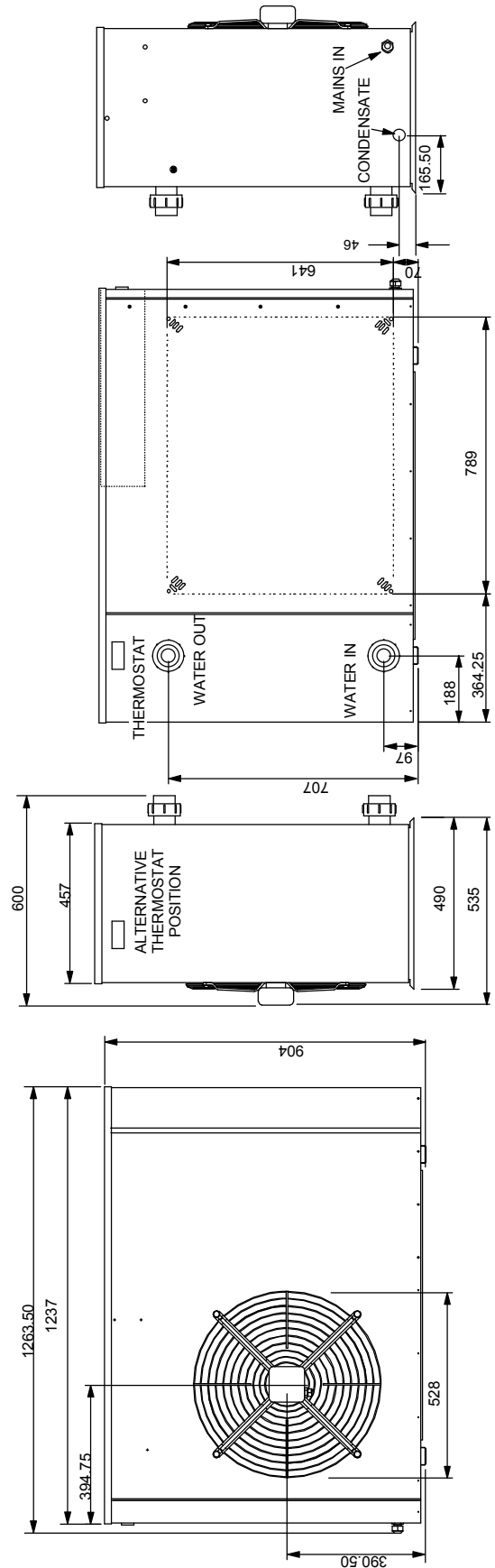
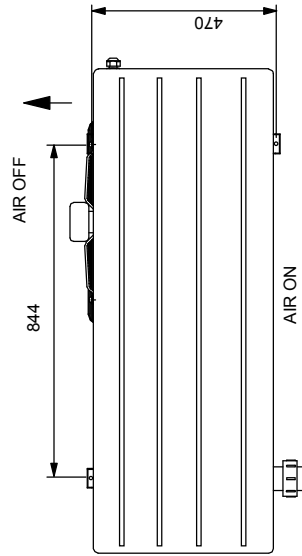

11.0 Winterisation
Procedure

**WARNING. Isolate machine before removing covers!
The heat pump embodies electrical and rotational
equipment, it is recommended for your own safety
that a competent person carries out the following
procedure**

ALL MODELS

Objective

To provide frost protection

To eliminate corrosion problems

To inhibit electrical components

- 1) Switch off electric supply to heat pump.
- 2) Remove external fuses and keep in safe place away from heat pump to prevent accidental operation of heat pump.
- 3) Ensure water circulation pump is switched off.
- 4) Drain water from heat pump by:
 - a) drain valve if fitted
 - b) disconnecting pipework to and from heat pump
- 5) Flush through water circuit in heat pump by using CLEAN TAP WATER (NOT POOL WATER) via hose into outlet connection - run the hose for 10 minutes minimum; use spray nozzle if available.
- 6) Allow to drain - when drained, fit plastic bags secured by elastic bands over water connections.
- 7) Uncover electrical enclosure (see section 4.2) and liberally spray interior of unit, with moisture-repellant aerosol WD40 or similar; reseal enclosure.
- 8) If heat pump located outside, protect from weather by covering with VENTILATED cover. Do not use plastic sheet as condensation could occur within unit.

IMPORTANT

If this procedure is not adopted and frost or corrosion damage results then the warranty will become invalid.



11.1 Start up Procedure After Winterisation

- 1) Replace covers (if not fitted).
- 2) Remove front grille. Using a soft brush clean finned surfaces of heat pump. Replace panel.
- 3) Remove plastic covers on water connections and reconnect water piping or close drain valve.
- 4) Start up water circulating pump and leave running for at least 1/4 hour to establish flow and enable an air in piping to escape.
- 5) Replace fuses to heat pump circuit.
- 6) Switch on heat pump.
- 7) Check control thermostat is set to required pool temperature.
- 8) Check pool water daily to ensure it is at correct pH and has correct chemical balance. (See Section 3 Plumbing).

Installation Manual

PPT8/12/16/22LX/LY SLIMLINE



12.0 Warranty Conditions

The following exclusions apply to the Warranty given by Calorex Heat Pumps Ltd. No claims will be accepted if : -

- 1) The heat pump is incorrectly sized for the application.
- 2) The heat pump is installed in any way that is not in accordance with the current procedures as defined by Calorex Heat Pumps Ltd.
- 3) The heat pump has been worked upon or is adjusted by anyone other than a person authorised to do so by Calorex Heat Pumps Ltd.
- 4) The air flow to and from the machine is outside the specified limits.
- 5) The water flow through the machine is outside the specified limits.
- 6) The water pH level and/or chemical balance is outside the following limits:-

Acidity pH	pH	7.2 - 7.8
Total Alkalinity, as CaCO ₃	ppm	80 - 120
Total Hardness, as CaCO ₃	ppm	150 - 250
Total Dissolved Solids	ppm	1000 Max
Maximum Salt Content	ppm	35000 Max
Free Chlorine Range	ppm	1 - 2 Domestic
Free Chlorine Range	ppm	3 - 6 Commercial
Superchlorination	max	30ppm for 24 hrs
Bromine	ppm	2 - 5
Baquacil	ppm	25 - 50
Ozone	ppm	0.9 Max
Maximum Copper Content	ppm	1
Aquamatic Ionic Purifier	ppm	2 Max

- 7) The heat pump has suffered frost damage.
- 8) The electrical supply is insufficient or in any way incorrect.

Installation Manual

PPT8/12/16/22LX/LY SLIMLINE



13.0. Contacting Calorex

Email: service@calorex.com

Website: www.calorex.com

Tel: +44 (0)1621 857171 or +44 (0)1621 856611

Please give MODEL NUMBER and SERIAL NUMBER of your heat pump when making technical or service enquiries. This will assist in correct diagnosis and ensure service can be provided with the minimum delay.

Installation Manual

PPT8/12/16/22LX/LY SLIMLINE



14.0 Machine Record Log

In order to comply with European Union F-Gas regulations, it is necessary to leak test hermetically sealed systems with more than 6kg refrigerant annually.

The operator of the unit is responsible for seeing that the test is carried out.

For machines affected see datasheet section 9.0. A sample log sheet can be seen below.

Calorex is an FGAS registered company. Certificate number REF1011570

General Information				
Plant Name				Serial Number
Location of Plant				
Plant Operator ¹				
Operator Contact ²				
Refrigerant Type				Refrigerant Quantity installed (kg)
Plant manufacturer	Calorex Heat Pumps Limited			Year of installation
Refrigerant Additions				
Date	Engineer ³		Amount Added kg	Reason for addition
	Company	Name		
Refrigerant Removals				
Date	Engineer		Amount Removed kg	Reason for removal What done with recovered refrigerant
	Company	Name		
Name and Address of Recycling or reclamation facility				Certificate number if applicable
Leak Tests				
Date	Engineer		Test Result	Follow up action required
	Company	Name		
Follow up Actions				
Date	Engineer		Related to test on	Actions taken
	Company	Name		
Testing of Automatic Leak Detection System (if fitted)				
Date	Engineer		Test Result	Comments
	Company	Name		

¹ Name and address of company operating plant.

² Contact details for operator's nominated person responsible for F Gas compliance.

³ Company and technician carrying out work, with details to provide evidence of compliance.

IMPORTANT : The company carrying out refrigerant checking and removals, and the owner of the equipment need to keep records for FIVE YEARS

When this machine is decommissioned the refrigerant gas is to be recovered in accordance with the current environmental legislation.